

radicon



with you at every turn

benzlers



with you at every turn

Series K Helical Bevel

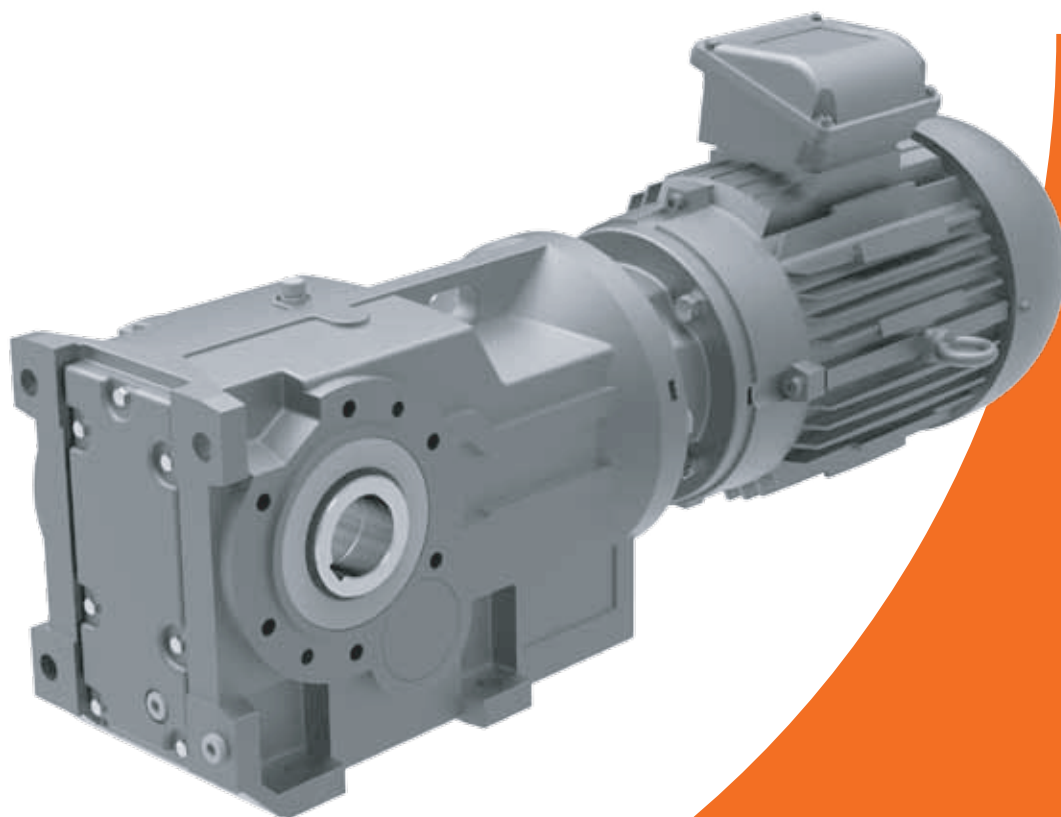

Technical
Up to - 90 kW / 12,300 Nm

Geared Motors
CK-2.00GB 1211

ATEX Compliance Assured



Total compliance with the ATEX Directive safeguarding the use of industrial equipment in potentially explosive atmospheres is assured for users of our geared products.

Certification is available for standard gearboxes and geared motors with badging displaying the ATEX zone, name and location of the manufacturer, designation of series or type, serial number, year of manufacture, Ex symbol and equipment group/category.

ATEX directive 94/9/EC (also known as ATEX 95 or ATEX 100A) enforced in all EC member states. Compliance is compulsory for designers, manufacturers or suppliers of electrical and non-electrical equipment for use in potentially explosive atmospheres created by the presence of flammable gases, vapours, mists or dusts.

Ex compliant standard gearboxes can be supplied against Groups 2 or 3 for surface industries in designated hazardous location Zones 1 and 2 for gases, vapours and mists; and in Zones 21 and 22 for dusts.

General Description _____	1
Unit Designations _____	2
Explanation and use of Ratings and Service Factors _____	3
Load Classification by Applications _____	4
Selection Procedure For Motorised Units _____	5 - 6
Output Options _____	7 - 8
Motor Adaptors _____	9 - 10
Lubrication _____	11
Mounting Positions _____	12
Unit Handings _____	13
MOTORISED	
Motor Performance Data and Standard Motor Variants Available _____	16
Motor Details _____	17
Additional Motor Features _____	18
Additional Gearbox Features _____	19
Exact Ratios _____	20 - 21
Selection Tables Geared Motors _____	22 - 53
Dimension Sheets - Geared Motors _____	54 - 56
Motorised Backstop Module _____	57
REDUCER	
Overhung & Axial Loads on Shafts _____	60
Thermal Power Ratings _____	61
Ratings - Input Power / Output Torque _____	62 - 71
Dimension Sheets - Speed Reducers _____	72 - 73
Fan Cooled Units _____	74
Reducer Backstop Module _____	75
OUTPUT OPTIONS	
Dimensions of Outputshaft Options _____	76
Shrink Disc _____	77
Dimension Sheet - Torque Bracket _____	78
Dimensions of B5 (D) Flange units _____	79
Dimensions of B14 (C) Flange units _____	80
Dimensions Sheet - Assembly / Disassembly _____	81 - 82
Shipping Specification _____	83

SERIES K

GENERAL DESCRIPTION

Series K

Series K right angle drive helical bevel helical geared motors offer ratios from 8 : 1 to 160 : 1 in three stages or up to 10,000 : 1 in five stages and 36,000 : 1 in 6 stages. Motors are available up to 90kW and output torque capacity up to 12,300Nm. The Series K geared motor is designed with integral cast feet for base or end mounting and can be offered with single or double extended output shafts. Units are also available shaft mounted or with output flanges and are available for mounting horizontally or vertically. The units can also be offered with a bolt on torque reaction bracket and all variants are available either motorised or with an input shaft assembly.

Adding to the range of geared motors this product takes advantage of our many years of accumulated design expertise together with the use of high quality materials and components. The end result is a series of speed reducing geared motors offering high load carrying capacities, increased efficiency, quiet running and reliability.

The range includes:

9 sizes of unit
K03, K04, K05, K06, K07, K08, K09, K10 and K12.

- Version B - standard unit with feet
- Version F or H - standard unit with output flange
- Version T or Q - standard unit with torque bracket

Unit Types:

- Unit type M - Motorised with IEC standard motor
- Unit type N - Motorised with NEMA standard motor
- Unit type H - Motorised with high efficiency motor (IE2 or EPACT)
- Unit type E - Motorised with NEMA high efficiency motor (EPACT)
- Unit type G - Unit to allow fitting of IEC motor
- Unit type A - Unit to allow fitting of NEMA motor
- Unit type R - Reducer unit
- Unit type S - Reducer unit with fan kit
- Unit type W - Reducer unit with backstop CCW rotation
- Unit type X - Reducer unit with backstop CW rotation
- Unit type Y - Reducer unit with fan and backstop CW rotation
- Unit type Z - Reducer unit with fan and backstop CCW rotation

Design Features Include:

- Patented standard motor connection (IEC or NEMA)
- Ability to fit double oil seals, on output shaft or reducer input shaft as required.
- All units are dimensionally interchangeable with other major European manufacturers
- Braked geared motors are available as standard
- Units are manufactured and assembled from a family of modular kits for distributor friendliness minimising inventory and maximising availability
- Motorised units can be fitted with a backstop module and reducer units can be fitted with a backstop and fan.

As improvements in design are being made continually this specification is not to be regarded as binding in detail and drawings and capacities are subject to alteration without notice. Certified drawings will be sent on request.

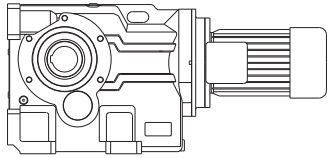

Motorised
Triple reduction
Standard unit with feet

*

K	0	8	3	2	5	0	.	B	M	C	-	1	B	7	.	5	A	-	-
---	---	---	---	---	---	---	---	---	---	---	---	---	---	---	---	---	---	---	---

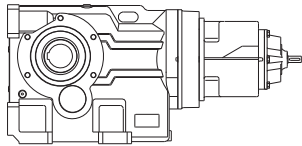

Reducer
Quintuple reduction
Standard unit with feet

*

K	0	8	5	2	1	2	C	B	R	C	-	1	-	-	-	-	-	-	-
---	---	---	---	---	---	---	---	---	---	---	---	---	---	---	---	---	---	---	---

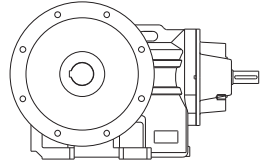

Reducer
Triple reduction
Standard unit with output flange on left

*

K	0	9	3	1	5	0	.	F	R	H	-	1	-	-	-	-	-	-	-
---	---	---	---	---	---	---	---	---	---	---	---	---	---	---	---	---	---	---	---

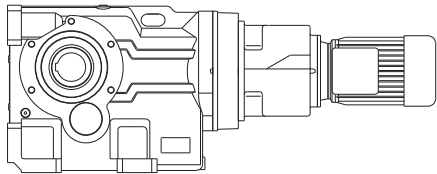

Motorised
Quintuple reduction
Standard unit with feet

*

K	0	8	5	2	1	2	C	B	M	C	-	1	B	.	2	5	A	-	-
---	---	---	---	---	---	---	---	---	---	---	---	---	---	---	---	---	---	---	---

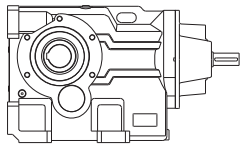

Reducer
Triple reduction
Standard unit with feet

*

K	0	8	3	2	5	0	.	B	R	C	-	1	-	-	-	-	-	-	-
---	---	---	---	---	---	---	---	---	---	---	---	---	---	---	---	---	---	---	---

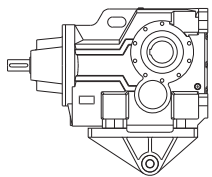

Reducer
Triple reduction
Standard unit with torque bracket

*

K	0	8	3	2	5	0	.	T	R	H	-	1	-	-	-	-	-	-	-
---	---	---	---	---	---	---	---	---	---	---	---	---	---	---	---	---	---	---	---

* Typical unit designations

SERIES K

UNIT DESIGNATIONS

Gearbox Codes													Motor Codes							
Series	Size of Unit		No of Reductions	Revision Version	Nominal Overall Ratio			Unit Version	Type of Unit	Output Shaft	Motor Adaptor	Mounting Position	Geared Motor Power			No of Motor Poles	Additional Motor Features	Additional Gearbox Features		
1	2	3	4	5	6	7	8	9	10	11	12	13	14	15	16	17	18	19	20	
K																				
Example	K	0	8	3	2	5	0	.	B	M	C	G	1	D	4	-	0	A	-	-

** Looking on Inputshaft Mounting Position 1 (See unit handings page)
 *** Non Standard and Handing - Consult Application Engineering

20 - Additional Gearbox Features
 Double Oil Seal, Motorised Backstop etc

e.g. F

19 - Additional Motor Features

e.g. A

For Types Without Motor Enter

18 - No of Motor Poles

No motor

		50 Hz		60 Hz
4 Pole (Std) 1500 rpm	<input type="checkbox"/> A	1800 rpm	<input type="checkbox"/> B	
4 Pole (High) 1500 rpm	<input type="checkbox"/> K	1800 rpm	<input type="checkbox"/> L	
6 Pole (Std) 1000 rpm	<input type="checkbox"/> C	1200 rpm	<input type="checkbox"/> D	
6 Pole (High) 1000 rpm	<input type="checkbox"/> M	1200 rpm	<input type="checkbox"/> N	
2 Pole 3000 rpm	<input type="checkbox"/> E	3600 rpm	<input type="checkbox"/> F	
8 Pole 750 rpm	<input type="checkbox"/> G	900 rpm	<input type="checkbox"/> H	

S Dual speed or special motor

15, 16, 17 - Geared Motor Powers

Motor Power Required

e.g. 7 5

For reducer and non standard

motor types enter

13, 14 - Mounting Position

e.g. 2 B

12 - Motor Adaptor For Unit Types Column 10 Entries M, N, H, E, G or A

For All Other Types Enter

11 - OUTPUT SHAFT

Standard Single Extension C on Left ** E on Right **

Standard Double Extension D

Standard Hollow Shaft H

Standard Shrink Disc Y on Right** X on Left ***

1 - Series K

Range K

2, 3 - Size of Unit

0 3 Through 1 2

4 - No of Reductions

3 Through 5

5 - Revision Version

2 For Sizes 03 to 08
 1 For Sizes 09 to 12

6, 7, 8 - Nominal Overall Ratio

e.g. 5 0 .

9 - Unit Version

Standard Unit with Feet B

STD Unit with Output Flange F on Left ** H on Right **

STD Unit with Torque Bracket T on Left ** Q on Right **

10 - Type of Unit

- M - Motorised with IEC standard motor (IE2)
- N - Motorised with NEMA standard motor (EPACT)
- H - Motorised with IEC high efficiency motor (IE2 or EPACT)
- E - Motorised with NEMA high efficiency motor (PREMIUM)
- G - Unit to allow fitting of IEC motor (customer own motor)
- A - Unit to allow fitting of NEMA motor (customer own motor)
- R - Reducer unit
- S - Reducer unit with fan kit
- W - Reducer unit with backstop CCW rotation
- X - Reducer unit with backstop CW rotation
- Y - Reducer unit with fan and backstop CW rotation
- Z - Reducer unit with fan and backstop CCW rotation

* This Page May Be Photocopied Allowing The Customer To Enter Their Order
 To access the on line configurator please visit www.swift-gears.com

SERIES K

EXPLANATION & USE OF RATINGS & SERVICE FACTORS

Gear unit selection is made by comparing actual loads with catalogue ratings. Catalogue ratings are based on a standard set of loading conditions, whereas actual load conditions vary according to type of application. Service Factors are therefore used to calculate an equivalent load to compare with catalogue ratings.

i.e. Equivalent Load = Actual Load x Service Factor

Mechanical ratings and service factors Fm and Fs

Mechanical ratings measure capacity in terms of life and/or strength, assuming 10 hr/day continuous running under uniform load conditions.

Catalogue ratings allow 100% overload at starting, braking or momentarily during operation up to 10 hours per day.

The unit selected must therefore have a catalogue rating at least equal to half maximum overload.

Mechanical Service Factor Fm (Table 1) is used to modify the actual load according to daily operating time, and type of loading.

Load characteristics for a wide range of applications are detailed in Table 3 opposite, which are used in deciding the appropriate Service Factor Fm from Table 1.

If overloads can be calculated, or accurately assessed, actual loads should be used instead of Fm.

For units subjected to frequent stop/starts overloads in excess of 10 times/day multiply factor Fm x Factor Fs (table 2).

For applications where units are to operate in extremely dusty or moist/humid atmospheres unit selection should be referred to application engineering.

Table 1. Mechanical Service Factor (Fm)

Prime mover	Duration of service- hrs per day	Load classification-driven machine		
		Uniform mass acceleration factor ≤ 0.2	Moderate mass acceleration factor ≤ 3	Heavy mass acceleration factor ≤ 10
Electric motor, steam turbine or hydraulic motor	Under 3	0.80	1.00	1.50
	3 to 10	1.00	1.25	1.75
	Over 10	1.25	1.50	2.00
Multi-cylinder internal combustion engine	Under 3	1.00	1.25	1.75
	3 to 10	1.25	1.50	2.00
	Over 10	1.50	1.75	2.25
Single cylinder internal combustion engine	Under 3	1.25	1.50	2.00
	3 to 10	1.50	1.75	2.25
	Over 10	1.75	2.00	2.50

$$\text{Mass acceleration factor} = \frac{\text{all external moments of inertia}^*}{\text{moment of inertia of driving motor}}$$

* calculated with reference to the motor speed

Table 2. Number of Starts Factor (Fs)

Start / Stops per hour (1)	Up to 1	5	10	40	60	≥ 200
Factor Fs	1.00	1.03	1.06	1.10	1.15	1.20

Note: (1) Intermediate values are obtained by linear interpolation

SERIES K

SELECTION PROCEDURE FOR MOTORISED UNITS

EXAMPLE APPLICATION DETAILS

Absorbed power of driven machine = 13kW
 Output speed of gearbox or Input speed of machine = 44rev/min
 Application = Uniformly loaded belt conveyor
 Duration of service (hours per day) = 24hrs
 Mounting position = 1
 Ambient temperature = 20°C
 Running time (%) = 100%

1 DETERMINE MECHANICAL SERVICE FACTOR (Fm)

Refer to Load Classification by Application, table 3.

Application = Uniformly loaded belt conveyor

Conveyors-uniformly loaded or fed		U = Uniform load
apron	U	
assembly	U	
belt	U	
bucket	U	
chain	U	

Refer to mechanical service factor (Fm), table 1, page 3

Duration of service (hours per day) = 24hrs

Prime mover	Duration of service-hrs per day	Load classification-drive	
		Uniform	Moderate Shock
Electric motor, steam turbine or hydraulic motor	Under 3	0.80	1.00
	3 to 10	1.00	1.25
	Over 10	1.25	1.50

Therefore mechanical service factor (Fm) = 1.25

2 DETERMINE REQUIRED OUTPUT TORQUE AT GEARBOX OUTPUTSHAFT

$$\text{Absorbed output torque} = \frac{\text{Absorbed power} \times 9550}{\text{Gearbox output speed}}$$

$$\frac{13 \times 9550}{43} = 2887 \text{ Nm}$$

3 SELECT GEARED MOTOR

Refer to selection table one motor size larger than absorbed power.

Absorbed power = 13kW, therefore refer to 15kW selection table.

Always select from 4 POLE selection table in the first instance as this offers a more economical solution.

Required output speed of gearbox = 43 rev/min

15 kW	N2 R/MIN	i	M2 Nm	Fm	N	UNIT DESIGNATION	Kg	Motor Frame Size
	Output Speed	Ratio	Output Torque	Service Factor	Overhung Load	Column Entry 1 Through 20 Spaces to be filled when entering order	Weight of Base Mount Unit	
4 POLE	181	8.03	757	3.39	34000	K 0 9 3 1 8 . 0 _ M _ _ _ 1 5 . A _ _	272	160L
	97	14.94	1408	2.68	34000	1 6 .		
	81	17.93	1700	2.05	34000	1 8 .		
	73	20.03	1893	1.88	34000	2 0 .		
	67	21.61	2040	2.03	34000	2 2 .		
	60	24.14	2280	1.85	34000	2 5 .		
	52	27.78	2621	1.44	34000	2 8 .		
	46	31.67	3005	1.26	34000	3 2 .		
	43	33.47	3162	1.33	34000	3 6 .		
	38	38.16	3596	1.17	34000	4 0 .		

Go to point 4

SERIES K

SELECTION PROCEDURE FOR MOTORISED UNITS

4 CHECK OUTPUT TORQUE

Output torque (M2) of selected unit must be equal or more than required output torque at gearbox outputshaft.

Required output torque at gearbox outputshaft = 2887 Nm

15 kW	N2 R/MIN	i	M2 Nm	Fm	N	UNIT DESIGNATION	Kg	Motor Frame Size
	Output Speed	Ratio	Output Torque	Service Factor	Overhung Load			
4 POLE	181	8.03	757	3.39	34000	K 0 9 3 1 8 . 0 _ M _ - _ - 1 5 . A - -	272	160L
	97	14.94	1408	2.68	34000	1 6 .		
	81	17.93	1700	2.05	34000	1 8 .		
	73	20.03	1893	1.88	34000	2 0 .		
	67	21.61	2040	2.03	34000	2 2 .		
	60	24.14	2280	1.85	34000	2 5 .		
	52	27.78	2621	1.44	34000	2 8 .		
	46	31.67	3005	1.26	34000	3 2 .		
	43	33.47	3162	1.33	34000	3 6 .		
	38	38.16	3596	1.17	34000	4 0 .		

Selected unit's output torque (M2) = 3162 Nm, therefore unit is acceptable

5 CHECK SERVICE FACTOR

Service factor (Fm) of selected unit must be equal or more than required service factor.

Required service factor of gearbox = 1.25

15 kW	N2 R/MIN	i	M2 Nm	Fm	N	UNIT DESIGNATION	Kg	Motor Frame Size
	Output Speed	Ratio	Output Torque	Service Factor	Overhung Load			
4 POLE	181	8.03	757	3.39	34000	K 0 9 3 1 8 . 0 _ M _ - _ - 1 5 . A - -	272	160L
	97	14.94	1408	2.68	34000	1 6 .		
	81	17.93	1700	2.05	34000	1 8 .		
	73	20.03	1893	1.88	34000	2 0 .		
	67	21.61	2040	2.03	34000	2 2 .		
	60	24.14	2280	1.85	34000	2 5 .		
	52	27.78	2621	1.44	34000	2 8 .		
	46	31.67	3005	1.26	34000	3 2 .		
	43	33.47	3162	1.33	34000	3 6 .		
	38	38.16	3596	1.17	34000	4 0 .		

Selected unit's service factor (Fm) = 1.33, therefore unit is acceptable.

6 CHECK OVERHUNG LOADS

If sprocket, gear, etc is mounted on the outputshaft then refer to Overhung Loads Procedure and compare with allowable overhung load (N) of selected unit

Allowable overhung load (N) must be equal or more than calculated overhung load (P)

15 kW	N2 R/MIN	i	M2 Nm	Fm	N	UNIT DESIGNATION	Kg	Motor Frame Size
	Output Speed	Ratio	Output Torque	Service Factor	Overhung Load			
4 POLE	181	8.03	757	3.39	34000	K 0 9 3 1 8 . 0 _ M _ - _ - 1 5 . A - -	272	160L
	97	14.94	1408	2.68	34000	1 6 .		
	81	17.93	1700	2.05	34000	1 8 .		
	73	20.03	1893	1.88	34000	2 0 .		
	67	21.61	2040	2.03	34000	2 2 .		
	60	24.14	2280	1.85	34000	2 5 .		
	52	27.78	2621	1.44	34000	2 8 .		
	46	31.67	3005	1.26	34000	3 2 .		
	43	33.47	3162	1.33	34000	3 6 .		
	38	38.16	3596	1.17	34000	4 0 .		

NOTE: If any of the following conditions occur then consult Application Engineering:-

- a) Inertia of the Driven Machine (Referred to motor speed) >10 Inertia of Gear Unit plus Motor b) Ambient temperature is above 40°C

SERIES K

OUTPUT OPTIONS

OUTPUTBORE OPTIONS. COLUMN 11 ENTRY

Standard / Inch Hollow Shaft

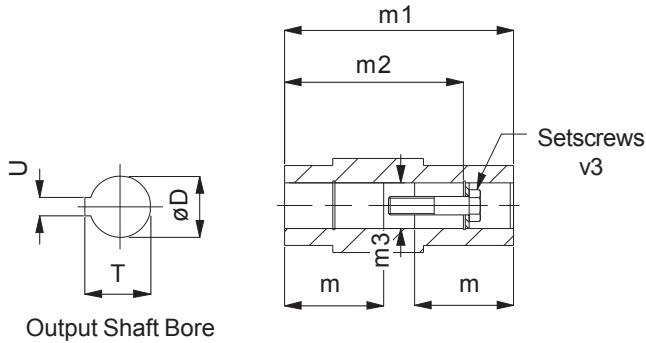

Column 11 Entry

- Standard Hollow Shaft H
- Standard Shrink Disc * X on Left** Y on Right**
- Inch Hollow Shaft A

* See pages 75 for dimensions of these shaft options
** See page 13 for clarification of unit handing

UNIT SIZE	TYPE OF BORE	COL 11 ENTRY	DIMENSIONS IN MM (Inch shaft in inches)							
			Ø D	m	m1	m2	øm3	T	U	v3
K03	Standard	H	30.021 / 30.000	52.5	120	105	30.3	33.5	8	M10x50L
	Inch	A	1.251" / 1.250"	2.07"	4.724"	4.13"	1.26"	1.377"	0.250"	3/8" UNF x 2" LONG
K04	Standard	H	35.025 / 35.000	66	150	132	35.3	38.5	10	M12x55L
	Inch	A	1.376" / 1.375"	2.60"	5.906"	5.12"	1.38"	1.525"	0.3125"	1 1/8" UNF x 2 3/4" LONG
K05	Standard	H	40.025 / 40.000	73	166	142	40.3	43.5	12	M16x70L
	Inch	A	1.501" / 1.500"	2.87"	6.535"	5.59"	1.51"	1.675"	0.375"	5/8" UNF x 2 3/4" LONG
K06	Standard	H	40.025 / 40.000	80	180	156	40.3	43.5	12	M16x70L
	Inch	A	1.501" / 1.500"	3.15"	7.087"	6.14"	1.51"	1.51"	0.375"	5/8" UNF x 2 3/4" LONG
K07	Standard	H	50.025 / 50.000	92.5	210	183	50.5	54	14	M16x70L
	Inch	A	2.001" / 2.000"	3.64"	8.268"	7.20"	2.02"	2.230"	0.500"	5/8" UNF x 2 3/4" LONG
K08	Standard	H	60.030 / 60.000	105	240	210	60.5	64.5	18	M20x80L
	Inch	A	2.3762" / 2.3750"	4.134"	9.449"	8.268"	2.382"	2.656"	0.625"	3/4" - 16 UNF x 3 1/4" LONG
K09	Standard	H	70.030 / 70.000	132.5	300	270	70.5	75	20	M20x80L
	Inch	A	2.7512" / 2.7500"	5.217"	11.811"	10.630"	2.772"	3.037"	0.625"	3/4" - 16 UNF x 3 1/4" LONG
K10	Standard	H	80.030 / 80.000	155	350	313	80.5	85.6	22	M20x80L
	Inch	A	3.2514" / 3.2500"	6.102"	13.780"	12.323"	3.268"	3.591"	0.750"	3/4" - 16 UNF x 3 1/4" LONG
K12	Standard	H	100.035 / 100.000	180	410	373	100.5	106.5	28	M24x110L
	Inch	A	4.0014" / 4.0000"	7.087"	16.142"	14.685"	4.020"	4.446"	1.000"	1" - 12 UNF x 4 1/2" LONG

SERIES K

OUTPUT OPTIONS

OUTPUTSHAFT OPTIONS. COLUMN 11 ENTRY

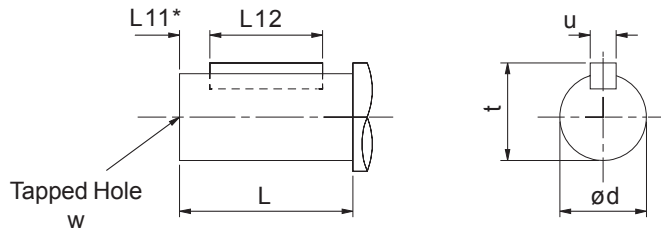

Column 11 Entry

Standard Single Extension C on Left E on Right
 Standard Double Extension D
 Inch Single Extension N on Left B on Right
 Inch Double Extension P

SIZE OF UNIT	TYPE OF OUTPUT SHAFT	COLUMN 11 ENTRY	DIMENSIONS IN MM (Inch shaft in inches)						
			ød	L	L11	L12	t	u	w
K03	Standard Single Ext.	C / E	25.015 / 25.002	47	3	40	28	8	M10 x 1.5 x 22 Deep
	Standard Double Ext.	D	25.015 / 25.002	47	3	40	28	8	M10 x 1.5 x 22 Deep
	Inch Single Ext.	N / B	1.0000" / 0.9995"	1.85"	*	1.57"	1.106"	0.25"	3/8 UNF x 0.75" Deep
	Inch Double Ext.	P	1.0000" / 0.9995"	1.85"	*	1.57"	1.106"	0.25"	3/8 UNF x 0.75" Deep
K04	Standard Single Ext.	C / E	30.015 / 30.002	56	3	50	33	8	M12 x 1.75 x 28 Deep
	Standard Double Ext.	D	30.015 / 30.002	56	3	50	33	8	M12 x 1.75 x 28 Deep
	Inch Single Ext.	N / B	1.2500" / 1.2495"	2.20"	*	2"	1.359"	0.25"	1/2 UNF x 1.13" Deep
	Inch Double Ext.	P	1.2500" / 1.2495"	2.20"	*	2"	1.359"	0.25"	1/2 UNF x 1.13" Deep
K05	Standard Single Ext.	C / E	35.018 / 35.002	66	3	60	38	10	M16 x 2 x 36 Deep
	Standard Double Ext.	D	35.018 / 35.002	66	3	60	38	10	M16 x 2 x 36 Deep
	Inch Single Ext.	N / B	1.3750" / 1.3745"	2.60"	*	2.375"	1.507"	0.3125"	5/8 UNF x 1.5" Deep
	Inch Double Ext.	P	1.3750" / 1.3745"	2.60"	*	2.375"	1.507"	0.3125"	5/8 UNF x 1.5" Deep
K06	Standard Single Ext.	C / E	40.018 / 40.002	76	3	70	43	12	M16 x 2 x 36 Deep
	Standard Double Ext.	D	39.991 / 39.975	76	3	70	43	12	M16 x 2 x 36 Deep
	Inch Single Ext.	N / B	1.625" / 1.624"	3.00"	*	2.375"	1.784"	0.375"	5/8 UNF x 1.5" Deep
	Inch Double Ext.	P	1.4996" / 1.4990"	3.00"	*	2.375"	1.664"	0.375"	5/8 UNF x 1.5" Deep
K07	Standard Single Ext.	C / E	50.018 / 50.002	95	3	80	53.5	14	M16 x 2 x 36 Deep
	Standard Double Ext.	D	49.991 / 49.975	95	3	80	53.5	14	M16 x 2 x 36 Deep
	Inch Single Ext.	N / B	2.000" / 1.999"	3.74"	*	2.75"	2.228"	0.50"	5/8 UNF x 1.5" Deep
	Inch Double Ext.	P	2.000" / 1.999"	3.74"	*	2.75"	2.228"	0.50"	5/8 UNF x 1.5" Deep
K08	Standard Single Ext.	C / E	60.030 / 60.011	114	3	100	64	18	M20 x 2.5 42 Deep
	Standard Double Ext.	D	59.990 / 59.971	114	3	100	64	18	M20 x 2.5 42 Deep
	Inch Single Ext.	N / B	2.3750" / 2.3740"	4.488"	*	3.6875"	2.65"	0.625"	3/4" 16 UNF x 1.65 Deep
	Inch Double Ext.	P	2.3746" / 2.3739"	4.488"	*	3.6875"	2.65"	0.625"	3/4" 16 UNF x 42 Deep
K09	Standard Single Ext.	C / E	70.030 / 70.011	135	3	110	74.5	20	M20 x 2.5 x 42 Deep
	Standard Double Ext.	D	69.990 / 69.971	135	3	110	74.5	20	M20 x 2.5 x 42 Deep
	Inch Single Ext.	N / B	2.875" / 2.874"	5.315"	*	4.625"	3.20"	0.750"	3/4" 16 UNF x 1.65 Deep
	Inch Double Ext.	P	2.625" / 2.624"	5.315"	*	3.6875"	3.03"	0.625"	3/4" 16 UNF x 42 Deep
K10	Standard Single Ext.	C / E	90.035 / 90.013	172	5	140	95	25	M20 x 2.5 x 42 Deep
	Standard Double Ext.	D	75.030 / 75.011	163	5	110	79.5	20	M20 x 2.5 x 42 Deep
	Inch Single Ext.	N / B	3.625" / 3.624"	6.772"	*	5.9375"	4.01"	0.875"	3/4" 16 UNF x 1.65 Deep
	Inch Double Ext.	P	3.125" / 3.124"	6.417"	*	4.625"	3.45"	0.750"	3/4" 16 UNF x 42 Deep
K12	Standard Single Ext.	C / E	110.035 / 110.013	213	5	180	116	28	M24 x 3 x 55 Deep
	Standard Double Ext.	D	95.035 / 95.013	200	5	140	100	25	M20 x 2.5 x 42 Deep
	Inch Single Ext.	N / B	4.375" / 4.374"	8.386"	*	6.500"	4.81"	1.000"	1" 12 UNF x 2.17 Deep
	Inch Double Ext.	P	3.875" / 3.874"	7.874"	*	6.500"	4.31"	1.000"	1" 12 UNF x 55 Deep

* Inch shaft has an open ended keyway, therefore no 'L11' dimension is required

SERIES K

MOTOR ADAPTERS

IEC & NEMA

TRIPLE REDUCTION UNITS

IEC Flanges B14 - Column 12 Entry For Unit Types Column 10 Entries G, H and M Only

MOTOR FRAME FLANGE	UNIT SIZE, NUMBER OF REDUCTIONS, REVISION NUMBER										
	RATIO COVERAGE	K0332		K0432		K0532		K0632		K0732	
		8.0 - 20.	25. - 125	8.0 - 32.	36. - 125	8.0 - 25.	28. - 125	8.0 - 25.	28. - 125	8.0 - 20.	25. - 125
71	COLUMN 12 ENTRY	H	H	-	H	-	F	-	F	-	-
80		B	K	B	K	-	G	-	G	-	G
90		D	R	D	R	Z	J	Z	J	-	J
100		E	S	E	S	B	L	B	L	B	L
112		E	S	E	S	B	L	B	L	B	L
132		-	-	-	-	-	-	-	-	D	N

IEC Flanges B5 - Column 12 Entry For Unit Types Column 10 Entries G, H and M Only

MOTOR FRAME FLANGE	UNIT SIZE, NUMBER OF REDUCTIONS, REVISION NUMBER																		
	RATIO COVERAGE	K0332		K0432		K0532		K0632		K0732		K0832		K0931		K1031		K1231	
		8.0 - 20.	25. - 125	8.0 - 32.	36. - 125	8.0 - 25.	28. - 125	8.0 - 25.	28. - 125	8.0 - 20.	25. - 125	8.0 - 32.	36. - 125	8.0 - 40.	45. - 160	8.0 - 40.	45. - 160	8.0 - 40.	45. - 100
63	F	F	-	F	-	V	-	V	-	-	-	-	-	-	-	-	-	-	-
71	G	G	-	G	-	D	-	D	-	-	-	-	-	-	-	-	-	-	-
80	A	J	A	J	W	F	W	F	-	F	-	D	-	E	-	-	-	-	-
90	C	Q	C	Q	Y	H	Y	H	-	H	-	E	-	F	-	-	-	-	-
100	-	-	-	-	A	K	A	K	A	K	A	F	-	G	-	E	-	G	N
112	-	-	-	-	A	K	A	K	A	K	A	F	-	G	-	E	-	G	N
132	-	-	-	-	N	P	N	-	C	M	B	G	-	H	-	F	-	H	P
160	-	-	-	-	-	-	-	-	E	-	C	H	A	J	A	G	A	J	Q
180	-	-	-	-	-	-	-	-	-	-	-	-	B	K	B	H	B	K	R
200	-	-	-	-	-	-	-	-	-	-	-	-	C	-	C	-	C	L	S
225	-	-	-	-	-	-	-	-	-	-	-	-	D	-	D	-	D	M	T
250	-	-	-	-	-	-	-	-	-	-	-	-	-	-	-	-	E	U	-
280	-	-	-	-	-	-	-	-	-	-	-	-	-	-	-	-	F	W	-

Limited Availability / Non Preferred

NEMA Flanges C Face - Column 12 Entry For Unit Types Column 10 Entries A, E and N Only

MOTOR FRAME FLANGE	UNIT SIZE, NUMBER OF REDUCTIONS, REVISION NUMBER																		
	RATIO COVERAGE	K0332		K0432		K0532		K0632		K0732		K0832		K0931		K1031		K1231	
		8.0 - 20.	25. - 125	8.0 - 32.	36. - 125	8.0 - 25.	28. - 125	8.0 - 25.	28. - 125	8.0 - 20.	25. - 125	8.0 - 32.	36. - 125	8.0 - 40.	45. - 160	8.0 - 40.	45. - 160	8.0 - 40.	45. - 100
56c	T	U	T	U	-	Q	-	Q	-	Q	-	M	-	-	-	-	-	-	-
143/145TC	V	W	V	W	-	R	-	R	-	R	-	N	-	-	-	-	-	-	-
182/184TC	X	-	X	-	S	T	S	T	S	T	J	P	-	S	-	P	-	N	A
213/215TC	-	-	-	-	U	-	U	-	U	V	K	Q	-	T	-	Q	-	P	B
254/256TC	-	-	-	-	-	-	-	-	W	-	L	U	P	U	L	R	F	Q	C
284/286TC	-	-	-	-	-	-	-	-	-	-	-	-	Q	V	M	S	G	R	D
324/326TC	-	-	-	-	-	-	-	-	-	-	-	-	R	W	N	T	H	S	E
364/365TC	-	-	-	-	-	-	-	-	-	-	-	-	-	-	-	-	J	T	-
404/405TC	-	-	-	-	-	-	-	-	-	-	-	-	-	-	-	-	K	U	-

SERIES K

MOTOR ADAPTERS

IEC & NEMA

QUINTUPLE REDUCTION UNITS

IEC Flanges B14 - Column 12 Entry For Unit Types Column 10 Entries G, H and M Only

MOTOR FRAME FLANGE	UNIT SIZE, NUMBER OF REDUCTIONS, REVISION NUMBER																		
	RATIO COVERAGE	K0352		K0452		K0552		K0652		K0752		K0852		K0951		K1051		K1251	
		125 - 250	280 & Over	125 - 360	400 & Over	125 - 400	450 & Over	125 - 400	450 & Over	125 - 400	450 & Over	125 - 400	450 & Over	160 - 500	560 & Over	160 - 500	560 & Over	160 - 500	560 & Over
71	COLUMN 12 ENTRY																		
80																			
90																			
100																			
112																			
132																			

IEC Flanges B5 - Column 12 Entry For Unit Types Column 10 Entries G, H and M Only

MOTOR FRAME FLANGE	UNIT SIZE, NUMBER OF REDUCTIONS, REVISION NUMBER																		
	RATIO COVERAGE	K0352		K0452		K0552		K0652		K0752		K0852		K0951		K1051		K1251	
		125 - 250	280 & Over	125 - 360	400 & Over	125 - 400	450 & Over	125 - 400	450 & Over	125 - 400	450 & Over	125 - 400	450 & Over	160 - 500	560 & Over	160 - 500	560 & Over	160 - 500	560 & Over
63	COLUMN 12 ENTRY																		
71																			
80																			
90																			
100																			
112																			
132																			
160																			

Limited Availability / Non Preferred

NEMA Flanges C Face - Column 12 Entry For Unit Types Column 10 Entries A, E and N Only

MOTOR FRAME FLANGE	UNIT SIZE, NUMBER OF REDUCTIONS, REVISION NUMBER																		
	RATIO COVERAGE	K0352		K0452		K0552		K0652		K0752		K0852		K0951		K1051		K1251	
		125 - 250	280 & Over	125 - 360	400 & Over	125 - 400	450 & Over	125 - 400	450 & Over	125 - 400	450 & Over	125 - 400	450 & Over	160 - 500	560 & Over	160 - 500	560 & Over	160 - 500	560 & Over
56c	COLUMN 12 ENTRY																		
143/145TC																			
182/184TC																			
213/215TC																			
254/256TC																			

SERIES K

LUBRICATION

K03,K04,K05,K06,& K07 Units & Primary Units used for Quintuple Reduction, are supplied factory filled with EP mineral oil (Grade 6E) appropriate to the intended mounting position. If the unit is supplied without lubricant the unit must be filled with the correct lubricant and quantity as listed below:

K08,K09,K10,& K12 Units, require filling with EP mineral oil (Grade 6E)

Lubricant quantities are approximate fill until oil escapes from the level plug hole, fit ventilator plug (when supplied) in the appropriate position for the required mounting position (see installation and maintenance instructions)

TEMPERATURE LIMITATIONS

The standard lubricant is suitable for operation in ambient temperatures of 0° to 35°C, outside of this consult Table 1 or consult Application Engineering.

TABLE 1 OIL GRADES

LUBRICANT	AMBIENT TEMPERATURE RANGE		
	-5°C to 20°C (type E) -30°C to 20°C (type H)	0°C to 35°C	20°C to 50°C
EP Mineral Oil (type E)	5E (VG 220)	6E (VG 320)	7E (VG 460)
Polyalphaolefin based Synthetic (type H)	5H (VG 220)	5H (VG 220)	6H (VG 320)

Lubricant Quantities (Litres)

TRIPLE REDUCTION										
Unit Size	K0332	K0432	K0532	K0632	K0732	K0832	K0931	K1031	K1231	
MOUNTING POSITION	1	0.5	0.7	1.1	1.5	2.7	4.4	9.3	15	23
	2	0.7	0.9	1.5	1.8	3.6	3.7	8.3	15	27
	3	0.8	1.1	1.7	2.8	4.0	7.6	18	28	33
	4	1.0	1.3	1.9	2.7	4.5	7.5	17	30	39
	5	1.2	1.7	2.5	3.6	5.7	9.6	21	34	50
	6	0.9	1.2	2.0	2.6	4.5	7.6	16	25	35

QUINTUPLE REDUCTION											
Unit Size	K0352		K0452		K0552		K0652		K0752		
	Primary	Secondary	Primary	Secondary	Primary	Secondary	Primary	Secondary	Primary	Secondary	
	M0122	K0332	M0122	K0432	M0322	K0532	M0322	K0632	M0322	K0732	
MOUNTING POSITION	1	0.5	0.5	0.5	0.7	0.8	1.1	0.8	1.5	0.8	2.7
	2	0.5	0.7	0.5	0.9	0.8	1.5	0.8	1.8	0.8	3.6
	3	0.5	0.8	0.5	1.1	0.8	1.7	0.8	2.8	0.8	4.0
	4	0.5	1.0	0.5	1.3	0.8	1.9	0.8	2.7	0.8	4.5
	5	0.7	1.2	0.7	1.7	1.1	2.5	1.1	3.6	1.1	5.7
	6	1.0	0.9	1.0	1.2	1.4	2.0	1.4	2.6	1.4	4.5

QUINTUPLE REDUCTION..CONT									
Unit Size	K0852		K0951		K1051		K1251		
	Primary	Secondary	Primary	Secondary	Primary	Secondary	Primary	Secondary	
	M0522	K0832	M0522	K0931	M0722	K1031	M0722	K1231	
MOUNTING POSITION	1	1.5	4.4	1.5	9.3	2.6	15	2.6	23
	2	1.5	3.7	1.5	8.3	2.6	15	2.6	27
	3	1.5	7.6	1.5	18	2.6	28	2.6	33
	4	1.5	7.5	1.5	17	2.6	30	2.6	39
	5	2.0	9.6	2.0	21	3.2	34	3.2	50
	6	2.6	7.6	2.6	16	4.7	25	4.7	35

SERIES K

MOUNTING POSITIONS

COLUMN 13 ENTRY

Enter for units with no oil fill

Base Mounted Units

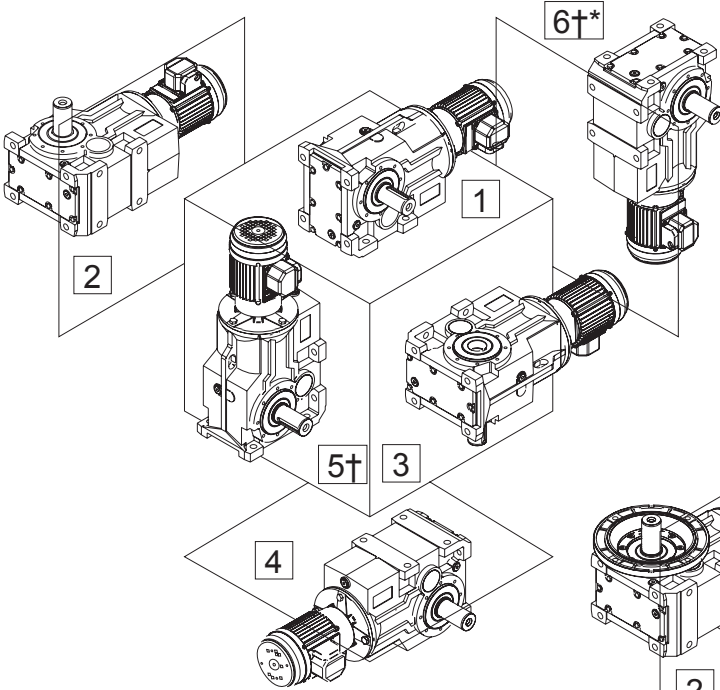

Flange Mounted Units

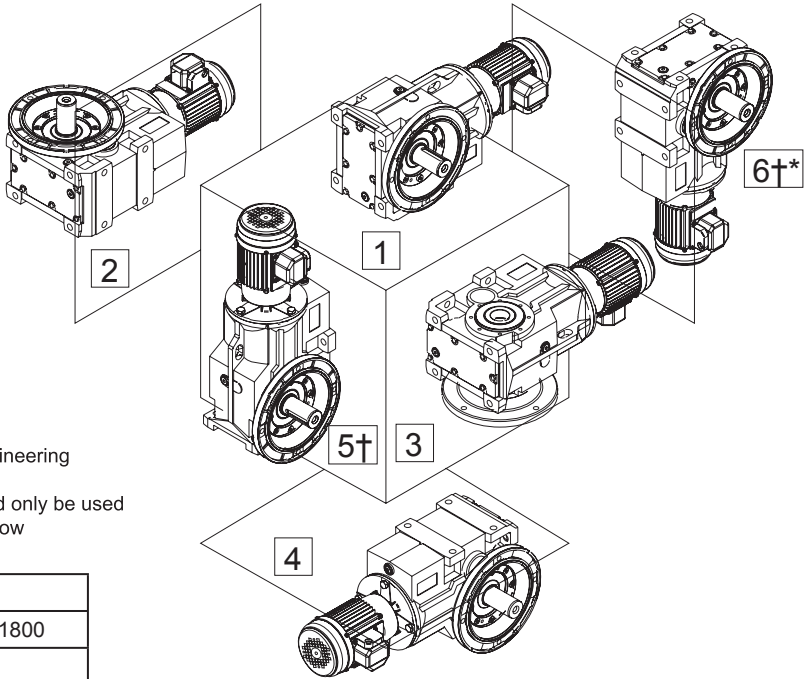

* Not Recommended for Geared Motors - Consult Application Engineering

† Gear Units selected for use in mounting positions 5 and 6 should only be used with overall ratios greater or equal to those shown in the table below

Unit Size	Input Speed (rpm)				Consult Application Engineering
	< 1000	< 1500	< 1800	> 1800	
K08	All	All	All		Consult Application Engineering
K09	All	11.0	14.0		
K10	11.0	20	25.0		
K12	16.0	32	36.0		

MOUNTING POSITIONS - SHOWN AS MOTORISED - APPLIES ALSO FOR REDUCERS

COLUMN 14 ENTRY

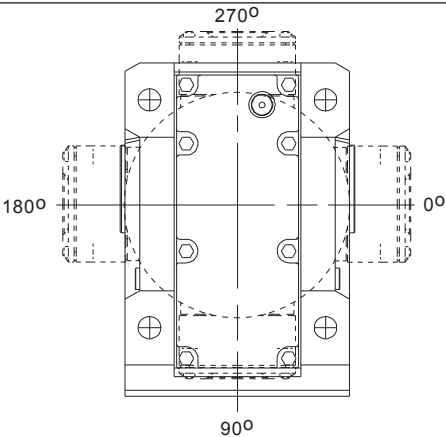

ALL MOTORS



Column 14 Entry	Terminal Box Position
A	0°
B	90°
C	180°
D	270°
-	Reducer or no motor fitted

SERIES K

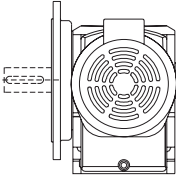
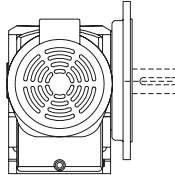
UNIT HANDINGS

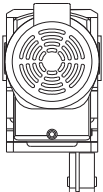
Column 9 Entry	Left	Right
Std Unit with Output Flange	F 	H 
Std Unit with Torque Bracket	T 	Q 

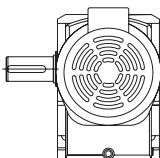
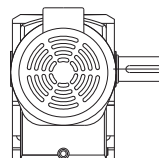
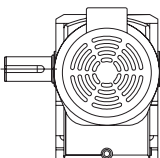
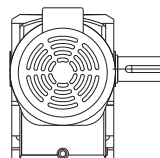
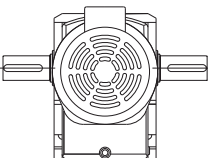
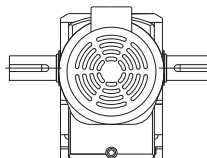
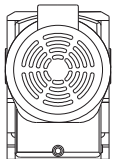
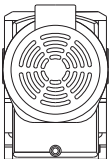
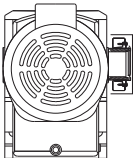
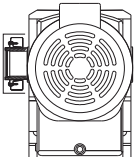
Column 11 Entry	Metric		Inch	
	Left	Right	Left	Right
Single Output Shaft	C 	E 	N 	B 
Double Output Shaft	D 		P 	
Hollow Shaft	H 		A 	
Shrink Disc	Y  Driven Machine Side	X  Driven Machine Side		

Note: non-standard handing, please contact Application Engineering

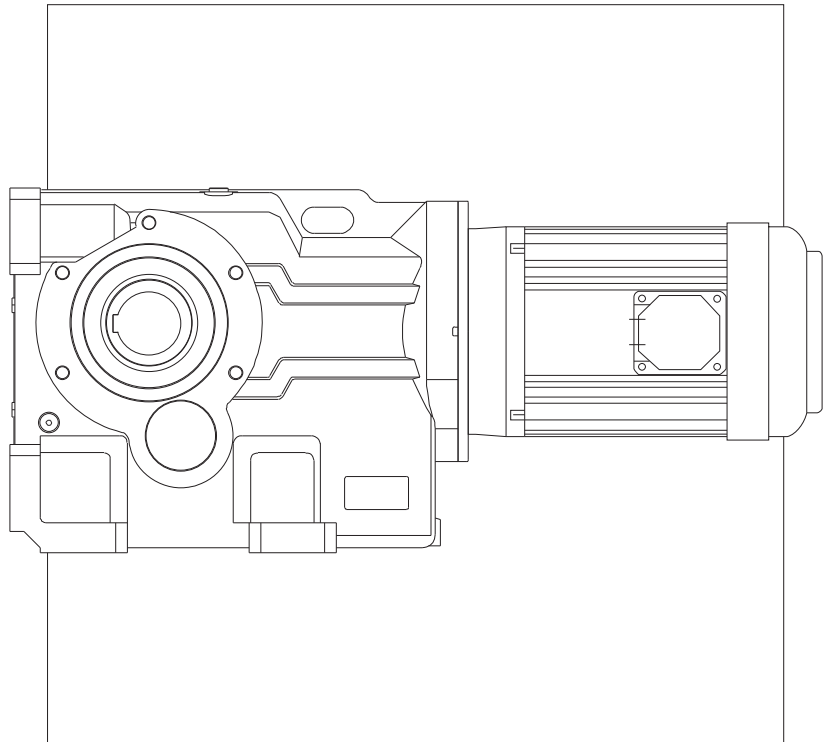

**MOTORISED
SERIES K**

SERIES K MOTOR PERFORMANCE DATA

**TEFC squirrel cage three phase motors
4 poles = 1500 rpm 400V, 50Hz, S1 IP55, Class F**

Output Power Kw	Frame Size	Speed (RPM)	I (A)	Ist	Tst	J
				I	T	(Kgm2)
0.12	63	1360	0.6	2.6	2.5	0.000
0.18	63	1370	0.72	3	2.2	0.000
0.25	71	1400	0.83	3.5	2.2	0.001
0.37	71	1410	1.12	4	2.2	0.001
0.55	80A	1420	1.45	4	2.2	0.002
0.75	80A	1420	1.8	4.5	2.2	0.002
1.1	90S	1410	2.59	5	2.2	0.003
1.5	90L	1420	3.45	5	2.4	0.004
2.2	100L	1430	4.8	5.5	2.4	0.007
3	100L	1430	6.48	5.5	2.5	0.008
4	100L	1420	8.73	5.5	2.5	0.009
4	112M	1435	8.6	7	2.9	0.015
5.5	112M	1425	11.4	7.1	2.8	0.018
5.5	132S	1450	11.1	7.3	2.2	0.031
7.5	132M	1450	14.8	7.9	2.5	0.038
9	132M	1450	18	8.1	2.8	0.043
11	132M	1450	21	8.3	3	0.048
11	160M	1460	21.5	6.7	2.9	0.067
15	160L	1455	28.5	6.8	2	0.091
18.5	160L	1450	36	6.9	2.9	0.102
18.5	180M	1470	35	6.7	3.1	0.161
22	180L	1470	41	6.8	2.9	0.191
30	180L	1465	56	6.9	3.2	0.225
30	200L	1475	56	6.7	2.6	0.29
37	200L	1475	68	7.8	3.6	0.34
37	225S	1480	68	6.6	2.4	0.37
45	225M	1480	83	6.7	2.7	0.42
55	225M	1480	100	7.3	3.1	0.49
55	250M	1480	98	7.5	2.3	0.72
75	250M	1480	132	7	2.4	0.88
75	280S	1483	137	6.8	2.4	1.15
90	280M	1484	163	7.1	2.7	1.4
110	280M	1483	195	7.5	2.7	1.7

High Power Motor (Non Standard)

I = Nominal current
Ist/I = Starting current factor
Tst/T = Starting torque factor
J = Motor moment of inertia

Recalculation Factors

Recalculation factors for current at rated voltages other than 400V, 50 Hz.

Rated voltage at 50Hz and motor wound for	Recalculation factor
220V	1.82
230V	1.74
415V	0,96
500V	0,80
660V	0,61
690V	0,58

**TEFC squirrel cage three phase motors
6 poles = 1000 rpm 400V, 50Hz, S1 IP55, Class F**

Output Power Kw	Frame Size	Speed (RPM)	I (A)	Ist	Tst	J
				I	T	(Kgm2)
0.12	63	900	0.6	2.1	2.1	0.000
0.18	71	920	0.75	2.5	2	0.001
0.25	71	920	0.92	3	2	0.001
0.37	80A	920	1.25	3.5	2.1	0.002
0.55	80B	930	1.78	3.5	2.1	0.002
0.75	90S	930	2.36	4	1.9	0.003
1.1	90L	930	3.25	4	1.9	0.004
1.5	100L	940	5.8	4.5	1.9	0.009
2.2	112M	940	5.8	4.5	1.9	0.009
2.2	100L	940	5.4	5.6	2.1	0.015
3	112M	935	7.2	5.5	2.4	0.018
3	132S	960	6.9	6.1	2.4	0.031
4	132M	960	8.7	7.1	2.6	0.038
5.5	132M	955	11.9	6.9	2.8	0.045
7.5	160M	970	15.4	6.7	2	0.089
11	160L	970	23	7.1	2.2	0.107
15	180L	970	31	7	2.1	0.217
18.5	180L	965	37.5	6.2	2	0.237
18.5	200L	985	36	7	2.5	0.370
22	200L	980	43	7.2	2.5	0.430
30	200L	980	56	7.5	3.3	0.490
30	225M	985	56	6.6	2.5	0.640
37	225S	985	69	7.7	3.1	0.750
37	250M	985	69	7.3	2.8	1.160
45	250S	985	82	7.3	2.8	1.490
45	280S	990	85	6.6	2.6	1.650

High Power Motor (Non Standard)

I = Nominal current
Ist/I = Starting current factor
Tst/T = Starting torque factor
J = Motor moment of inertia

60 Hz Operation

Motors wound for a certain voltage at 50 Hz can be operated at 60 Hz, without any modifications, subject to the following changes in their data

Motor wound for 50 Hz and	Connected to 60 Hz and	Data at 60 Hz in percentage of values at 50 Hz					
		P kW	n rpm	I A	Ist/I	T Nm	Tst/T
400V	380V	100	120	100	80	83	66
	400V	100	120	98	83	83	70
	415V	105	120	100	88	86	78
	440V	110	120	100	95	91	85
	460V	115	120	100	100	96	95
	480V	120	120	100	105	100	100

SERIES K

MOTOR DETAILS

B14 'C' FACE

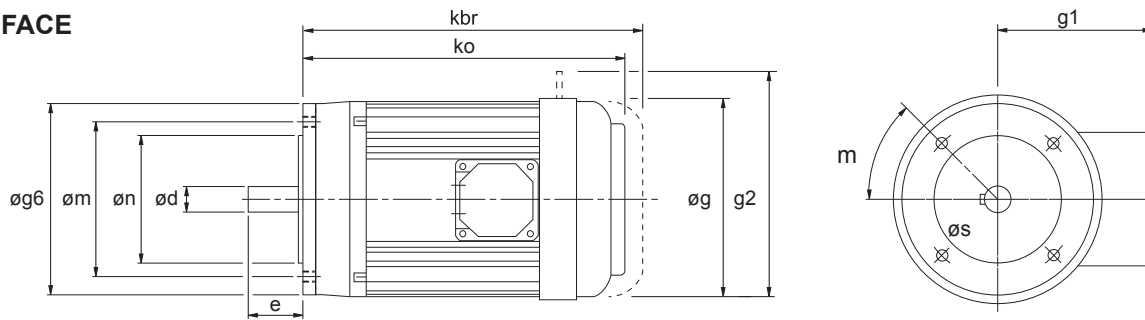

MOTOR FRAME SIZE	Øg6	Øm	Øn	Ød	e	ko*	kbr*	Øg	g1*	m	Øs
71	105	85	70	14	30	221	265	138	102	45°	4 x M6
80A	120	100	80	19	40	239	291	157	125	45°	4 x M6
80B	120	100	80	19	40	248	300	157	125	45°	4 x M6
90S	140	115	95	24	50	260	312	177	133	45°	4 x M8
90L	140	115	95	24	50	275	327	177	133	45°	4 x M8
100L	160	130	110	28	60	310	370	197	144	45°	4 x M8
112M	160	130	110	28	60	325	399	219	155	45°	4 x M8
132S	200	165	130	38	80	392	475	235	172	45°	4 x M10
132M	200	165	130	38	80	412	495	235	172	45°	4 x M10

B5 'D' FACE

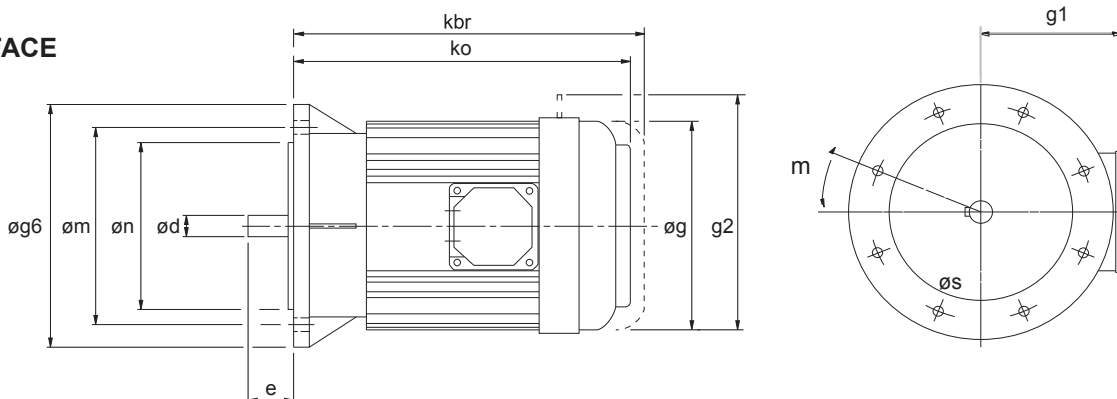

MOTOR FRAME SIZE	Øg6	Øm	Øn	Ød	e	ko*	kbr*	Øg	g1*	m	Øs
63	140	115	95	11	23	218	263	122	96	45°	4 x M8
71	160	130	110	14	30	221	265	138	102	45°	4 x M8
80A	200	165	130	19	40	239	291	157	125	45°	4 x M10
80B	200	165	130	19	40	248	300	157	125	45°	4 x M10
90S	200	165	130	24	50	260	312	177	133	45°	4 x M10
90L	200	165	130	24	50	275	327	177	133	45°	4 x M10
100L	250	215	180	28	60	310	370	197	144	45°	4 x M12
112M	250	215	180	28	60	325	399	219	155	45°	4 x M12
132S	300	265	230	38	80	392	475	235	172	45°	4 x M12
132M	300	265	230	38	80	412	495	235	172	45°	4 x M12
160M	350	300	250	42	110	455	538	273	282	45°	4 x M16
160L	350	300	250	42	110	500	583	273	282	45°	4 x M16
180M	350	300	250	48	110	557	-	382	307	22.5°	4 x M16
180L	350	300	250	48	110	595	-	382	307	22.5°	4 x M16
200L	400	350	300	55	110	658	-	420	372	-	4 x M16
225S	450	400	350	60	140	671	-	458	427	-	8 x M16
225M	450	400	350	60	140	696	-	458	427	-	8 x M16
250M	550	500	450	65	140	771	-	510	490	-	8 x M16
280S	550	500	450	75	140	837	-	576	520	-	8 x M16
280M	550	500	450	75	140	888	-	576	520	-	8 x M16

* Motor lengths for own brand standard motors. These lengths may vary if alternative motor is fitted.

SERIES K ADDITIONAL MOTOR FEATURES

ADDITIONAL MOTOR FEATURES - COLUMN 19 ENTRY

Column 19 Entry	Brake Motor	Hand Release on Brake	Forced Ventilation/ Constant Blower (TECB)	Thermistors	Special
-					
A	•				
B	•	•			
C			•		
D	•		•		
E	•	•	•		
F				•	
G	•			•	
H	•	•		•	
K			•	•	
L	•		•	•	
M	•	•	•	•	
S					•

Please refer to Application Engineering for details of the following additional motor features

- PGF encoder flange
- Wash down
- Customised brake torque
- Separate brake supply
- Aluminium fan
- Anti Condensation heater
- Bi-metal temperature detectors, Thermostat
- EExEIIT3
- Ex nA II T3
- IP56
- IP65
- Metal fan cover
- Rain cowl
- Separate terminal box

SERIES K ADDITIONAL GEARBOX FEATURES

ADDITIONAL GEARBOX FEATURES - COLUMN 20 ENTRY

Column 20 Entry	Double Outputshaft Oil Seals	Oil Level Glass K07 - K12	* Motorised Backstop		Special
			CW Rotation	CCW Rotation	
-					
A	•				
B		•			
C	•	•			
D			•		
E	•		•		
F		•	•		
G	•	•	•		
H				•	
I	•			•	
J		•		•	
K	•	•		•	
L					•

Please refer to Application Engineering for details of the special additional gearbox features for example :-

- Prime paint only
- Wash down
- BISSC compatible
- Special oil (food compatible, bio-degradable, different viscosities etc)

* IEC Frame Sizes 100-200, NEMA frame sizes 182TC - 326TC

SERIES K EXACT RATIOS

EXACT RATIOS - TRIPLE REDUCTION

Column Entry			K0332	K0432	K0532	K0632	K0732	K0832	K0931	K1031	K1231
6	7	8									
8.0			8.328	8.054	8.112	7.961	8.595	8.128	8.035	8.263	8.513
10.			-	-	-	-	-	-	9.681	9.946	10.26
11.			11.25	11.30	11.41	11.19	11.91	11.52	11.06	11.54	11.80
12.			12.80	12.45	12.78	12.55	13.37	12.80	12.40	12.55	12.96
14.			14.50	14.14	14.35	14.08	14.71	14.24	13.33	13.89	14.21
16.			-	-	-	-	-	-	14.94	15.11	15.61
18.			18.54	17.95	18.22	17.88	19.21	18.41	17.93	18.57	18.20
20.			19.98	20.40	20.66	20.27	21.84	20.67	20.04	20.05	20.17
22.			-	-	-	-	-	-	21.61	22.35	21.93
25.			25.23	25.03	24.64	24.18	26.52	25.34	24.14	24.13	24.29
28.			28.60	27.76	28.37	27.84	29.17	28.56	27.78	29.24	29.00
32.			32.68	31.54	32.99	32.38	33.52	33.24	31.67	33.10	32.83
36.			36.35	35.83	36.91	36.23	38.01	36.88	33.47	35.20	34.93
40.			40.08	39.46	39.34	38.61	41.92	40.36	38.16	39.84	39.55
45.			44.11	45.39	46.63	45.76	48.01	45.66	44.89	45.37	46.81
50.			51.68	49.35	49.78	48.86	54.28	51.54	49.88	50.41	52.76
56.			-	-	-	-	-	-	54.09	54.61	56.39
63.			62.00	59.24	61.78	60.63	62.94	62.48	60.09	60.68	63.57
71.			72.27	71.09	72.85	71.49	75.07	72.86	70.45	71.89	74.62
80.			80.30	80.10	79.77	78.28	82.20	80.03	77.78	82.83	83.10
90.			f	-	-	-	-	-	84.89	86.53	89.89
100			96.70	93.12	97.76	95.93	98.65	98.08	93.71	99.70	100.1
112			110.8	105.7	109.0	106.9	113.5	107.1	107.0	112.0	113.8
125			126.0	120.2	122.2	119.9	126.1	123.3	120.3	120.4	121.1
140			-	-	-	-	-	-	128.9	134.8	137.1
160			-	-	-	-	-	-	145.0	144.9	146.9

SERIES K EXACT RATIOS

EXACT RATIOS - QUADRUPLE REDUCTION

Column Entry			K0352	K0452	K0552	K0652	K0752	K0852	K0951	K1051	K1251
6	7	8									
125			128	134	118	116	120	132	-	-	-
140			145	148	143	140	133	145	-	-	-
160			165	170	157	154	147	164	161	167	172
200			211	200	208	204	211	203	226	231	238
250			227	258	264	259	233	228	254	260	269
280			287	284	300	294	265	268	282	285	302
320			325	322	316	310	305	297	298	317	332
360			371	355	351	344	374	337	331	373	385
400			413	407	399	391	415	401	402	414	437
450			455	448	453	445	466	462	455	471	493
500			516	508	499	489	513	506	489	515	531
560			568	581	574	563	590	538	563	566	584
630			649	646	624	612	641	641	655	651	671
700			704	712	725	712	737	760	727	723	757
800			798	808	812	797	836	811	789	783	809
900			912	891	899	882	924	888	940	904	946
10C			1015	1000	1045	1026	1062	1007	1028	980	1012
11C			1119	1102	1169	1147	1204	1102	1115	1171	1140
12C			1183	1267	1231	1208	1267	1246	1190	1268	1226
14C			1423	1427	1477	1449	1521	1470	1477	1470	1519
16C			1583	1606	1577	1548	1720	1659	1641	1634	1712
18C			1800	1784	1777	1744	1938	1817	1741	1754	1811
20C			2000	2250	1957	1920	1994	2011	1935	1949	2042
22C			2250	2265	2205	2164	2246	2202	2118	2134	2236
25C			2579	2463	2563	2515	2611	2699	2596	2561	2683
28C			2699	2799	2847	2794	2934	2821	2733	2779	2887
32C			3094	3360	3310	3248	3411	3147	2992	3044	3162
36C			3516	3548	3757	3686	3871	3853	3667	3652	3794
40C			4007	3998	4056	3981	4093	4237	4048	4208	4226
45C			4554	4543	4604	4518	4646	4722	4512	4842	4862
50C			4826	4647	5131	5036	5281	5157	5060	5380	5110
56C			5485	5281	5234	5136	5345	5296	5793	5845	5879
63C			6286	5994	5833	5725	6076	5783	6207	6548	6657
71C			7144	6815	6542	6420	6752	6660	6980	7276	7083

SERIES K

SELECTION TABLES

GEARED MOTORS

0.12 kW

4 POLE

6 POLE

NOTE

Other output speeds are available using 2 and 8 pole motors - Consult Application Engineering

N2 R/MIN	i	M2 Nm	Fm	N	Unit Designation	Kg	Motor Size
Output Speed	Ratio	Output Torque	Service Factor	Overhung Load	Column Entry 1 Through 20 Spaces to be filled when entering order	Weight of base mount unit	
163	8.33	6	20.32	4300	K 0 3 3 2 8 . 0 _ M _ _ _ _ . 1 2 A - -	20.5	63
121	11.25	9	16.96	4730	1 1 .		
106	12.8	10	15.63	4930	1 2 .		
94	14.5	11	14.46	5130	1 4 .		
73	18.54	15	12.19	5550	1 8 .		
68	19.98	16	11.57	5680	2 0 .		
54	25.23	20	9.77	6000	2 5 .		
48	28.6	23	8.91	6000	2 8 .		
42	32.68	26	8.13	6000	3 2 .		
37	36.35	29	7.5	6000	3 6 .		
34	40.08	32	6.9	6000	4 0 .		
31	44.11	35	6.27	6000	4 5 .		
26	51.68	41	5.36	6000	5 0 .		
22	62	50	4.47	6000	6 3 .		
19	72.27	58	3.85	6000	7 1 .		
17	80.3	64	3.46	6000	8 0 .		
14	96.7	78	2.38	6000	1 0 0		
12	110.83	89	1.78	6000	1 1 2		
11	125.96	101	1.54	6000	1 2 5		
11	127.79	99	2.27	6000	K 0 3 5 2 1 2 5 _ M _ _ _ _ . 1 2 A - -	29.5	63
9.4	145.34	112	1.99	6000	1 4 0		
8.3	164.66	127	1.76	6000	1 6 0		
6.5	210.58	163	1.37	6000	2 0 0		
6	226.95	176	1.27	6000	2 5 0		
4.7	286.52	222	1.01	6000	2 8 0		
4.2	324.82	252	0.89	6000	3 2 0		
9.2	147.98	115	3.83	6000	K 0 4 5 2 1 4 0 _ M _ _ _ _ . 1 2 A - -	34.5	63
8	170.21	131	3.35	6000	1 6 0		
6.8	199.9	155	2.83	6000	2 0 0		
5.3	257.59	200	2.2	6000	2 5 0		
4.8	284.33	219	2.01	6000	2 8 0		
4.2	322.4	251	1.75	6000	3 2 0		
3.8	355.03	277	1.59	6000	3 6 0		
3.3	407.03	318	1.39	6000	4 0 0		
3	448.23	349	1.26	6000	4 5 0		
2.7	508.14	396	1.11	6000	5 0 0		
2.3	580.67	453	0.97	6000	5 6 0		
2.1	645.94	503	0.88	6000	6 3 0		
104	8.33	10	14.12	4860	K 0 3 3 2 8 . 0 _ M _ _ _ _ . 1 2 C - -	20.5	63
77	11.25	14	11.86	5330	1 1 .		
68	12.8	16	10.88	5550	1 2 .		
60	14.5	18	10.04	5770	1 4 .		
47	18.54	23	8.46	6000	1 8 .		
44	19.98	25	8.01	6000	2 0 .		
34	25.23	32	6.8	6000	2 5 .		
30	28.6	36	6.17	6000	2 8 .		
27	32.68	41	5.4	6000	3 2 .		
24	36.35	46	4.87	6000	3 6 .		
22	40.08	51	4.41	6000	4 0 .		
20	44.11	56	4.01	6000	4 5 .		
17	51.68	65	3.43	6000	5 0 .		
14	62	78	2.86	6000	6 3 .		
12	72.27	91	2.45	6000	7 1 .		
11	80.3	101	2.21	6000	8 0 .		
9	96.7	122	1.52	6000	1 0 0		
7.8	110.83	139	1.14	6000	1 1 2		
6.9	125.96	158	0.99	6000	1 2 5		
6.8	127.79	156	1.44	6000	K 0 3 5 2 1 2 5 _ M _ _ _ _ . 1 2 C - -	29.5	63
6	145.34	177	1.26	6000	1 4 0		
5.3	164.66	201	1.12	6000	1 6 0		
4.1	210.58	257	0.87	6000	2 0 0		
3.8	226.95	277	0.81	6000	2 5 0		
8.2	105.69	133	3.25	6000	K 0 4 3 2 1 1 2 _ M _ _ _ _ . 1 2 C - -	26.5	63
7.2	120.15	151	2.92	6000	1 2 5		
6.5	134.38	164	2.68	6000	K 0 4 5 2 1 2 5 _ M _ _ _ _ . 1 2 C - -	34.5	63
5.9	147.98	181	2.43	6000	1 4 0		
5.1	170.21	207	2.12	6000	1 6 0		
4.4	199.9	245	1.8	6000	2 0 0		
3.4	257.59	316	1.4	6000	2 5 0		
3.1	284.33	346	1.27	6000	2 8 0		
2.7	322.4	396	1.11	6000	3 2 0		
2.5	355.03	435	1.01	6000	3 6 0		
2.1	407.03	499	0.88	6000	4 0 0		
1.9	448.23	550	0.8	6000	4 5 0		

SERIES K

SELECTION TABLES

GEARED MOTORS

0.18 kW

4 POLE

N2 R/MIN	i	M2 Nm	Fm	N	Unit Designation	Kg	Motor Size
Output Speed	Ratio	Output Torque	Service Factor	Overhung Load	Column Entry 1 Through 20 Spaces to be filled when entering order	Weight of base mount unit	
165	8.33	10	13.65	4269	K 0 3 3 2 8 . 0 _ M _ _ _ _ . 1 8 A - -	20.5	63
122	11.25	13	11.39	4688	1 1 .		
107	12.8	15	10.5	4882	1 2 .		
95	14.5	17	9.71	5076	1 4 .		
74	18.54	22	8.19	5481	1 8 .		
69	19.98	24	7.77	5606	2 0 .		
54	25.23	30	6.56	5913	2 5 .		
48	28.6	34	5.98	5916	2 8 .		
42	32.68	39	5.46	5917	3 2 .		
38	36.35	43	5.03	5917	3 6 .		
34	40.08	48	4.63	5952	4 0 .		
31	44.11	53	4.21	5957	4 5 .		
27	51.68	62	3.6	5963	5 0 .		
22	62	74	3	6000	6 3 .		
19	72.27	87	2.58	6000	7 1 .		
17	80.3	96	2.33	6000	8 0 .		
14	96.7	116	1.6	6000	1 0 0		
12	110.83	132	1.2	6000	1 1 2		
11	125.96	151	1.03	6000	1 2 5		
11	127.79	147	1.52	6000	K 0 3 5 2 1 2 5 _ M _ _ _ _ . 1 8 A - -	29.5	63
9.4	145.34	167	1.34	6000	1 4 0		
8.3	164.66	190	1.18	6000	1 6 0		
6.5	210.58	243	0.92	6000	2 0 0		
6	226.95	262	0.86	6000	2 5 0		
13	105.69	127	3.3	6000	K 0 4 3 2 1 1 2 _ M _ _ _ _ . 1 8 A - -	26.5	63
11	120.15	144	3.06	6000	1 2 5		
10	134.38	156	2.83	6000	K 0 4 5 2 1 2 5 _ M _ _ _ _ . 1 8 A - -	34.5	63
9.3	147.98	171	2.57	6000	1 4 0		
8	170.21	196	2.25	6000	1 6 0		
6.9	199.9	231	1.9	6000	2 0 0		
5.3	257.59	299	1.48	6000	2 5 0		
4.8	284.33	327	1.35	6000	2 8 0		
4.2	322.4	375	1.18	6000	3 2 0		
3.9	355.03	412	1.07	6000	3 6 0		
3.4	407.03	473	0.93	6000	4 0 0		
3.1	448.23	521	0.85	6000	4 5 0		
3	452.95	530	1.24	7496	K 0 5 5 2 4 5 0 _ M _ _ _ _ . 1 8 A - -	48.5	63
2.7	498.8	584	1.13	7496	5 0 0		
2.4	573.74	671	0.98	7496	5 6 0		
2.2	623.76	730	0.9	7496	6 3 0		
3.1	444.5	522	1.58	8000	K 0 6 5 2 4 5 0 _ M _ _ _ _ . 1 8 A - -	56.5	63
2.8	489.49	576	1.43	8000	5 0 0		
2.4	563.04	662	1.25	8000	5 6 0		
2.2	612.13	719	1.15	8000	6 3 0		
1.9	711.95	835	0.99	8000	7 0 0		
1.7	796.55	931	0.89	8000	8 0 0		
2.9	465.77	551	3.03	15000	K 0 7 5 2 4 5 0 _ M _ _ _ _ . 1 8 A - -	74.5	63
2.7	512.91	607	2.75	15000	5 0 0		
2.3	589.97	698	2.39	15000	5 6 0		
2.1	641.41	758	2.2	15000	6 3 0		
1.9	737.04	870	1.92	15000	7 0 0		
1.6	835.78	984	1.7	15000	8 0 0		
1.5	924	1088	1.53	15000	9 0 0		
1.3	1061.77	1249	1.34	15000	1 0 C		
1.1	1204.01	1413	1.18	15000	1 1 C		
1.1	1267.37	1488	1.12	15000	1 2 C		

0.18 kW

6 POLE

NOTE

Other output speeds are available using 2 and 8 pole motors - Consult Application Engineering

108	8.33	15	9.74	4815	K 0 3 3 2 8 . 0 _ M _ _ _ _ . 1 8 C - -	22.5	71
80	11.25	20	8.18	5271	1 1 .		
70	12.8	23	7.5	5482	1 2 .		
62	14.5	26	6.93	5693	1 4 .		
49	18.54	34	5.83	5915	1 8 .		
45	19.98	36	5.52	5916	2 0 .		
36	25.23	46	4.69	5916	2 5 .		
31	28.6	52	4.26	5914	2 8 .		
28	32.68	60	3.72	5910	3 2 .		
25	36.35	66	3.36	5905	3 6 .		
22	40.08	73	3.04	5965	4 0 .		
20	44.11	81	2.77	5964	4 5 .		
17	51.68	95	2.36	5942	5 0 .		
15	62	113	1.97	5976	6 3 .		
12	72.27	132	1.69	5903	7 1 .		
11	80.3	147	1.53	6000	8 0 .		
9.3	96.7	177	1.05	5923	1 0 0		
7	127.79	226	0.99	6000	K 0 3 5 2 1 2 5 _ M _ _ _ _ . 1 8 C - -	30.5	71
6.2	145.34	257	0.87	6000	1 4 0		

SERIES K

SELECTION TABLES

GEARED MOTORS

0.18 kW

6 POLE

N2 R/MIN	i	M2 Nm	Fm	N	Unit Designation	Kg	Motor Size
Output Speed	Ratio	Output Torque	Service Factor	Overhung Load	Column Entry 1 Through 20 Spaces to be filled when entering order	Weight of base mount unit	
11	80.1	146	3.01	6000	K 0 4 3 2 8 0 . _ M _ _ _ _ . 1 8 C - -	27.5	71
10	93.12	170	2.49	6000	1 0 0		
8.5	105.69	193	2.24	5986	1 1 2		
7.5	120.15	219	2.01	6000	1 2 5		
6.7	134.38	239	1.85	6000	K 0 4 5 2 1 2 5 _ M _ _ _ _ . 1 8 C - -	36.5	71
6.1	147.98	263	1.68	6000	1 4 0		
5.3	170.21	301	1.46	6000	1 6 0		
4.5	199.9	355	1.24	6000	2 0 0		
3.5	257.59	458	0.96	6000	2 5 0		
3.2	284.33	502	0.88	6000	2 8 0		
2	452.95	809	0.81	7496	K 0 5 5 2 4 5 0 _ M _ _ _ _ . 1 8 C - -	50.5	71
2	444.5	797	1.04	8000	K 0 6 5 2 4 5 0 _ M _ _ _ _ . 1 8 C - -	58.5	71
1.8	489.49	879	0.94	8000	5 0 0		
1.6	563.04	1010	0.82	8000	5 6 0		
1.9	465.77	839	1.99	15000	K 0 7 5 2 4 5 0 _ M _ _ _ _ . 1 8 C - -	76.5	71
1.8	512.91	925	1.8	15000	5 0 0		
1.5	589.97	1063	1.57	15000	5 6 0		
1.4	641.41	1155	1.45	15000	6 3 0		
1.2	737.04	1325	1.26	15000	7 0 0		
1.1	835.78	1500	1.11	15000	8 0 0		
0.97	924	1656	1.01	15000	9 0 0		
0.85	1061.77	1901	0.88	15000	1 0 C		

0.25 kW

4 POLE

168	8.33	13	10.04	4233	K 0 3 3 2 8 . 0 _ M _ _ _ _ . 2 5 A - -	22.5	71
124	11.25	18	8.38	4640	1 1 .		
109	12.8	21	7.72	4827	1 2 .		
97	14.5	23	7.14	5013	1 4 .		
76	18.54	30	6.02	5401	1 8 .		
70	19.98	33	5.72	5519	2 0 .		
56	25.23	41	4.83	5812	2 5 .		
49	28.6	47	4.4	5818	2 8 .		
43	32.68	53	4.02	5820	3 2 .		
39	36.35	59	3.7	5822	3 6 .		
35	40.08	65	3.41	5896	4 0 .		
32	44.11	72	3.1	5907	4 5 .		
27	51.68	84	2.65	5921	5 0 .		
23	62	101	2.21	6000	6 3 .		
19	72.27	118	1.9	6000	7 1 .		
17	80.3	131	1.71	6000	8 0 .		
14	96.7	158	1.17	6000	1 0 0		
13	110.83	180	0.88	6000	1 1 2		
11	127.79	200	1.12	6000	K 0 3 5 2 1 2 5 _ M _ _ _ _ . 2 5 A - -	30.5	71
10	145.34	228	0.98	6000	1 4 0		
8.5	164.66	258	0.87	6000	1 6 0		
20	71.09	116	3.8	6000	K 0 4 3 2 7 1 . _ M _ _ _ _ . 2 5 A - -	27.5	71
17	80.1	130	3.38	6000	8 0 .		
15	93.12	152	2.69	6000	1 0 0		
13	105.69	172	2.43	6000	1 1 2		
12	120.15	195	2.25	6000	1 2 5		
10	134.38	212	2.08	6000	K 0 4 5 2 1 2 5 _ M _ _ _ _ . 2 5 A - -	36.5	71
9.5	147.98	233	1.89	6000	1 4 0		
8.2	170.21	266	1.65	6000	1 6 0		
7	199.9	315	1.4	6000	2 0 0		
5.4	257.59	406	1.09	6000	2 5 0		
4.9	284.33	444	0.99	6000	2 8 0		
4.3	322.4	509	0.87	6000	3 2 0		
3.1	452.95	720	0.91	7496	K 0 5 5 2 4 5 0 _ M _ _ _ _ . 2 5 A - -	50.5	71
2.8	498.8	794	0.83	7496	5 0 0		
3.1	444.5	710	1.16	8000	K 0 6 5 2 4 5 0 _ M _ _ _ _ . 2 5 A - -	58.5	71
2.9	489.49	783	1.06	8000	5 0 0		
2.5	563.04	900	0.92	8000	5 6 0		
2.3	612.13	978	0.84	8000	6 3 0		
3	465.77	749	2.23	15000	K 0 7 5 2 4 5 0 _ M _ _ _ _ . 2 5 A - -	76.5	71
2.7	512.91	825	2.02	15000	5 0 0		
2.4	589.97	949	1.76	15000	5 6 0		
2.2	641.41	1031	1.62	15000	6 3 0		
1.9	737.04	1183	1.41	15000	7 0 0		
1.7	835.78	1338	1.25	15000	8 0 0		
1.5	924	1479	1.13	15000	9 0 0		
1.3	1061.77	1698	0.98	15000	1 0 C		
1.2	1204.01	1921	0.87	15000	1 1 C		
1.1	1267.37	2023	0.83	15000	1 2 C		

NOTE

Other output speeds are available using 2 and 8 pole motors - Consult Application Engineering

SERIES K

SELECTION TABLES

GEARED MOTORS

0.25 kW

6 POLE

N2 R/MIN	i	M2 Nm	Fm	N	Unit Designation	Kg	Motor Size
Output Speed	Ratio	Output Torque	Service Factor	Overhung Load	Column Entry 1 Through 20 Spaces to be filled when entering order	Weight of base mount unit	
108	8.33	21	7.01	4764	K 0 3 3 2 8 . 0 _ M _ _ _ _ . 2 5 C - -	22.5	71
80	11.25	28	5.89	5202	1 1 .		
70	12.8	32	5.4	5404	1 2 .		
62	14.5	37	4.99	5604	1 4 .		
49	18.54	47	4.2	5816	1 8 .		
45	19.98	51	3.97	5819	2 0 .		
36	25.23	64	3.38	5819	2 5 .		
31	28.6	73	3.06	5815	2 8 .		
28	32.68	83	2.68	5805	3 2 .		
25	36.35	93	2.42	5794	3 6 .		
22	40.08	102	2.19	5925	4 0 .		
20	44.11	112	1.99	5923	4 5 .		
17	51.68	132	1.7	5876	5 0 .		
15	62	158	1.42	5948	6 3 .		
12	72.27	184	1.22	5791	7 1 .		
11	80.3	204	1.1	6000	8 0 .		
18	49.35	125	3.5	6000	K 0 4 3 2 5 0 . _ M _ _ _ _ . 2 5 C - -	27.5	71
15	59.24	150	2.92	6000	6 3 .		
13	71.09	180	2.44	6000	7 1 .		
11	80.1	203	2.17	6000	8 0 .		
10	93.12	237	1.79	6000	1 0 0		
8.5	105.69	268	1.62	5971	1 1 2		
7.5	120.15	304	1.45	6000	1 2 5		
6.7	134.38	332	1.33	6000	K 0 4 5 2 1 2 5 _ M _ _ _ _ . 2 5 C - -	36.5	71
6.1	147.98	365	1.21	6000	1 4 0		
5.3	170.21	418	1.05	6000	1 6 0		
4.5	199.9	493	0.89	6000	2 0 0		
1.9	465.77	1166	1.43	15000	K 0 7 5 2 4 5 0 _ M _ _ _ _ . 2 5 C - -	76.5	71
1.8	512.91	1285	1.3	15000	5 0 0		
1.5	589.97	1476	1.13	15000	5 6 0		
1.4	641.41	1604	1.04	15000	6 3 0		
1.2	737.04	1841	0.91	15000	7 0 0		
1.1	835.78	2083	0.8	15000	8 0 0		

0.37 kW

4 POLE

168	8.33	20	6.78	4171	K 0 3 3 2 8 . 0 _ M _ _ _ _ . 3 7 A - -	22.5	71
124	11.25	27	5.66	4556	1 1 .		
109	12.8	31	5.22	4732	1 2 .		
97	14.5	35	4.83	4906	1 4 .		
76	18.54	45	4.07	5263	1 8 .		
70	19.98	48	3.86	5372	2 0 .		
56	25.23	61	3.26	5640	2 5 .		
49	28.6	69	2.97	5650	2 8 .		
43	32.68	79	2.71	5655	3 2 .		
39	36.35	88	2.5	5658	3 6 .		
35	40.08	97	2.3	5801	4 0 .		
32	44.11	107	2.09	5821	4 5 .		
27	51.68	125	1.79	5849	5 0 .		
23	62	150	1.49	6000	6 3 .		
19	72.27	175	1.28	6000	7 1 .		
17	80.3	194	1.16	6000	8 0 .		
31	45.39	110	3.94	6000	K 0 4 3 2 4 5 . _ M _ _ _ _ . 3 7 A - -	27.5	71
28	49.35	119	3.68	6000	5 0 .		
24	59.24	143	3.08	6000	6 3 .		
20	71.09	171	2.57	6000	7 1 .		
17	80.1	193	2.28	6000	8 0 .		
15	93.12	225	1.82	6000	1 0 0		
13	105.69	255	1.64	6000	1 1 2		
12	120.15	289	1.52	6000	1 2 5		
10	134.38	313	1.41	6000	K 0 4 5 2 1 2 5 _ M _ _ _ _ . 3 7 A - -	36.5	71
9.5	147.98	345	1.28	6000	1 4 0		
8.2	170.21	394	1.12	6000	1 6 0		
7	199.9	466	0.95	6000	2 0 0		
3	465.77	1108	1.51	15000	K 0 7 5 2 4 5 0 _ M _ _ _ _ . 3 7 A - -	76.5	71
2.7	512.91	1222	1.37	15000	5 0 0		
2.4	589.97	1404	1.19	15000	5 6 0		
2.2	641.41	1526	1.09	15000	6 3 0		
1.9	737.04	1751	0.95	15000	7 0 0		
1.7	835.78	1980	0.84	15000	8 0 0		

NOTE

Other output speeds are available using 2 and 8 pole motors - Consult Application Engineering

SERIES K

SELECTION TABLES

GEARED MOTORS

0.37 kW

6 POLE

N2 R/MIN	i	M2 Nm	Fm	N	Unit Designation	Kg	
Output Speed	Ratio	Output Torque	Service Factor	Overhung Load	Column Entry 1 Through 20 Spaces to be filled when entering order	Weight of base mount unit	Motor Size
110	8.33	30	4.84	4676	K 0 3 3 2 8 . 0 _ M _ _ _ _ . 3 7 C - -	25.5	80A
82	11.25	41	4.07	5085	1 1 .		
72	12.8	47	3.73	5269	1 2 .		
63	14.5	53	3.44	5451	1 4 .		
50	18.54	68	2.9	5647	1 8 .		
46	19.98	74	2.75	5653	2 0 .		
36	25.23	93	2.33	5653	2 5 .		
32	28.6	106	2.12	5645	2 8 .		
28	32.68	121	1.85	5625	3 2 .		
25	36.35	134	1.67	5604	3 6 .		
23	40.08	148	1.51	5857	4 0 .		
21	44.11	163	1.38	5853	4 5 .		
18	51.68	191	1.18	5761	5 0 .		
15	62	229	0.98	5901	6 3 .		
13	72.27	267	0.84	5598	7 1 .		
29	31.54	116	3.7	6000	K 0 4 3 2 3 2 . _ M _ _ _ _ . 3 7 C - -	31.5	80A
26	35.83	131	3.34	6000	3 6 .		
23	39.46	145	3.03	6000	4 0 .		
20	45.39	168	2.62	6000	4 5 .		
19	49.35	182	2.42	6000	5 0 .		
16	59.24	218	2.02	6000	6 3 .		
13	71.09	261	1.69	5990	7 1 .		
11	80.1	294	1.5	6000	8 0 .		
10	93.12	343	1.24	6000	1 0 0		
8.7	105.69	388	1.12	5944	1 1 2		
7.7	120.15	441	1	6000	1 2 5		
6.8	134.38	480	0.92	6000	K 0 4 5 2 1 2 5 _ M _ _ _ _ . 3 7 C - -	39.5	80A
6.2	147.98	529	0.83	6000	1 4 0		
12	79.77	294	2.24	8000	K 0 5 3 2 8 0 . _ M _ _ _ _ . 3 7 C - -	40.5	80A
9.4	97.76	360	1.83	8000	1 0 0		
8.4	108.96	401	1.64	8000	1 1 2		
7.5	122.2	448	1.35	8000	1 2 5		
13	71.49	263	3.13	8000	K 0 6 3 2 7 1 . _ M _ _ _ _ . 3 7 C - -	48.5	80A
12	78.28	290	2.85	8000	8 0 .		
10	95.93	353	2.34	8000	1 0 0		
8.6	106.93	393	2.1	8000	1 1 2		
7.7	119.92	439	1.35	8000	1 2 5		
2	465.77	1688	0.99	15000	K 0 7 5 2 4 5 0 _ M _ _ _ _ . 3 7 C - -	79.5	80A
1.8	512.91	1861	0.9	15000	5 0 0		
2	462.28	1672	1.62	15674	K 0 8 5 2 4 5 0 _ M _ _ _ _ . 3 7 C - -	148.5	80A
1.8	505.9	1829	1.48	15674	5 0 0		
1.7	537.67	1944	1.39	15674	5 6 0		
1.4	641.16	2317	1.17	15674	6 3 0		
1.2	759.86	2743	0.99	15674	7 0 0		
1.1	811.29	2927	0.93	15674	8 0 0		
1	887.84	3203	0.85	15674	9 0 0		
1.6	562.75	2039	1.85	34000	K 0 9 5 1 5 6 0 _ M _ _ _ _ . 3 7 C - -	206.5	80A
1.4	654.52	2370	1.59	34000	6 3 0		
1.3	727.17	2630	1.44	34000	7 0 0		
1.2	788.65	2853	1.48	34000	8 0 0		
0.98	940.44	3400	1.24	34000	9 0 0		
0.9	1027.68	3710	1.02	34000	1 0 C		
0.83	1114.56	4025	1.05	34000	1 1 C		
0.77	1190	4295	0.98	34000	1 2 C		

0.55 kW

4 POLE

NOTE
Other output speeds are available using 2 and 8 pole motors - Consult Application Engineering

171	8.33	29	4.63	4078	K 0 3 3 2 8 . 0 _ M _ _ _ _ . 5 5 A - -	25.5	80A
126	11.25	40	3.86	4432	1 1 .		
111	12.8	45	3.56	4590	1 2 .		
98	14.5	51	3.29	4745	1 4 .		
77	18.54	66	2.78	5057	1 8 .		
71	19.98	71	2.64	5150	2 0 .		
56	25.23	90	2.23	5381	2 5 .		
50	28.6	102	2.03	5398	2 8 .		
43	32.68	116	1.85	5407	3 2 .		
39	36.35	129	1.71	5412	3 6 .		
35	40.08	143	1.57	5658	4 0 .		
32	44.11	157	1.43	5692	4 5 .		
27	51.68	184	1.22	5740	5 0 .		
23	62	220	1.02	6000	6 3 .		
20	72.27	256	0.88	6000	7 1 .		

SERIES K

SELECTION TABLES

GEARED MOTORS

0.55 kW

4 POLE

N2 R/MIN	i	M2 Nm	Fm	N	Unit Designation	Kg	Motor Size
Output Speed	Ratio	Output Torque	Service Factor	Overhung Load	Column Entry 1 Through 20 Spaces to be filled when entering order	Weight of base mount unit	
51	27.76	99	3.85	6000	K 0 4 3 2 2 8 . _ M _ _ _ _ . 5 5 A - -	31.5	80A
45	31.54	112	3.51	6000	3 2 .		
40	35.83	127	3.28	6000	3 6 .		
36	39.46	140	2.97	6000	4 0 .		
31	45.39	162	2.69	6000	4 5 .		
29	49.35	175	2.51	6000	5 0 .		
24	59.24	209	2.1	6000	6 3 .		
20	71.09	251	1.75	6000	7 1 .		
18	80.1	283	1.56	6000	8 0 .		
15	93.12	330	1.24	6000	1 0 0		
13	105.69	374	1.12	6000	1 1 2		
12	120.15	424	1.04	6000	1 2 5		
11	134.38	460	0.96	6000	K 0 4 5 2 1 2 5 _ M _ _ _ _ . 5 5 A - -	39.5	80A
10	147.98	505	0.87	6000	1 4 0		
19	72.85	258	2.55	8000	K 0 5 3 2 7 1 . _ M _ _ _ _ . 5 5 A - -	40.5	80A
18	79.77	282	2.33	8000	8 0 .		
15	97.76	345	1.91	8000	1 0 0		
13	108.96	386	1.71	8000	1 1 2		
12	122.2	432	1.41	8000	1 2 5		
12	118.4	406	1.62	7496	K 0 5 5 2 1 2 5 _ M _ _ _ _ . 5 5 A - -	53.5	80A
10	142.79	492	1.34	7496	1 4 0		
9	157.35	542	1.21	7496	1 6 0		
6.8	207.81	713	0.92	7496	2 0 0		
23	60.62	216	3.83	8000	K 0 6 3 2 6 3 . _ M _ _ _ _ . 5 5 A - -	48.5	80A
20	71.49	253	3.26	8000	7 1 .		
18	78.28	278	2.97	8000	8 0 .		
15	95.93	341	2.42	8000	1 0 0		
13	106.93	377	2.19	8000	1 1 2		
12	119.92	423	1.41	8000	1 2 5		
12	116.19	401	2.06	8000	K 0 6 5 2 1 2 5 _ M _ _ _ _ . 5 5 A - -	61.5	80A
10	140.12	485	1.7	8000	1 4 0		
9.2	154.41	535	1.54	8000	1 6 0		
7	203.93	704	1.17	8000	2 0 0		
5.5	259.02	895	0.92	8000	2 5 0		
4.8	294.26	1017	0.81	8000	2 8 0		
13	113.5	401	3.99	15000	K 0 7 3 2 1 1 2 _ M _ _ _ _ . 5 5 A - -	67.5	80A
11	126.11	442	3.12	15000	1 2 5		
12	120.29	420	3.98	15000	K 0 7 5 2 1 2 5 _ M _ _ _ _ . 5 5 A - -	79.5	80A
11	133.48	467	3.57	15000	1 4 0		
10	147.09	515	3.24	15000	1 6 0		
6.7	211.12	737	2.27	15000	2 0 0		
6.1	233.36	816	2.05	15000	2 5 0		
5.4	265.1	927	1.8	15000	2 8 0		
4.7	304.63	1063	1.57	15000	3 2 0		
3.8	373.86	1305	1.28	15000	3 6 0		
3.4	414.65	1447	1.15	15000	4 0 0		
3	465.77	1625	1.03	15000	4 5 0		
2.8	512.91	1791	0.93	15000	5 0 0		
2.4	589.97	2058	0.81	15000	5 6 0		
3.1	462.28	1605	1.69	15674	K 0 8 5 2 4 5 0 _ M _ _ _ _ . 5 5 A - -	148.5	80A
2.8	505.9	1756	1.54	15674	5 0 0		
2.6	537.67	1867	1.45	15674	5 6 0		
2.2	641.16	2226	1.22	15674	6 3 0		
1.9	759.86	2637	1.03	15674	7 0 0		
1.8	811.29	2815	0.96	15674	8 0 0		
1.6	887.84	3079	0.88	15674	9 0 0		
2.5	562.75	1959	1.93	34000	K 0 9 5 1 5 6 0 _ M _ _ _ _ . 5 5 A - -	206.5	80A
2.2	654.52	2278	1.66	34000	6 3 0		
2	727.17	2526	1.49	34000	7 0 0		
1.8	788.65	2742	1.54	34000	8 0 0		
1.5	940.44	3269	1.29	34000	9 0 0		
1.4	1027.68	3567	1.06	34000	1 0 C		
1.3	1114.56	3871	1.09	34000	1 1 C		
1.2	1190	4132	1.02	34000	1 2 C		
0.96	1476.68	5121	0.82	34000	1 4 C		

NOTE

Other output speeds are available using 2 and 8 pole motors - Consult Application Engineering

SERIES K

SELECTION TABLES

GEARED MOTORS

0.55 kW

6 POLE

N2 R/MIN	i	M2 Nm	Fm	N	Unit Designation	Kg	Motor Size
Output Speed	Ratio	Output Torque	Service Factor	Overhung Load	Column Entry 1 Through 20 Spaces to be filled when entering order	Weight of base mount unit	
110	8.33	46	3.26	4544	K 0 3 3 2 8 . 0 _ M _ _ _ _ . 5 5 C - -	27	80B
82	11.25	62	2.74	4908	1 1 .		
72	12.8	70	2.51	5067	1 2 .		
63	14.5	79	2.32	5221	1 4 .		
50	18.54	102	1.95	5394	1 8 .		
46	19.98	110	1.85	5403	2 0 .		
36	25.23	139	1.57	5403	2 5 .		
32	28.6	158	1.42	5390	2 8 .		
28	32.68	180	1.25	5355	3 2 .		
25	36.35	200	1.12	5319	3 6 .		
23	40.08	221	1.02	5754	4 0 .		
21	44.11	243	0.93	5747	4 5 .		
51	17.95	99	3.64	6000	K 0 4 3 2 1 8 . _ M _ _ _ _ . 5 5 C - -	33	80B
45	20.4	112	3.35	6000	2 0 .		
37	25.03	137	2.91	6000	2 5 .		
33	27.76	153	2.68	6000	2 8 .		
29	31.54	173	2.49	6000	3 2 .		
26	35.83	196	2.25	6000	3 6 .		
23	39.46	216	2.04	6000	4 0 .		
20	45.39	250	1.76	6000	4 5 .		
19	49.35	270	1.63	6000	5 0 .		
16	59.24	324	1.36	6000	6 3 .		
13	71.09	388	1.13	5975	7 1 .		
11	80.1	437	1.01	6000	8 0 .		
10	93.12	510	0.83	6000	1 0 0		
15	61.78	340	1.93	8000	K 0 5 3 2 6 3 . _ M _ _ _ _ . 5 5 C - -	42	80B
13	72.85	400	1.65	8000	7 1 .		
12	79.77	437	1.51	7321	8 0 .		
9.4	97.76	535	1.23	7176	1 0 0		
8.4	108.96	596	1.1	6954	1 1 2		
7.5	122.2	667	0.91	6976	1 2 5		
7.8	118.4	631	1.04	7496	K 0 5 5 2 1 2 5 _ M _ _ _ _ . 5 5 C - -	55	80B
6.4	142.79	764	0.86	7496	1 4 0		
20	45.76	252	3.28	8000	K 0 6 3 2 4 5 . _ M _ _ _ _ . 5 5 C - -	50	80B
19	48.86	269	3.07	8000	5 0 .		
15	60.62	334	2.47	8000	6 3 .		
13	71.49	392	2.11	7928	7 1 .		
12	78.28	431	1.92	8000	8 0 .		
10	95.93	525	1.57	8000	1 0 0		
8.6	106.93	585	1.41	7858	1 1 2		
7.7	119.92	654	0.91	8000	1 2 5		
7.9	116.19	623	1.33	8000	K 0 6 5 2 1 2 5 _ M _ _ _ _ . 5 5 C - -	63	80B
6.6	140.12	753	1.1	8000	1 4 0		
6	154.41	830	1	8000	1 6 0		
9.3	98.65	536	2.98	15000	K 0 7 3 2 1 0 0 _ M _ _ _ _ . 5 5 C - -	69	80B
8.1	113.5	620	2.58	15000	1 1 2		
7.3	126.11	682	2.02	15000	1 2 5		
7.6	120.29	650	2.57	15000	K 0 7 5 2 1 2 5 _ M _ _ _ _ . 5 5 C - -	81	80B
6.9	133.48	723	2.31	15000	1 4 0		
6.3	147.09	797	2.09	15000	1 6 0		
4.4	211.12	1141	1.46	15000	2 0 0		
3.9	233.36	1262	1.32	15000	2 5 0		
3.5	265.1	1434	1.16	15000	2 8 0		
3	304.63	1645	1.02	15000	3 2 0		
2.5	373.86	2018	0.83	15000	3 6 0		
2	462.28	2486	1.09	15674	K 0 8 5 2 4 5 0 _ M _ _ _ _ . 5 5 C - -	150	80B
1.8	505.9	2719	1	15674	5 0 0		
1.7	537.67	2890	0.94	15674	5 6 0		
1.6	562.75	3031	1.25	34000	K 0 9 5 1 5 6 0 _ M _ _ _ _ . 5 5 C - -	208	80B
1.4	654.52	3524	1.07	34000	6 3 0		
1.3	727.17	3909	0.97	34000	7 0 0		
1.2	788.65	4242	0.99	34000	8 0 0		
0.98	940.44	5054	0.83	34000	9 0 0		
1.8	514.73	2775	2.59	43100	K 1 0 5 1 5 0 0 _ M _ _ _ _ . 5 5 C - -	332	80B
1.6	566.2	3051	2.35	43100	5 6 0		
1.4	650.62	3505	2.05	43100	6 3 0		
1.3	722.98	3888	1.85	43100	7 0 0		
1.2	783.15	4209	1.71	43100	8 0 0		
1	904.27	4859	1.48	43100	9 0 0		
0.94	979.53	5259	1.37	43100	1 0 C		
0.79	1170.88	6283	1.14	43100	1 1 C		
0.73	1268.32	6799	1.06	43100	1 2 C		
0.63	1470.48	7872	0.91	43100	1 4 C		
0.56	1634.03	8737	0.82	43100	1 6 C		
1.6	584.22	3150	3.84	61368	K 1 2 5 1 5 6 0 _ M _ _ _ _ . 5 5 C - -	492	80B
1.4	671.32	3618	3.34	61368	6 3 0		
1.2	756.72	4076	2.97	61368	7 0 0		
1.1	808.78	4353	2.85	61293	8 0 0		
0.97	946.46	5093	2.37	61368	9 0 0		
0.91	1011.58	5439	2.28	61293	1 0 C		
0.81	1140.25	6128	2.03	61293	1 1 C		
0.75	1225.51	6584	1.84	61368	1 2 C		
0.61	1518.59	8141	1.53	61293	1 4 C		
0.54	1711.76	9174	1.35	61293	1 6 C		
0.51	1811.28	9693	1.28	61293	1 8 C		
0.45	2041.68	10923	1.14	61293	2 0 C		
0.41	2235.86	11949	1.04	61293	2 2 C		
0.34	2683.03	14299	0.87	61293	2 5 C		
0.32	2887.22	15351	0.81	61293	2 8 C		

NOTE
Other output speeds are available using 2 and 8 pole motors - Consult Application Engineering

SERIES K

SELECTION TABLES

GEARED MOTORS

0.75 kW

4 POLE

N2 R/MIN	i	M2 Nm	Fm	N	Unit Designation	Kg	Motor Size
Output Speed	Ratio	Output Torque	Service Factor	Overhung Load	Column Entry 1 Through 20 Spaces to be filled when entering order	Weight of base mount unit	
170	8.33	40	3.38	3975	K 0 3 3 2 8 . 0 _ M _ _ _ _ . 7 5 A - -	25.5	80A
126	11.25	54	2.82	4293	1 1 .		
111	12.8	62	2.6	4433	1 2 .		
98	14.5	71	2.41	4566	1 4 .		
76	18.54	90	2.03	4828	1 8 .		
71	19.98	98	1.93	4903	2 0 .		
56	25.23	123	1.63	5093	2 5 .		
49	28.6	140	1.48	5119	2 8 .		
43	32.68	158	1.35	5132	3 2 .		
39	36.35	177	1.25	5138	3 6 .		
35	40.08	195	1.15	5500	4 0 .		
32	44.11	215	1.04	5550	4 5 .		
27	51.68	252	0.89	5620	5 0 .		
79	17.95	87	3.81	6000	K 0 4 3 2 1 8 . _ M _ _ _ _ . 7 5 A - -	31.5	80A
69	20.4	99	3.49	6000	2 0 .		
57	25.03	122	3.03	5945	2 5 .		
51	27.76	135	2.81	5944	2 8 .		
45	31.54	153	2.56	5939	3 2 .		
39	35.83	175	2.39	6000	3 6 .		
36	39.46	192	2.17	6000	4 0 .		
31	45.39	221	1.96	6000	4 5 .		
29	49.35	240	1.83	6000	5 0 .		
24	59.24	287	1.54	6000	6 3 .		
20	71.09	344	1.28	6000	7 1 .		
18	80.1	387	1.14	6000	8 0 .		
15	93.12	452	0.91	6000	1 0 0		
13	105.69	512	0.82	6000	1 1 2		
43	32.99	160	3.77	7830	K 0 5 3 2 3 2 . _ M _ _ _ _ . 7 5 A - -	40.5	80A
38	36.91	180	3.54	8000	3 6 .		
36	39.34	192	3.29	8000	4 0 .		
30	46.63	227	2.89	8000	4 5 .		
28	49.78	243	2.71	8000	5 0 .		
23	61.78	301	2.19	8000	6 3 .		
19	72.85	354	1.86	7667	7 1 .		
18	79.77	386	1.7	7637	8 0 .		
14	97.76	473	1.39	7760	1 0 0		
13	108.96	528	1.25	7541	1 1 2		
12	122.2	591	1.03	8000	1 2 5		
12	118.4	555	1.19	7496	K 0 5 5 2 1 2 5 _ M _ _ _ _ . 7 5 A - -	53.5	80A
10	142.79	673	0.98	7496	1 4 0		
9	157.35	742	0.89	7496	1 6 0		
31	45.76	223	3.71	8000	K 0 6 3 2 4 5 . _ M _ _ _ _ . 7 5 A - -	48.5	80A
29	48.86	238	3.47	8000	5 0 .		
23	60.62	295	2.8	8000	6 3 .		
20	71.49	347	2.38	8000	7 1 .		
18	78.28	380	2.17	8000	8 0 .		
15	95.93	467	1.77	8000	1 0 0		
13	106.93	516	1.6	8000	1 1 2		
12	119.92	579	1.03	8000	1 2 5		
12	116.19	549	1.51	8000	K 0 6 5 2 1 2 5 _ M _ _ _ _ . 7 5 A - -	61.5	80A
10	140.12	665	1.24	8000	1 4 0		
9.2	154.41	732	1.13	8000	1 6 0		
6.9	203.93	964	0.86	8000	2 0 0		
14	98.65	476	3.36	15000	K 0 7 3 2 1 0 0 _ M _ _ _ _ . 7 5 A - -	67.5	80A
12	113.5	548	2.91	15000	1 1 2		
11	126.11	606	2.28	15000	1 2 5		
12	120.29	574	2.91	15000	K 0 7 5 2 1 2 5 _ M _ _ _ _ . 7 5 A - -	79.5	80A
11	133.48	640	2.61	15000	1 4 0		
10	147.09	705	2.37	15000	1 6 0		
6.7	211.12	1009	1.66	15000	2 0 0		
6.1	233.36	1117	1.49	15000	2 5 0		
5.3	265.1	1269	1.32	15000	2 8 0		
4.6	304.63	1455	1.15	15000	3 2 0		
3.8	373.86	1786	0.94	15000	3 6 0		
3.4	414.65	1980	0.84	15000	4 0 0		
3.1	462.28	2197	1.23	15674	K 0 8 5 2 4 5 0 _ M _ _ _ _ . 7 5 A - -	148.5	80A
2.8	505.9	2403	1.13	15674	5 0 0		
2.6	537.67	2555	1.06	15674	5 6 0		
2.2	641.16	3047	0.89	15674	6 3 0		
2.5	562.75	2681	1.41	34000	K 0 9 5 1 5 6 0 _ M _ _ _ _ . 7 5 A - -	206.5	80A
2.2	654.52	3118	1.21	34000	6 3 0		
1.9	727.17	3457	1.09	34000	7 0 0		
1.8	788.65	3752	1.12	34000	8 0 0		
1.5	940.44	4473	0.94	34000	9 0 0		

NOTE

Other output speeds are available using 2 and 8 pole motors - Consult Application Engineering

SERIES K

SELECTION TABLES

GEARED MOTORS

0.75 kW

4 POLE

N2 R/MIN	i	M2 Nm	Fm	N	Unit Designation	Kg	Motor Size		
Output Speed	Ratio	Output Torque	Service Factor	Overhung Load	Column Entry 1 Through 20 Spaces to be filled when entering order	Weight of base mount unit			
2.7	514.73	2453	2.93	43100	K 1 0 5 1 5 0 0 _ M _ _ _ _ . 7 5 A - -	330.5	80A		
2.5	566.2	2698	2.66	43100	5 6 0				
2.2	650.62	3100	2.32	43100	6 3 0				
2	722.98	3438	2.09	43100	7 0 0				
1.8	783.15	3721	1.93	43100	8 0 0				
1.6	904.27	4299	1.67	43100	9 0 0				
1.4	979.53	4653	1.54	43100	1 0 C				
1.2	1170.88	5562	1.29	43100	1 1 C				
1.1	1268.32	6019	1.19	43100	1 2 C				
0.96	1470.48	6973	1.03	43100	1 4 C				
0.87	1634.03	7736	0.93	43100	1 6 C				
0.81	1753.89	8307	0.86	43100	1 8 C				
2.1	671.32	3203	3.77	61368	K 1 2 5 1 6 3 0 _ M _ _ _ _ . 7 5 A - -			490.5	80A
1.9	756.72	3608	3.35	61368	7 0 0				
1.7	808.78	3854	3.22	61293	8 0 0				
1.5	946.46	4510	2.68	61368	9 0 0				
1.4	1011.58	4817	2.58	61293	1 0 C				
1.2	1140.25	5425	2.29	61293	1 1 C				
1.2	1225.51	5833	2.07	61368	1 2 C				
0.93	1518.59	7215	1.72	61293	1 4 C				
0.83	1711.76	8128	1.53	61293	1 6 C				
0.78	1811.28	8594	1.45	61293	1 8 C				
0.69	2041.68	9683	1.28	61293	2 0 C				
0.63	2235.86	10595	1.17	61293	2 2 C				
0.53	2683.03	12685	0.98	61293	2 5 C				
0.49	2887.22	13594	0.91	61293	2 8 C				

0.75 kW

6 POLE

110	8.33	62	2.39	4397	K 0 3 3 2 8 . 0 _ M _ _ _ _ . 7 5 C - -	30.5	90S		
82	11.25	84	2.01	4712	1 1 .				
72	12.8	96	1.84	4842	1 2 .				
63	14.5	108	1.7	4966	1 4 .				
50	18.54	139	1.43	5112	1 8 .				
46	19.98	150	1.35	5125	2 0 .				
36	25.23	189	1.15	5125	2 5 .				
32	28.6	215	1.04	5106	2 8 .				
28	32.68	246	0.91	5055	3 2 .				
25	36.35	273	0.82	5003	3 6 .				
81	11.3	85	3.63	6000	K 0 4 3 2 1 1 . _ M _ _ _ _ . 7 5 C - -			35.5	90S
74	12.45	93	3.42	6000	1 2 .				
65	14.14	106	3.14	6000	1 4 .				
51	17.95	135	2.67	6000	1 8 .				
45	20.4	153	2.45	6000	2 0 .				
37	25.03	187	2.13	6000	2 5 .				
33	27.76	209	1.97	6000	2 8 .				
29	31.54	236	1.83	6000	3 2 .				
26	35.83	267	1.65	6000	3 6 .				
23	39.46	294	1.49	6000	4 0 .				
20	45.39	341	1.29	6000	4 5 .				
19	49.35	369	1.19	6000	5 0 .				
16	59.24	443	1	6000	6 3 .				
13	71.09	530	0.83	5958	7 1 .				
32	28.37	213	2.96	8000	K 0 5 3 2 2 8 . _ M _ _ _ _ . 7 5 C - -	45.5	90S		
28	32.99	247	2.66	8000	3 2 .				
25	36.91	277	2.38	8000	3 6 .				
23	39.34	296	2.22	8000	4 0 .				
20	46.63	350	1.88	8000	4 5 .				
18	49.78	373	1.76	8000	5 0 .				
15	61.78	464	1.42	7520	6 3 .				
13	72.85	545	1.21	7265	7 1 .				
12	79.77	596	1.1	6567	8 0 .				
9.4	97.76	730	0.9	6261	1 0 0				
8.4	108.96	813	0.81	5792	1 1 2				
33	27.84	209	3.95	8000	K 0 6 3 2 2 8 . _ M _ _ _ _ . 7 5 C - -			53.5	90S
28	32.38	243	3.4	8000	3 2 .				
25	36.22	271	3.04	8000	3 6 .				
24	38.61	290	2.85	8000	4 0 .				
20	45.76	344	2.4	8000	4 5 .				
19	48.86	367	2.25	8000	5 0 .				
15	60.62	455	1.81	8000	6 3 .				
13	71.49	534	1.55	7848	7 1 .				
12	78.28	588	1.41	8000	8 0 .				
10	95.93	716	1.15	8000	1 0 0				
8.6	106.93	798	1.04	7700	1 1 2				
7.9	116.19	849	0.97	8000	K 0 6 5 2 1 2 5 _ M _ _ _ _ . 7 5 C - -	66.5	90S		
6.6	140.12	1027	0.8	8000	1 4 0				
12	75.07	559	2.86	15000	K 0 7 3 2 7 1 . _ M _ _ _ _ . 7 5 C - -	72.5	90S		
11	82.21	613	2.61	15000	8 0 .				
9.3	98.65	732	2.18	14487	1 0 0				
8.1	113.5	846	1.89	14539	1 1 2				
7.3	126.11	931	1.48	14894	1 2 5				

NOTE
Other output speeds are available using 2 and 8 pole motors - Consult Application Engineering

SERIES K SELECTION TABLES GEARED MOTORS

0.75 kW

6 POLE

N2 R/MIN	i	M2 Nm	Fm	N	Unit Designation	Kg	
Output Speed	Ratio	Output Torque	Service Factor	Overhung Load	Column Entry 1 Through 20 Spaces to be filled when entering order	Weight of base mount unit	Motor Size
7.6	120.29	886	1.88	15000	K 0 7 5 2 1 2 5 _ M _ _ _ _ . 7 5 C - -	84.5	90S
6.9	133.48	986	1.69	15000	1 4 0		
6.3	147.09	1087	1.54	15000	1 6 0		
4.4	211.12	1556	1.07	15000	2 0 0		
3.9	233.36	1722	0.97	15000	2 5 0		
3.5	265.1	1955	0.85	15000	2 8 0		
8.6	107.1	797	3.36	21500	K 0 8 3 2 1 1 2 _ M _ _ _ _ . 7 5 C - -	127.5	90S
7.5	123.33	915	2.93	21500	1 2 5		
1.6	562.75	4134	0.91	34000	K 0 9 5 1 5 6 0 _ M _ _ _ _ . 7 5 C - -	211.5	90S
1.8	514.73	3784	1.9	43100	K 1 0 5 1 5 0 0 _ M _ _ _ _ . 7 5 C - -	335.5	90S
1.6	566.2	4161	1.73	43100	5 6 0		
1.4	650.62	4779	1.5	43100	6 3 0		
1.3	722.98	5303	1.36	43100	7 0 0		
1.2	783.15	5739	1.25	43100	8 0 0		
1	904.27	6627	1.08	43100	9 0 0		
0.94	979.53	7172	1	43100	1 0 C		
0.79	1170.88	8568	0.84	43100	1 1 C		
1.7	531.11	3907	3.1	61368	K 1 2 5 1 5 0 0 _ M _ _ _ _ . 7 5 C - -	495.5	90S
1.6	584.22	4296	2.81	61368	5 6 0		
1.4	671.32	4934	2.45	61368	6 3 0		
1.2	756.72	5559	2.18	61368	7 0 0		
1.1	808.78	5937	2.09	61293	8 0 0		
0.97	946.46	6946	1.74	61368	9 0 0		
0.91	1011.58	7417	1.68	61293	1 0 C		
0.81	1140.25	8357	1.49	61293	1 1 C		
0.75	1225.51	8979	1.35	61368	1 2 C		
0.61	1518.59	11101	1.12	61293	1 4 C		
0.54	1711.76	12510	0.99	61293	1 6 C		
0.51	1811.28	13217	0.94	61293	1 8 C		
0.45	2041.68	14895	0.83	61293	2 0 C		

1.1 kW

4 POLE

169	8.33	59	2.3	3795	K 0 3 3 2 8 . 0 _ M _ _ _ _ . 1 . 1 A - -	30.5	90S
125	11.25	80	1.92	4051	1 1 .		
110	12.8	92	1.77	4157	1 2 .		
97	14.5	104	1.64	4253	1 4 .		
76	18.54	133	1.38	4427	1 8 .		
71	19.98	144	1.31	4472	2 0 .		
56	25.23	181	1.11	4590	2 5 .		
49	28.6	206	1.01	4630	2 8 .		
43	32.68	233	0.92	4650	3 2 .		
39	36.35	260	0.85	4660	3 6 .		
125	11.3	81	3.5	5740	K 0 4 3 2 1 1 . _ M _ _ _ _ . 1 . 1 A - -	35.5	90S
113	12.45	89	3.3	5890	1 2 .		
100	14.14	101	3.04	6000	1 4 .		
79	17.95	128	2.59	5867	1 8 .		
69	20.4	146	2.37	5881	2 0 .		
56	25.03	179	2.06	5850	2 5 .		
51	27.76	199	1.91	5846	2 8 .		
45	31.54	226	1.74	5833	3 2 .		
39	35.83	257	1.63	6000	3 6 .		
36	39.46	283	1.48	6000	4 0 .		
31	45.39	326	1.33	6000	4 5 .		
29	49.35	353	1.25	6000	5 0 .		
24	59.24	422	1.04	6000	6 3 .		
20	71.09	507	0.87	6000	7 1 .		
50	28.37	203	2.86	7070	K 0 5 3 2 2 8 . _ M _ _ _ _ . 1 . 1 A - -	45.5	90S
43	32.99	236	2.56	7262	3 2 .		
38	36.91	265	2.4	7370	3 6 .		
36	39.34	283	2.24	7345	4 0 .		
30	46.63	335	1.96	7295	4 5 .		
28	49.78	357	1.84	7266	5 0 .		
23	61.78	443	1.49	7346	6 3 .		
19	72.85	521	1.26	7085	7 1 .		
18	79.77	569	1.16	7004	8 0 .		
14	97.76	696	0.95	7340	1 0 0		
13	108.96	778	0.85	6740	1 1 2		
12	118.4	818	0.81	7496	K 0 5 5 2 1 2 5 _ M _ _ _ _ . 1 . 1 A - -	58.5	90S
44	32.38	232	3.55	7864	K 0 6 3 2 3 2 . _ M _ _ _ _ . 1 . 1 A - -	53.5	90S
39	36.22	260	3.17	7844	3 6 .		
37	38.61	277	2.98	7830	4 0 .		
31	45.76	328	2.52	7987	4 5 .		
29	48.86	350	2.36	7973	5 0 .		
23	60.62	435	1.9	8000	6 3 .		
20	71.49	511	1.62	8000	7 1 .		
18	78.28	560	1.48	8000	8 0 .		
15	95.93	687	1.2	8000	1 0 0		
13	106.93	760	1.09	8000	1 1 2		
12	116.19	808	1.02	8000	K 0 6 5 2 1 2 5 _ M _ _ _ _ . 1 . 1 A - -	66.5	90S
10	140.12	978	0.84	8000	1 4 0		
22	62.94	449	3.56	15000	K 0 7 3 2 6 3 . _ M _ _ _ _ . 1 . 1 A - -	72.5	90S
19	75.07	535	2.99	15000	7 1 .		
17	82.21	585	2.73	15000	8 0 .		
14	98.65	701	2.28	14720	1 0 0		
12	113.5	808	1.98	15000	1 1 2		
11	126.11	892	1.55	15000	1 2 5		

NOTE

Other output speeds are available using 2 and 8 pole motors - Consult Application Engineering

SERIES K

SELECTION TABLES

GEARED MOTORS

1.1 kW

4 POLE

N2 R/MIN	i	M2 Nm	Fm	N	Unit Designation	Kg	
Output Speed	Ratio	Output Torque	Service Factor	Overhung Load	Column Entry 1 Through 20 Spaces to be filled when entering order	Weight of base mount unit	Motor Size
12	120.29	846	1.97	15000	K 0 7 5 2 1 2 5 _ M _ _ _ _ 1 . 1 A - -	84.5	90S
11	133.48	942	1.77	15000	1 4 0		
10	147.09	1038	1.61	15000	1 6 0		
6.7	211.12	1485	1.12	15000	2 0 0		
6	233.36	1644	1.02	15000	2 5 0		
5.3	265.1	1868	0.89	15000	2 8 0		
14	98.08	700	3.83	21500	K 0 8 3 2 1 0 0 _ M _ _ _ _ 1 . 1 A - -	127.5	90S
13	107.1	763	3.51	21500	1 1 2		
11	123.33	876	3.06	21500	1 2 5		
3.1	462.28	3234	0.84	15674	K 0 8 5 2 4 5 0 _ M _ _ _ _ 1 . 1 A - -	153.5	90S
2.5	562.75	3946	0.96	34000	K 0 9 5 1 5 6 0 _ M _ _ _ _ 1 . 1 A - -	211.5	90S
2.2	654.52	4589	0.82	34000	6 3 0		
2.7	514.73	3611	1.99	43100	K 1 0 5 1 5 0 0 _ M _ _ _ _ 1 . 1 A - -	335.5	90S
2.5	566.2	3972	1.81	43100	5 6 0		
2.2	650.62	4563	1.57	43100	6 3 0		
2	722.98	5061	1.42	43100	7 0 0		
1.8	783.15	5477	1.31	43100	8 0 0		
1.6	904.27	6328	1.14	43100	9 0 0		
1.4	979.53	6848	1.05	43100	1 0 C		
1.2	1170.88	8187	0.88	43100	1 1 C		
1.1	1268.32	8860	0.81	43100	1 2 C		
2.7	531.11	3733	3.24	61368	K 1 2 5 1 5 0 0 _ M _ _ _ _ 1 . 1 A - -	495.5	90S
2.4	584.22	4105	2.95	61368	5 6 0		
2.1	671.32	4715	2.56	61368	6 3 0		
1.9	756.72	5311	2.28	61368	7 0 0		
1.7	808.78	5672	2.19	61293	8 0 0		
1.5	946.46	6638	1.82	61368	9 0 0		
1.4	1011.58	7090	1.75	61293	1 0 C		
1.2	1140.25	7985	1.56	61293	1 1 C		
1.2	1225.51	8586	1.41	61368	1 2 C		
0.93	1518.59	10620	1.17	61293	1 4 C		
0.82	1711.76	11964	1.04	61293	1 6 C		
0.78	1811.28	12650	0.98	61293	1 8 C		
0.69	2041.68	14252	0.87	61293	2 0 C		

1.1 kW

6 POLE

111	8.33	91	1.64	4140	K 0 3 3 2 8 . 0 _ M _ _ _ _ 1 . 1 C - -	31.5	90L
82	11.25	123	1.38	4370	1 1 .		
72	12.8	140	1.26	4450	1 2 .		
64	14.5	158	1.17	4520	1 4 .		
50	18.54	203	0.98	4620	1 8 .		
46	19.98	219	0.93	4640	2 0 .		
115	8.05	88	3.03	5850	K 0 4 3 2 8 . 0 _ M _ _ _ _ 1 . 1 C - -	36.5	90L
82	11.3	124	2.49	6000	1 1 .		
74	12.45	136	2.35	6000	1 2 .		
65	14.14	155	2.15	6000	1 4 .		
52	17.95	197	1.83	6000	1 8 .		
45	20.4	223	1.68	6000	2 0 .		
37	25.03	273	1.46	6000	2 5 .		
33	27.76	305	1.35	6000	2 8 .		
29	31.54	344	1.25	6000	3 2 .		
26	35.83	390	1.13	6000	3 6 .		
23	39.46	430	1.02	6000	4 0 .		
20	45.39	498	0.88	6000	4 5 .		
19	49.35	539	0.82	6000	5 0 .		
33	28.37	310	2.03	7331	K 0 5 3 2 2 8 . _ M _ _ _ _ 1 . 1 C - -	46.5	90L
28	32.99	361	1.82	7271	3 2 .		
25	36.91	404	1.63	7213	3 6 .		
24	39.34	432	1.52	7172	4 0 .		
20	46.63	511	1.29	7041	4 5 .		
19	49.78	545	1.21	6978	5 0 .		
15	61.78	677	0.97	6680	6 3 .		
13	72.85	796	0.83	5979	7 1 .		
33	27.84	305	2.71	8000	K 0 6 3 2 2 8 . _ M _ _ _ _ 1 . 1 C - -	54.5	90L
29	32.38	354	2.33	8000	3 2 .		
26	36.22	396	2.08	8000	3 6 .		
24	38.61	423	1.95	8000	4 0 .		
20	45.76	502	1.65	8000	4 5 .		
19	48.86	536	1.54	8000	5 0 .		
15	60.62	664	1.24	8000	6 3 .		
13	71.49	780	1.06	7708	7 1 .		
12	78.28	858	0.96	8000	8 0 .		
19	48.01	523	3.06	15000	K 0 7 3 2 4 5 . _ M _ _ _ _ 1 . 1 C - -	73.5	90L
17	54.28	593	2.7	15000	5 0 .		
15	62.94	686	2.33	15000	6 3 .		
12	75.07	815	1.96	14293	7 1 .		
11	82.21	895	1.79	14128	8 0 .		
9.4	98.65	1068	1.5	13590	1 0 0		
8.2	113.5	1234	1.3	13733	1 1 2		
7.3	126.11	1358	1.02	14710	1 2 5		

NOTE

Other output speeds are available using 2 and 8 pole motors - Consult Application Engineering

SERIES K

SELECTION TABLES

GEARED MOTORS

1.1 kW

6 POLE

N2 R/MIN	i	M2 Nm	Fm	N	Unit Designation	Kg	Motor Size
Output Speed	Ratio	Output Torque	Service Factor	Overhung Load	Column Entry 1 Through 20 Spaces to be filled when entering order	Weight of base mount unit	
7.7	120.29	1293	1.29	15000	K 0 7 5 2 1 2 5 _ M _ _ _ _ 1 . 1 C - -	85.5	90L
6.9	133.48	1439	1.16	15000	1 4 0		
6.3	147.09	1586	1.05	15000	1 6 0		
13	72.86	792	3.38	21500	K 0 8 3 2 7 1 . _ M _ _ _ _ 1 . 1 C - -	128.5	90L
12	80.03	871	3.07	21500	8 0 .		
9.4	98.08	1066	2.51	21500	1 0 0		
8.6	107.1	1163	2.3	20165	1 1 2		
7.5	123.33	1336	2.01	19856	1 2 5		
7.7	120.31	1303	2.9	34000	K 0 9 3 1 1 2 5 _ M _ _ _ _ 1 . 1 C - -	181.5	90L
7.2	128.92	1397	3.01	34000	1 4 0		
6.4	144.96	1565	2.69	34000	1 6 0		
1.8	514.73	5520	1.3	43100	K 1 0 5 1 5 0 0 _ M _ _ _ _ 1 . 1 C - -	336.5	90L
1.6	566.2	6070	1.18	43100	5 6 0		
1.4	650.62	6972	1.03	43100	6 3 0		
1.3	722.98	7735	0.93	43100	7 0 0		
1.2	783.15	8372	0.86	43100	8 0 0		
1.7	531.11	5699	2.12	61368	K 1 2 5 1 5 0 0 _ M _ _ _ _ 1 . 1 C - -	496.5	90L
1.6	584.22	6267	1.93	61368	5 6 0		
1.4	671.32	7197	1.68	61368	6 3 0		
1.2	756.72	8109	1.49	61368	7 0 0		
1.1	808.78	8660	1.43	61293	8 0 0		
0.98	946.46	10132	1.19	61368	9 0 0		
0.91	1011.58	10820	1.15	61293	1 0 C		
0.81	1140.25	12190	1.02	61293	1 1 C		
0.75	1225.51	13098	0.92	61368	1 2 C		

1.5 kW

4 POLE

171	8.33	80	1.7	3590	K 0 3 3 2 8 . 0 _ M _ _ _ _ 1 . 5 A - -	31.5	90L
126	11.25	109	1.42	3774	1 1 .		
111	12.8	124	1.31	3841	1 2 .		
98	14.5	141	1.21	3895	1 4 .		
77	18.54	180	1.02	3970	1 8 .		
71	19.98	195	0.97	3980	2 0 .		
176	8.05	78	3.15	5080	K 0 4 3 2 8 . 0 _ M _ _ _ _ 1 . 5 A - -	36.5	90L
126	11.3	109	2.59	5514	1 1 .		
114	12.45	121	2.44	5639	1 2 .		
100	14.14	137	2.25	5745	1 4 .		
79	17.95	174	1.91	5715	1 8 .		
70	20.4	198	1.75	5746	2 0 .		
57	25.03	243	1.52	5740	2 5 .		
51	27.76	270	1.41	5735	2 8 .		
45	31.54	306	1.29	5712	3 2 .		
40	35.83	348	1.2	6000	3 6 .		
36	39.46	383	1.09	6000	4 0 .		
31	45.39	442	0.99	6000	4 5 .		
29	49.35	479	0.92	6000	5 0 .		
50	28.37	276	2.12	6512	K 0 5 3 2 2 8 . _ M _ _ _ _ 1 . 5 A - -	46.5	90L
43	32.99	320	1.89	6613	3 2 .		
38	36.91	359	1.78	6650	3 6 .		
36	39.34	383	1.65	6596	4 0 .		
30	46.63	453	1.45	6490	4 5 .		
29	49.78	484	1.36	6427	5 0 .		
23	61.78	600	1.1	6600	6 3 .		
19	72.85	705	0.93	6420	7 1 .		
18	79.77	770	0.86	6280	8 0 .		
51	27.84	270	3.05	7546	K 0 6 3 2 2 8 . _ M _ _ _ _ 1 . 5 A - -	54.5	90L
44	32.38	314	2.62	7709	3 2 .		
39	36.22	352	2.34	7667	3 6 .		
37	38.61	375	2.2	7637	4 0 .		
31	45.76	444	1.86	7973	4 5 .		
29	48.86	474	1.74	7943	5 0 .		
23	60.62	589	1.4	8000	6 3 .		
20	71.49	692	1.19	8000	7 1 .		
18	78.28	758	1.09	8000	8 0 .		
15	95.93	931	0.89	8000	1 0 0		
13	106.93	1029	0.8	8000	1 1 2		
30	48.01	465	3.44	15000	K 0 7 3 2 4 5 . _ M _ _ _ _ 1 . 5 A - -	73.5	90L
26	54.28	525	3.04	15000	5 0 .		
23	62.94	608	2.63	14503	6 3 .		
19	75.07	725	2.21	14434	7 1 .		
17	82.21	793	2.02	14393	8 0 .		
14	98.65	949	1.68	14400	1 0 0		
13	113.5	1094	1.46	15000	1 1 2		
11	126.11	1207	1.14	15000	1 2 5		

NOTE

Other output speeds are available using 2 and 8 pole motors - Consult Application Engineering

SERIES K SELECTION TABLES GEARED MOTORS

1.5 kW

4 POLE

N2 R/MIN	i	M2 Nm	Fm	N	Unit Designation	Kg	
Output Speed	Ratio	Output Torque	Service Factor	Overhung Load	Column Entry [1] Through [20] Spaces to be filled when entering order	Weight of base mount unit	Motor Size
12	120.29	1145	1.46	15000	K 0 7 5 2 1 2 5 _ M _ _ _ _ 1 . 5 A - -	85.5	90L
11	133.48	1275	1.31	15000	1 4 0		
10	147.09	1405	1.19	15000	1 6 0		
6.7	211.12	2011	0.83	15000	2 0 0		
19	72.86	704	3.81	21500	K 0 8 3 2 7 1 . _ M _ _ _ _ 1 . 5 A - -	128.5	90L
18	80.03	773	3.47	21500	8 0 .		
14	98.08	948	2.83	20713	1 0 0		
13	107.1	1033	2.59	20672	1 1 2		
12	123.33	1186	2.26	20437	1 2 5		
13	106.99	1033	3.66	34000	K 0 9 3 1 1 1 2 _ M _ _ _ _ 1 . 5 A - -	181.5	90L
12	120.31	1157	3.26	34000	1 2 5		
11	128.92	1240	3.39	34000	1 4 0		
10	144.96	1389	3.03	34000	1 6 0		
2.8	514.73	4889	1.47	43100	K 1 0 5 1 5 0 0 0 _ M _ _ _ _ 1 . 5 A - -	336.5	90L
2.5	566.2	5378	1.34	43100	5 6 0		
2.2	650.62	6179	1.16	43100	6 3 0		
2	722.98	6853	1.05	43100	7 0 0		
1.8	783.15	7416	0.97	43100	8 0 0		
1.6	904.27	8568	0.84	43100	9 0 0		
2.7	531.11	5054	2.39	61368	K 1 2 5 1 5 0 0 0 _ M _ _ _ _ 1 . 5 A - -	496.5	90L
2.4	584.22	5559	2.18	61368	5 6 0		
2.1	671.32	6385	1.89	61368	6 3 0		
1.9	756.72	7191	1.68	61368	7 0 0		
1.8	808.78	7681	1.62	61293	8 0 0		
1.5	946.46	8989	1.35	61368	9 0 0		
1.4	1011.58	9600	1.29	61293	1 0 C		
1.2	1140.25	10812	1.15	61293	1 1 C		
1.2	1225.51	11625	1.04	61368	1 2 C		
0.94	1518.59	14380	0.86	61293	1 4 C		

1.5 kW

6 POLE

112	8.33	124	1.21	4320	K 0 3 3 2 8 . 0 _ M _ _ _ _ 1 . 5 C - -	42	100L
83	11.25	168	1.01	4500	1 1 .		
73	12.80	191	0.93	4520	1 2 .		
64	14.50	217	0.85	4530	1 4 .		
115	8.05	120	2.32	5480	K 0 4 3 2 8 . 0 _ M _ _ _ _ 1 . 5 C - -	49	100L
82	11.30	169	1.90	5660	1 1 .		
75	12.45	186	1.78	6000	1 2 .		
66	14.14	211	1.64	6000	1 4 .		
52	17.95	268	1.39	6000	1 8 .		
46	20.40	305	1.27	6000	2 0 .		
37	25.03	374	1.10	6000	2 5 .		
33	27.76	415	1.02	6000	2 8 .		
29	31.54	471	0.92	6000	3 2 .		
26	35.83	535	0.82	6000	3 6 .		
72	12.78	191	2.63	6140	K 0 5 3 2 1 2 . _ M _ _ _ _ 1 . 5 C - -	59	100L
64	14.35	214	2.43	6270	1 4 .		
51	18.22	272	2.06	6480	1 8 .		
45	20.66	309	1.88	6570	2 0 .		
38	24.64	368	1.65	6670	2 5 .		
33	28.37	424	1.49	6567	2 8 .		
28	32.99	492	1.34	6437	3 2 .		
25	36.91	551	1.19	6313	3 6 .		
24	39.34	589	1.12	6225	4 0 .		
20	46.63	697	0.94	5946	4 5 .		
19	49.78	743	0.89	5812	5 0 .		
52	17.88	267	3.02	8000	K 0 6 3 2 1 8 . _ M _ _ _ _ 1 . 5 C - -	67	100L
46	20.27	303	2.72	8000	2 0 .		
38	24.18	362	2.28	8000	2 5 .		
33	27.84	416	1.98	8000	2 8 .		
29	32.38	483	1.71	8000	3 2 .		
26	36.22	540	1.53	8000	3 6 .		
24	38.61	577	1.43	8000	4 0 .		
20	45.76	684	1.21	8000	4 5 .		
19	48.86	731	1.13	8000	5 0 .		
15	60.62	906	0.91	8000	6 3 .		
28	33.52	500	3.2	15000	K 0 7 3 2 3 2 . _ M _ _ _ _ 1 . 5 C - -	85	100L
24	38.01	566	2.83	15000	3 6 .		
22	41.92	624	2.56	15000	4 0 .		
19	48.01	713	2.24	14282	4 5 .		
17	54.28	808	1.98	14194	5 0 .		
15	62.94	936	1.71	14286	6 3 .		
12	75.07	1111	1.44	13486	7 1 .		
11	82.21	1220	1.31	13133	8 0 .		
9.4	98.65	1456	1.1	12564	1 0 0		
8.2	113.5	1682	0.95	12812	1 1 2		

NOTE

Other output speeds are available using 2 and 8 pole motors - Consult Application Engineering

SERIES K

SELECTION TABLES

GEARED MOTORS

1.5 kW

6 POLE

N2 R/MIN	i	M2 Nm	Fm	N	Unit Designation	Kg	Motor Size
Output Speed	Ratio	Output Torque	Service Factor	Overhung Load	Column Entry 1 Through 20 Spaces to be filled when entering order	Weight of base mount unit	
18	51.54	766	3.49	21500	K 0 8 3 2 5 0 . _ M _ _ _ _ _ 1 . 5 C - -	140	100L
15	62.47	929	2.88	21500	6 3 .		
13	72.86	1080	2.48	20481	7 1 .		
12	80.03	1188	2.25	20323	8 0 .		
9.4	98.08	1453	1.84	20010	1 0 0		
8.6	107.1	1586	1.69	18640	1 1 2		
7.5	123.33	1821	1.47	17978	1 2 5		
7	132.19	1930	1.4	15674	K 0 8 5 2 1 2 5 _ M _ _ _ _ _ 1 . 5 C - -	166	100L
6.4	144.67	2111	1.28	15674	1 4 0		
5.7	163.67	2383	1.14	15674	1 6 0		
4.5	203.4	2968	0.91	15674	2 0 0		
11	84.89	1257	3.35	34000	K 0 9 3 1 9 0 . _ M _ _ _ _ _ 1 . 5 C - -	193	100L
10	93.71	1388	3.03	34000	1 0 0		
8.6	106.99	1586	2.38	34000	1 1 2		
7.7	120.31	1777	2.13	34000	1 2 5		
7.2	128.92	1905	2.21	34000	1 4 0		
6.4	144.96	2134	1.97	34000	1 6 0		
5.7	160.93	2355	1.6	34000	K 0 9 5 1 1 6 0 _ M _ _ _ _ _ 1 . 5 C - -	224	100L
4.1	226.25	3311	1.14	34000	2 0 0		
3.6	253.59	3711	1.02	34000	2 5 0		
3.3	281.74	4116	0.92	34000	2 8 0		
2.9	316.25	4619	0.82	34000	3 2 0		
6.4	144.88	2144	3.35	43400	K 1 0 3 1 1 6 0 _ M _ _ _ _ _ 1 . 5 C - -	317	100L
1.8	514.73	7527	0.95	43100	K 1 0 5 1 5 0 0 _ M _ _ _ _ _ 1 . 5 C - -	349	100L
1.6	566.2	8278	0.87	43100	5 6 0		
1.7	531.11	7772	1.56	61368	K 1 2 5 1 5 0 0 _ M _ _ _ _ _ 1 . 5 C - -	509	100L
1.6	584.22	8546	1.42	61368	5 6 0		
1.4	671.32	9815	1.23	61368	6 3 0		
1.2	756.72	11058	1.09	61368	7 0 0		
1.1	808.78	11810	1.05	61293	8 0 0		
0.98	946.46	13817	0.88	61368	9 0 0		
0.91	1011.58	14755	0.84	61293	1 0 C		

2.2 kW

4 POLE

171	8.33	118	1.16	3230	K 0 3 3 2 8 . 0 _ M _ _ _ _ _ 2 . 2 K - -	37	100L
126	11.25	160	0.97	3290	1 1 .		
111	12.8	183	0.89	3290	1 2 .		
98	14.5	207	0.82	3270	1 4 .		
176	8.05	114	2.15	4800	K 0 4 3 2 8 . 0 _ M _ _ _ _ _ 2 . 2 K - -	42	100L
126	11.3	161	1.76	5120	1 1 .		
114	12.45	177	1.66	5200	1 2 .		
100	14.14	201	1.53	5300	1 4 .		
79	17.95	256	1.3	5450	1 8 .		
70	20.4	291	1.19	5510	2 0 .		
57	25.03	356	1.04	5550	2 5 .		
51	27.76	396	0.96	5540	2 8 .		
45	31.54	449	0.88	5500	3 2 .		
176	8.11	115	3.42	4800	K 0 5 3 2 8 . 0 _ M _ _ _ _ _ 2 . 2 A - -	59	100L
125	11.4	162	2.77	5126	1 1 .		
111	12.78	181	2.56	5223	1 2 .		
99	14.35	204	2.38	5310	1 4 .		
78	18.22	259	2	5460	1 8 .		
69	20.66	293	1.83	5512	2 0 .		
58	24.64	350	1.61	5541	2 5 .		
50	28.37	403	1.45	5535	2 8 .		
43	32.99	468	1.3	5477	3 2 .		
39	36.91	525	1.22	5390	3 6 .		
36	39.34	560	1.13	5286	4 0 .		
31	46.63	663	0.99	5081	4 5 .		
29	49.78	708	0.93	4959	5 0 .		
114	12.54	178	3.74	7760	K 0 6 3 2 1 2 . _ M _ _ _ _ _ 2 . 2 A - -	67	100L
101	14.08	200	3.47	7970	1 4 .		
80	17.88	254	2.94	8000	1 8 .		
70	20.27	288	2.69	8000	2 0 .		
59	24.18	344	2.37	8000	2 5 .		
51	27.84	395	2.09	7123	2 8 .		
44	32.38	459	1.8	7437	3 2 .		
39	36.22	515	1.6	7357	3 6 .		
37	38.61	549	1.51	7299	4 0 .		
31	45.76	649	1.27	7948	4 5 .		
29	48.86	693	1.19	7890	5 0 .		
24	60.62	861	0.96	8000	6 3 .		
20	71.49	1011	0.82	8000	7 1 .		

NOTE

Other output speeds are available using 2 and 8 pole motors - Consult Application Engineering

SERIES K

SELECTION TABLES

GEARED MOTORS

2.2 kW

4 POLE

N2 R/MIN	i	M2 Nm	Fm	N	Unit Designation	Kg	Motor Size
Output Speed	Ratio	Output Torque	Service Factor	Overhung Load	Column Entry 1 Through 20 Spaces to be filled when entering order	Weight of base mount unit	
113	12.54	179	3.73	7760	K 0 6 3 2 1 2 . _ M _ _ _ _ 2 . 2 K - -	60	90LA
101	14.08	201	3.46	7970	1 4 .		
79	17.88	255	2.93	8000	1 8 .		
70	20.27	289	2.68	8000	2 0 .		
59	24.18	345	2.36	8000	2 5 .		
51	27.84	397	2.08	7123	2 8 .		
44	32.38	461	1.79	7437	3 2 .		
39	36.22	517	1.6	7357	3 6 .		
37	38.61	551	1.5	7299	4 0 .		
31	45.76	651	1.27	7948	4 5 .		
29	48.86	695	1.19	7890	5 0 .		
23	60.62	864	0.96	8000	6 3 .		
20	71.49	1015	0.81	8000	7 1 .		
54	26.52	376	3.95	13300	K 0 7 3 2 2 5 . _ M _ _ _ _ 2 . 2 A - -	85	100L
49	29.17	414	3.69	13500	2 8 .		
43	33.52	475	3.32	13900	3 2 .		
37	38.01	538	2.97	14300	3 6 .		
34	41.92	593	2.69	14600	4 0 .		
30	48.01	679	2.35	13982	4 5 .		
26	54.28	768	2.08	13900	5 0 .		
23	62.94	888	1.8	13634	6 3 .		
19	75.07	1059	1.51	13444	7 1 .		
17	82.21	1159	1.38	13331	8 0 .		
14	98.65	1388	1.15	13840	1 0 0		
13	113.5	1598	1	15000	1 1 2		
54	26.52	378	3.94	13300	K 0 7 3 2 2 5 . _ M _ _ _ _ 2 . 2 K - -	79	90LA
49	29.17	416	3.68	13500	2 8 .		
42	33.52	477	3.31	13900	3 2 .		
37	38.01	540	2.96	14300	3 6 .		
34	41.92	596	2.68	14600	4 0 .		
30	48.01	682	2.35	13982	4 5 .		
26	54.28	771	2.07	13900	5 0 .		
23	62.94	891	1.79	13634	6 3 .		
19	75.07	1063	1.5	13444	7 1 .		
17	82.21	1163	1.38	13331	8 0 .		
14	98.65	1393	1.15	13840	1 0 0		
13	113.5	1604	1	15000	1 1 2		
12	120.29	1680	0.99	15000	K 0 7 5 2 1 2 5 _ M _ _ _ _ 2 . 2 K - -	91	100L
11	133.48	1871	0.89	15000	1 4 0		
10	147.09	2062	0.81	15000	1 6 0		
28	51.54	729	3.67	18855	K 0 8 3 2 5 0 . _ M _ _ _ _ 2 . 2 A - -	140	100L
23	62.47	883	3.03	19587	6 3 .		
20	72.86	1029	2.6	19997	7 1 .		
18	80.03	1129	2.37	19929	8 0 .		
15	98.08	1385	1.93	19337	1 0 0		
13	107.1	1511	1.77	19224	1 1 2		
12	123.33	1733	1.55	18579	1 2 5		
11	132.19	1830	1.48	15674	K 0 8 5 2 1 2 5 _ M _ _ _ _ 2 . 2 A - -	166	100L
10	144.67	2000	1.36	15674	1 4 0		
8.7	163.67	2256	1.2	15674	1 6 0		
7	203.4	2812	0.96	15674	2 0 0		
18	77.78	1100	3.44	34000	K 0 9 3 1 8 0 . _ M _ _ _ _ 2 . 2 A - -	193	100L
17	84.89	1196	3.52	34000	9 0 .		
15	93.71	1319	3.19	34000	1 0 0		
13	106.99	1511	2.5	34000	1 1 2		
12	120.31	1692	2.23	34000	1 2 5		
11	128.92	1812	2.32	34000	1 4 0		
10	144.96	2031	2.07	34000	1 6 0		
8.9	160.93	2234	1.69	34000	K 0 9 5 1 1 6 0 _ M _ _ _ _ 2 . 2 A - -	224	100L
6.3	226.25	3141	1.2	34000	2 0 0		
5.6	253.59	3520	1.07	34000	2 5 0		
5.1	281.74	3902	0.97	34000	2 8 0		
4.5	316.25	4380	0.86	34000	3 2 0		
11	134.85	1900	3.78	43405	K 1 0 3 1 1 4 0 _ M _ _ _ _ 2 . 2 A - -	317	100L
10	144.88	2039	3.52	43405	1 6 0		
2.8	514.73	7146	1.01	43100	K 1 0 5 1 5 0 0 _ M _ _ _ _ 2 . 2 A - -	349	100L
2.5	566.2	7860	0.91	43100	5 6 0		
2.7	531.11	7387	1.64	61368	K 1 2 5 1 5 0 0 _ M _ _ _ _ 2 . 2 A - -	509	100L
2.4	584.22	8124	1.49	61368	5 6 0		
2.1	671.32	9332	1.3	61368	6 3 0		
1.9	756.72	10510	1.15	61368	7 0 0		
1.8	808.78	11226	1.11	61293	8 0 0		
1.5	946.46	13137	0.92	61368	9 0 0		
1.4	1011.58	14031	0.89	61293	1 0 C		

NOTE

Other output speeds are available using 2 and 8 pole motors - Consult Application Engineering

SERIES K

SELECTION TABLES

GEARED MOTORS

2.2 kW

6 POLE

N2 R/MIN	i	M2 Nm	Fm	N	Unit Designation	Kg	Motor Size
Output Speed	Ratio	Output Torque	Service Factor	Overhung Load	Column Entry 1 Through 20 Spaces to be filled when entering order	Weight of base mount unit	
117	8.05	175	1.60	5050	K 0 4 3 2 8 . 0 _ M _ _ _ _ _ 2 . 2 C - -	54	112M
83	11.30	245	1.31	5160	1 1 .		
76	12.45	270	1.23	5200	1 2 .		
67	14.14	306	1.13	5300	1 4 .		
52	17.95	389	0.96	5300	1 8 .		
46	20.40	442	0.88	5300	2 0 .		
117	8.11	173	2.47	5180	K 0 5 3 2 8 . 0 _ M _ _ _ _ _ 2 . 2 C - -	66	112M
83	11.4	243	1.99	5420	1 1 .		
74	12.78	273	1.84	5480	1 2 .		
66	14.35	307	1.7	5520	1 4 .		
52	18.22	389	1.44	5530	1 8 .		
46	20.66	442	1.31	5500	2 0 .		
39	24.64	526	1.16	5380	2 5 .		
33	28.37	605	1.04	5230	2 8 .		
29	32.99	703	0.94	4980	3 2 .		
26	36.91	787	0.84	4740	3 6 .		
119	7.96	170	3.58	7680	K 0 6 3 2 8 . 0 _ M _ _ _ _ _ 2 . 2 C - -	74	112M
85	11.19	239	2.89	8000	1 1 .		
76	12.54	268	2.69	8000	1 2 .		
67	14.08	300	2.49	8000	1 4 .		
53	17.88	382	2.11	8000	1 8 .		
47	20.27	433	1.91	8000	2 0 .		
39	24.18	517	1.6	8000	2 5 .		
34	27.84	595	1.39	8000	2 8 .		
29	32.38	691	1.2	8000	3 2 .		
26	36.22	772	1.07	8000	3 6 .		
25	38.61	824	1	8000	4 0 .		
21	45.76	977	0.85	8000	4 5 .		
36	26.52	564	2.83	14400	K 0 7 3 2 2 5 . _ M _ _ _ _ _ 2 . 2 C - -	92	112M
33	29.17	621	2.57	14700	2 8 .		
28	33.52	714	2.24	13951	3 2 .		
25	38.01	808	1.98	13860	3 6 .		
23	41.92	891	1.79	13769	4 0 .		
20	48.01	1019	1.57	13027	4 5 .		
18	54.28	1154	1.39	12785	5 0 .		
15	62.94	1337	1.2	13038	6 3 .		
13	75.07	1587	1.01	12073	7 1 .		
12	82.21	1743	0.92	11390	8 0 .		
26	36.88	783	3.42	19200	K 0 8 3 2 3 6 . _ M _ _ _ _ _ 2 . 2 C - -	147	112M
24	40.36	858	3.12	19500	4 0 .		
21	45.66	970	2.76	20000	4 5 .		
18	51.54	1095	2.45	19918	5 0 .		
15	62.47	1326	2.02	19682	6 3 .		
13	72.86	1543	1.74	18700	7 1 .		
12	80.03	1697	1.58	18265	8 0 .		
10	98.08	2075	1.29	17403	1 0 0		
8.9	107.1	2265	1.18	15972	1 1 2		
7.7	123.33	2601	1.03	14691	1 2 5		
7.2	132.19	2757	0.98	15674	K 0 8 5 2 1 2 5 _ M _ _ _ _ _ 2 . 2 C - -	173	112M
6.6	144.67	3015	0.9	15674	1 4 0		
16	60.1	1273	3.31	34000	K 0 9 3 1 6 3 . _ M _ _ _ _ _ 2 . 2 C - -	200	112M
13	70.45	1495	2.53	34000	7 1 .		
12	77.78	1650	2.29	34000	8 0 .		
11	84.89	1796	2.34	34000	9 0 .		
10	93.71	1982	2.12	34000	1 0 0		
8.9	106.99	2265	1.67	34000	1 1 2		
7.9	120.31	2538	1.49	34000	1 2 5		
7.4	128.92	2720	1.55	34000	1 4 0		
6.6	144.96	3048	1.38	34000	1 6 0		
5.9	160.93	3364	1.12	34000	K 0 9 5 1 1 6 0 _ M _ _ _ _ _ 2 . 2 C - -	231	112M
8.5	112.03	2375	3.03	43400	K 1 0 3 1 1 1 2 _ M _ _ _ _ _ 2 . 2 C - -	324	112M
7.9	120.36	2549	2.82	43400	1 2 5		
7	134.85	2854	2.52	43400	1 4 0		
6.6	144.88	3062	2.35	43330	1 6 0		
6.5	145.85	3082	3.99	61700	K 1 2 3 1 1 6 0 _ M _ _ _ _ _ 2 . 2 C - -	458	112M
1.8	531.11	11099	1.09	61368	K 1 2 5 1 5 0 0 _ M _ _ _ _ _ 2 . 2 C - -	516	112M
1.6	584.22	12205	0.99	61368	5 6 0		
1.4	671.32	14017	0.86	61368	6 3 0		

NOTE

Other output speeds are available using 2 and 8 pole motors - Consult Application Engineering

SERIES K

SELECTION TABLES

GEARED MOTORS

3.0 kW

4 POLE

N2 R/MIN	i	M2 Nm	Fm	N	Unit Designation	Kg	Motor Size
Output Speed	Ratio	Output Torque	Service Factor	Overhung Load	Column Entry 1 Through 20 Spaces to be filled when entering order	Weight of base mount unit	
178	8.05	157	1.64	4450	K 0 4 3 2 8 . 0 _ M _ _ _ _ 3 . 0 A - -	54	100L
127	11.30	220	1.34	4500	1 1 .		
115	12.45	242	1.26	4670	1 2 .		
101	14.14	275	1.16	4680	1 4 .		
80	17.95	349	0.99	4690	1 8 .		
70	20.40	396	0.90	4690	2 0 .		
176	8.11	157	2.51	4480	K 0 5 3 2 8 . 0 _ M _ _ _ _ 3 . 0 A - -	59	100L
125	11.4	220	2.03	4676	1 1 .		
111	12.78	247	1.88	4718	1 2 .		
99	14.35	278	1.74	4743	1 4 .		
78	18.22	353	1.47	4740	1 8 .		
69	20.66	400	1.34	4693	2 0 .		
58	24.64	477	1.18	4571	2 5 .		
50	28.37	550	1.06	4420	2 8 .		
43	32.99	638	0.95	4180	3 2 .		
39	36.91	716	0.89	3950	3 6 .		
36	39.34	764	0.83	3790	4 0 .		
179	7.96	153	3.64	8000	K 0 6 3 2 8 . 0 _ M _ _ _ _ 3 . 0 A - -	67	100L
127	11.19	217	2.95	8000	1 1 .		
114	12.54	243	2.75	7333	1 2 .		
101	14.08	273	2.55	7490	1 4 .		
80	17.88	347	2.16	7483	1 8 .		
70	20.27	394	1.97	7452	2 0 .		
59	24.18	469	1.74	7384	2 5 .		
51	27.84	539	1.53	6640	2 8 .		
44	32.38	627	1.32	7127	3 2 .		
39	36.22	703	1.18	7003	3 6 .		
37	38.61	749	1.1	6913	4 0 .		
31	45.76	885	0.93	7920	4 5 .		
29	48.86	945	0.87	7830	5 0 .		
54	26.52	513	2.9	12530	K 0 7 3 2 2 5 . _ M _ _ _ _ 3 . 0 A - -	85	100L
49	29.17	565	2.71	12663	2 8 .		
43	33.52	648	2.44	12938	3 2 .		
37	38.01	734	2.18	13207	3 6 .		
34	41.92	809	1.98	13387	4 0 .		
30	48.01	926	1.73	12819	4 5 .		
26	54.28	1048	1.53	12643	5 0 .		
23	62.94	1211	1.32	12641	6 3 .		
19	75.07	1445	1.11	12313	7 1 .		
17	82.21	1580	1.01	12117	8 0 .		
14	98.65	1893	0.85	13200	1 0 0		
39	36.88	711	3.77	15200	K 0 8 3 2 3 6 . _ M _ _ _ _ 3 . 0 A - -	140	100L
35	40.36	779	3.44	15200	4 0 .		
31	45.66	881	3.04	15200	4 5 .		
28	51.54	995	2.69	17609	5 0 .		
23	62.47	1204	2.22	18084	6 3 .		
20	72.86	1403	1.91	18280	7 1 .		
18	80.03	1540	1.74	18134	8 0 .		
15	98.08	1889	1.42	17765	1 0 0		
13	107.1	2060	1.3	17568	1 1 2		
12	123.33	2364	1.13	16455	1 2 5		
11	132.19	2495	1.09	15674	K 0 8 5 2 1 2 5 _ M _ _ _ _ 3 . 0 A - -	166	100L
10	144.67	2727	0.99	15674	1 4 0		
8.7	163.67	3076	0.88	15674	1 6 0		
24	60.1	1157	3.64	34000	K 0 9 3 1 6 3 . _ M _ _ _ _ 3 . 0 A - -	193	100L
20	70.45	1359	2.78	34000	7 1 .		
18	77.78	1500	2.52	34000	8 0 .		
17	84.89	1630	2.58	34000	9 0 .		
15	93.71	1799	2.34	34000	1 0 0		
13	106.99	2060	1.83	34000	1 1 2		
12	120.31	2307	1.64	34000	1 2 5		
11	128.92	2471	1.7	34000	1 4 0		
10	144.96	2769	1.52	34000	1 6 0		
8.9	160.93	3046	1.24	34000	K 0 9 5 1 1 6 0 _ M _ _ _ _ 3 . 0 A - -	224	100L
6.3	226.25	4283	0.88	34000	2 0 0		
14	99.7	1925	3.73	43400	K 1 0 3 1 1 0 0 _ M _ _ _ _ 3 . 0 A - -	317	100L
13	112.03	2151	3.34	43400	1 1 2		
12	120.36	2315	3.11	43400	1 2 5		
11	134.85	2591	2.77	43359	1 4 0		
10	144.88	2781	2.58	43359	1 6 0		
2.7	531.11	10073	1.2	61368	K 1 2 5 1 5 0 0 _ M _ _ _ _ 3 . 0 A - -	509	100L
2.4	584.22	11079	1.09	61368	5 6 0		
2.1	671.32	12725	0.95	61368	6 3 0		
1.9	756.72	14333	0.84	61368	7 0 0		
1.8	808.78	15308	0.81	61293	8 0 0		

NOTE

Other output speeds are available using 2 and 8 pole motors - Consult Application Engineering

SERIES K

SELECTION TABLES

GEARED MOTORS

3.0 kW

6 POLE

N2 R/MIN	i	M2 Nm	Fm	N	Unit Designation	Kg	Motor Size
Output Speed	Ratio	Output Torque	Service Factor	Overhung Load	Column Entry 1 Through 20 Spaces to be filled when entering order	Weight of base mount unit	
111	8.6	247	2.87	10700	K 0 7 3 2 8 . 0 _ M _ _ _ _ 3 . 0 C - -	111	132S
80	11.91	344	2.87	11500	1 1 .		
71	13.37	386	2.87	11800	1 2 .		
65	14.71	425	2.87	12100	1 4 .		
50	19.21	555	2.63	12700	1 8 .		
44	21.84	632	2.4	12900	2 0 .		
36	26.52	765	2.09	13253	2 5 .		
33	29.17	843	1.9	13424	2 8 .		
28	33.52	968	1.65	12753	3 2 .		
25	38.01	1096	1.46	12558	3 6 .		
23	41.92	1209	1.32	12363	4 0 .		
20	48.01	1382	1.16	11592	4 5 .		
18	54.28	1566	1.02	11174	5 0 .		
15	62.94	1813	0.88	11612	6 3 .		
38	25.35	734	3.65	16700	K 0 8 3 2 2 5 . _ M _ _ _ _ 3 . 0 C - -	167	132S
33	28.56	825	3.25	17100	2 8 .		
29	33.24	959	2.79	17500	3 2 .		
26	36.88	1063	2.52	19200	3 6 .		
24	40.36	1164	2.3	19500	4 0 .		
21	45.66	1316	2.04	20000	4 5 .		
19	51.54	1485	1.8	18110	5 0 .		
15	62.47	1800	1.49	17605	6 3 .		
13	72.86	2093	1.28	16663	7 1 .		
12	80.03	2302	1.16	15912	8 0 .		
10	98.08	2816	0.95	14424	1 0 0		
8.9	107.1	3073	0.87	12922	1 1 2		
21	44.89	1295	2.92	34000	K 0 9 3 1 4 5 . _ M _ _ _ _ 3 . 0 C - -	220	132S
19	49.87	1439	2.63	34000	5 0 .		
18	54.09	1555	2.71	34000	5 6 .		
16	60.1	1727	2.44	34000	6 3 .		
14	70.45	2028	1.86	34000	7 1 .		
12	77.78	2239	1.69	34000	8 0 .		
11	84.89	2436	1.73	34000	9 0 .		
10	93.71	2689	1.57	34000	1 0 0		
8.9	106.99	3072	1.23	34000	1 1 2		
7.9	120.31	3443	1.1	34000	1 2 5		
7.4	128.92	3690	1.14	34000	1 4 0		
6.6	144.96	4135	1.02	34000	1 6 0		
12	82.83	2387	3.01	43400	K 1 0 3 1 8 0 . _ M _ _ _ _ 3 . 0 C - -	344	132S
11	86.53	2492	2.88	43400	9 0 .		
10	99.7	2868	2.51	43400	1 0 0		
8.5	112.03	3221	2.23	43400	1 1 2		
7.9	120.36	3458	2.08	43400	1 2 5		
7.1	134.85	3871	1.86	43324	1 4 0		
6.6	144.88	4153	1.73	43250	1 6 0		
5.7	166.84	4731	1.52	43100	K 1 0 5 1 1 6 0 _ M _ _ _ _ 3 . 0 C - -	375	132S
4.1	231.1	6553	1.1	43100	2 0 0		
3.7	259.6	7360	0.98	43100	2 5 0		
3.3	285.44	8093	0.89	43100	2 8 0		
3	317.19	8977	0.8	43100	3 2 0		
7.9	121.06	3475	3.48	61700	K 1 2 3 1 1 2 5 _ M _ _ _ _ 3 . 0 C - -	478	132S
7	137.09	3929	3.13	61700	1 4 0		
6.5	145.85	4181	2.94	61700	1 6 0		
5.5	172.15	4886	2.48	61368	K 1 2 5 1 1 6 0 _ M _ _ _ _ 3 . 0 C - -	535	132S
3.6	268.79	7623	1.59	61368	2 0 0		
4	238.46	6768	1.79	61368	2 5 0		
3.2	301.94	8562	1.41	61368	2 8 0		
2.9	331.99	9414	1.28	61368	3 2 0		
2.5	384.7	10913	1.11	61368	3 6 0		
2.2	437.38	12404	0.97	61368	4 0 0		
1.9	493.02	13973	0.87	61368	4 5 0		
1.8	531.11	15056	0.8	61368	5 0 0		

NOTE

Other output speeds are available using 2 and 8 pole motors - Consult Application Engineering

SERIES K

SELECTION TABLES

GEARED MOTORS

4.0 kW

4 POLE

N2 R/MIN	i	M2 Nm	Fm	N	Unit Designation	Kg	Motor Size
Output Speed	Ratio	Output Torque	Service Factor	Overhung Load	Column Entry 1 Through 20 Spaces to be filled when entering order	Weight of base mount unit	
178	8.05	209	1.23	4040	K 0 4 3 2 8 . 0 _ M _ _ _ _ 4 . 0 A - -	54	112M
127	11.30	293	1.00	4080	1 1 .		
115	12.45	323	0.95	4000	1 2 .		
101	14.14	366	0.87	4000	1 4 .		
177	8.11	207	1.9	4080	K 0 5 3 2 8 . 0 _ M _ _ _ _ 4 . 0 A - -	66	112M
126	11.4	292	1.53	4113	1 1 .		
112	12.78	328	1.42	4086	1 2 .		
100	14.35	368	1.32	4034	1 4 .		
79	18.22	468	1.11	3840	1 8 .		
69	20.66	530	1.01	3670	2 0 .		
58	24.64	632	0.89	3360	2 5 .		
180	7.96	203	2.75	8000	K 0 6 3 2 8 . 0 _ M _ _ _ _ 4 . 0 A - -	74	112M
128	11.19	287	2.23	8000	1 1 .		
114	12.54	322	2.07	6800	1 2 .		
102	14.08	362	1.92	6890	1 4 .		
80	17.88	459	1.63	6838	1 8 .		
71	20.27	521	1.49	6767	2 0 .		
59	24.18	621	1.31	6614	2 5 .		
52	27.84	714	1.16	6036	2 8 .		
44	32.38	830	0.99	6740	3 2 .		
40	36.22	931	0.89	6560	3 6 .		
37	38.61	991	0.83	6430	4 0 .		
167	8.6	218	3.24	9380	K 0 7 3 2 8 . 0 _ M _ _ _ _ 4 . 0 A - -	92	112M
121	11.91	303	3.24	10100	1 1 .		
107	13.37	342	3.24	10300	1 2 .		
98	14.71	376	3.24	10500	1 4 .		
75	19.21	491	2.75	11000	1 8 .		
66	21.84	560	2.5	11200	2 0 .		
54	26.52	680	2.19	11569	2 5 .		
49	29.17	748	2.04	11617	2 8 .		
43	33.52	858	1.84	11737	3 2 .		
38	38.01	972	1.65	11841	3 6 .		
34	41.92	1072	1.49	11872	4 0 .		
30	48.01	1227	1.3	11365	4 5 .		
26	54.28	1387	1.15	11073	5 0 .		
23	62.94	1604	1	11400	6 3 .		
19	75.07	1913	0.84	10900	7 1 .		
57	25.35	648	3.76	14500	K 0 8 3 2 2 5 . _ M _ _ _ _ 4 . 0 A - -	147	112M
50	28.56	730	3.46	14900	2 8 .		
43	33.24	850	3.12	15200	3 2 .		
39	36.88	941	2.85	14811	3 6 .		
36	40.36	1031	2.6	14811	4 0 .		
31	45.66	1167	2.3	14811	4 5 .		
28	51.54	1317	2.03	16051	5 0 .		
23	62.47	1595	1.68	16205	6 3 .		
20	72.86	1857	1.44	16134	7 1 .		
18	80.03	2039	1.31	15890	8 0 .		
15	98.08	2501	1.07	15800	1 0 0		
13	107.1	2728	0.98	15500	1 1 2		
12	123.33	3130	0.86	13800	1 2 5		
11	132.19	3304	0.82	15674	K 0 8 5 2 1 2 5 _ M _ _ _ _ 4 . 0 A - -	173	112M
32	44.89	1148	3.29	34000	K 0 9 3 1 4 5 . _ M _ _ _ _ 4 . 0 A - -	200	112M
29	49.87	1273	2.97	34000	5 0 .		
27	54.09	1383	3.04	34000	5 6 .		
24	60.1	1532	2.75	34000	6 3 .		
20	70.45	1799	2.1	34000	7 1 .		
18	77.78	1986	1.9	34000	8 0 .		
17	84.89	2159	1.95	34000	9 0 .		
15	93.71	2383	1.77	34000	1 0 0		
13	106.99	2728	1.39	34000	1 1 2		
12	120.31	3055	1.24	34000	1 2 5		
11	128.92	3272	1.29	34000	1 4 0		
10	144.96	3667	1.15	34000	1 6 0		
8.9	160.93	4033	0.94	34000	K 0 9 5 1 1 6 0 _ M _ _ _ _ 4 . 0 A - -	231	112M
20	71.89	1839	3.91	43400	K 1 0 3 1 7 1 . _ M _ _ _ _ 4 . 0 A - -	324	112M
17	82.83	2121	3.39	43400	8 0 .		
17	86.53	2218	3.24	43400	9 0 .		
14	99.7	2549	2.82	43388	1 0 0		
13	112.03	2849	2.52	43388	1 1 2		
12	120.36	3065	2.35	43388	1 2 5		
11	134.85	3431	2.1	43301	1 4 0		
10	144.88	3683	1.95	43301	1 6 0		
8.6	166.84	4182	1.72	43100	K 1 0 5 1 1 6 0 _ M _ _ _ _ 4 . 0 A - -	356	112M
6.2	231.1	5793	1.24	43100	2 0 0		
5.5	259.6	6507	1.1	43100	2 5 0		
5	285.44	7156	1	43100	2 8 0		
4.5	317.19	7933	0.91	43100	3 2 0		
12	121.06	3095	3.91	61700	K 1 2 3 1 1 2 5 _ M _ _ _ _ 4 . 0 A - -	458	112M
10	137.09	3476	3.54	61700	1 4 0		
10	145.85	3710	3.32	61700	1 6 0		

NOTE

Other output speeds are available using 2 and 8 pole motors - Consult Application Engineering

SERIES K

SELECTION TABLES

GEARED MOTORS

4.0 kW	N2 R/MIN	i	M2 Nm	Fm	N	Unit Designation	Kg	Motor Size			
	Output Speed	Ratio	Output Torque	Service Factor	Overhung Load	Column Entry 1 Through 20 Spaces to be filled when entering order	Weight of base mount unit				
4 POLE	8.3	172.15	4325	2.8	61368	K 1 2 5 1 1 6 0 _ M _ _ _ _ 4 . 0 A - -	516	112M			
	5.3	268.79	6746	1.79	61368	2 0 0					
	6	238.46	5992	2.02	61368	2 5 0					
	4.8	301.94	7578	1.6	61368	2 8 0					
	4.3	331.99	8333	1.45	61368	3 2 0					
	3.7	384.7	9664	1.25	61368	3 6 0					
	3.3	437.38	10986	1.1	61368	4 0 0					
	2.9	493.02	12372	0.98	61368	4 5 0					
	2.7	531.11	13338	0.91	61368	5 0 0					
	2.5	584.22	14669	0.82	61368	5 6 0					
	4.0 kW	112	8.6	328	2.16	10232			K 0 7 3 2 8 . 0 _ M _ _ _ _ 4 . 0 C - -	115	132M
		81	11.91	456	2.16	10868			1 1 .		
72		13.37	513	2.16	11080	1 2 .					
65		14.71	564	2.16	11300	1 4 .					
50		19.21	736	1.98	11660	1 8 .					
44		21.84	838	1.81	11724	2 0 .					
36		26.52	1015	1.58	11820	2 5 .					
33		29.17	1118	1.43	11830	2 8 .					
29		33.52	1285	1.25	11256	3 2 .					
25		38.01	1454	1.1	10931	3 6 .					
23		41.92	1604	1	10606	4 0 .					
20		48.01	1833	0.87	9799	4 5 .					
52		18.41	707	3.55	14800	K 0 8 3 2 1 8 . _ M _ _ _ _ 4 . 0 C - -	171	132M			
46		20.67	793	3.28	15100	2 0 .					
38		25.35	974	2.75	16050	2 5 .					
34		28.56	1094	2.45	16362	2 8 .					
29		33.24	1273	2.11	16650	3 2 .					
26		36.88	1410	1.9	19200	3 6 .					
24		40.36	1544	1.74	19500	4 0 .					
21		45.66	1745	1.53	20000	4 5 .					
19		51.54	1970	1.36	15850	5 0 .					
15		62.47	2387	1.12	15008	6 3 .					
13		72.86	2777	0.96	14118	7 1 .					
12		80.03	3054	0.88	12971	8 0 .					
21		44.89	1718	2.2	34000	K 0 9 3 1 4 5 . _ M _ _ _ _ 4 . 0 C - -			224	132M	
19		49.87	1909	1.98	34000	5 0 .					
18		54.09	2063	2.04	34000	5 6 .					
16		60.1	2291	1.84	34000	6 3 .					
14		70.45	2690	1.4	34000	7 1 .					
12		77.78	2970	1.27	34000	8 0 .					
11		84.89	3232	1.3	34000	9 0 .					
10		93.71	3567	1.18	34000	1 0 0					
9		106.99	4075	0.93	34000	1 1 2					
8		120.31	4567	0.83	34000	1 2 5					
7.4		128.92	4895	0.86	34000	1 4 0					
18		54.61	2084	3.45	43400	K 1 0 3 1 5 6 . _ M _ _ _ _ 4 . 0 C - -	348	132M			
16		60.68	2319	3.1	43400	6 3 .					
13		71.89	2765	2.6	43400	7 1 .					
12		82.83	3167	2.27	43383	8 0 .					
11		86.53	3305	2.17	43383	9 0 .					
10		99.7	3804	1.89	43362	1 0 0					
8.6		112.03	4273	1.68	43400	1 1 2					
8		120.36	4586	1.57	43400	1 2 5					
7.1		134.85	5135	1.4	43230	1 4 0					
6.6		144.88	5509	1.3	43150	1 6 0					
5.8		166.84	6275	1.15	43100	K 1 0 5 1 1 6 0 _ M _ _ _ _ 4 . 0 C - -			379	132M	
4.2		231.1	8692	0.83	43100	2 0 0					
10		100.12	3784	3.25	61700	K 1 2 3 1 1 0 0 _ M _ _ _ _ 4 . 0 C - -			482	132M	
8.4		113.79	4321	2.8	61700	1 1 2					
7.9		121.06	4609	2.62	61693	1 2 5					
7		137.09	5211	2.36	61683	1 4 0					
6.6		145.85	5546	2.22	61700	1 6 0					
5.6	172.15	6481	1.87	61368	K 1 2 5 1 1 6 0 _ M _ _ _ _ 4 . 0 C - -	539	132M				
3.6	268.79	10111	1.2	61368	2 0 0						
4	238.46	8977	1.35	61368	2 5 0						
3.2	301.94	11357	1.06	61368	2 8 0						
2.9	331.99	12487	0.97	61368	3 2 0						
2.5	384.7	14474	0.84	61368	3 6 0						

NOTE
Other output speeds are available using 2 and 8 pole motors - Consult Application Engineering

SERIES K

SELECTION TABLES

GEARED MOTORS

5.5 kW

4 POLE

N2 R/MIN	i	M2 Nm	Fm	N	Unit Designation	Kg	Motor Size
Output Speed	Ratio	Output Torque	Service Factor	Overhung Load	Column Entry 1 Through 20 Spaces to be filled when entering order	Weight of base mount unit	
168	8.6	299	2.37	8915	K 0 7 3 2 8 . 0 _ M _ _ _ _ 5 . 5 A - -	111	132S
121	11.91	416	2.37	9444	1 1 .		
108	13.37	469	2.37	9575	1 2 .		
98	14.71	515	2.37	9705	1 4 .		
75	19.21	673	2	9965	1 8 .		
66	21.84	767	1.82	10027	2 0 .		
54	26.52	932	1.6	10127	2 5 .		
49	29.17	1025	1.49	10049	2 8 .		
43	33.52	1176	1.34	9935	3 2 .		
38	38.01	1332	1.2	9792	3 6 .		
34	41.92	1469	1.09	9600	4 0 .		
30	48.01	1681	0.95	9185	4 5 .		
27	54.28	1901	0.84	8717	5 0 .		
78	18.41	646	3.56	12711	K 0 8 3 2 1 8 . _ M _ _ _ _ 5 . 5 A - -	167	132S
70	20.67	723	3.25	12911	2 0 .		
57	25.35	889	2.74	14131	2 5 .		
50	28.56	1000	2.53	14477	2 8 .		
43	33.24	1164	2.28	14722	3 2 .		
39	36.88	1290	2.08	14227	3 6 .		
36	40.36	1413	1.9	14227	4 0 .		
32	45.66	1599	1.68	14227	4 5 .		
28	51.54	1805	1.48	13715	5 0 .		
23	62.47	2185	1.23	13387	6 3 .		
20	72.86	2545	1.05	12914	7 1 .		
18	80.03	2795	0.96	12524	8 0 .		
32	44.89	1574	2.4	34000	K 0 9 3 1 4 5 . _ M _ _ _ _ 5 . 5 A - -	220	132S
29	49.87	1744	2.17	34000	5 0 .		
27	54.09	1895	2.22	34000	5 6 .		
24	60.1	2100	2	34000	6 3 .		
20	70.45	2465	1.53	34000	7 1 .		
19	77.78	2722	1.39	34000	8 0 .		
17	84.89	2958	1.42	34000	9 0 .		
15	93.71	3265	1.29	34000	1 0 0		
13	106.99	3738	1.01	34000	1 1 2		
12	120.31	4186	0.9	34000	1 2 5		
11	128.92	4483	0.94	34000	1 4 0		
26	54.61	1914	3.76	43400	K 1 0 3 1 5 6 . _ M _ _ _ _ 5 . 5 A - -	344	132S
24	60.68	2129	3.38	43400	6 3 .		
20	71.89	2520	2.85	43400	7 1 .		
17	82.83	2906	2.47	43400	8 0 .		
17	86.53	3039	2.37	43400	9 0 .		
14	99.7	3492	2.06	43372	1 0 0		
13	112.03	3903	1.84	43372	1 1 2		
12	120.36	4200	1.71	43372	1 2 5		
11	134.85	4701	1.53	43215	1 4 0		
10	144.88	5046	1.42	43215	1 6 0		
8.6	166.84	5730	1.25	43100	K 1 0 5 1 1 6 0 _ M _ _ _ _ 5 . 5 A - -	375	132S
6.2	231.1	7938	0.91	43100	2 0 0		
5.5	259.6	8917	0.81	43100	2 5 0		
16	89.89	3124	3.94	61700	K 1 2 3 1 9 0 . _ M _ _ _ _ 5 . 5 A - -	478	132SA
14	100.12	3475	3.54	61700	1 0 0		
13	113.79	3965	3.05	61700	1 1 2		
12	121.06	4241	2.85	61700	1 2 5		
11	137.09	4763	2.58	61700	1 4 0		
10	145.85	5083	2.42	61700	1 6 0		
8.4	172.15	5927	2.04	61368	K 1 2 5 1 1 6 0 _ M _ _ _ _ 5 . 5 A - -	535	132SA
5.4	268.79	9244	1.31	61368	2 0 0		
6	238.46	8210	1.47	61368	2 5 0		
4.8	301.94	10384	1.16	61368	2 8 0		
4.3	331.99	11418	1.06	61368	3 2 0		
3.7	384.7	13242	0.91	61368	3 6 0		
3.3	437.38	15054	0.8	61368	4 0 0		

NOTE

Other output speeds are available using 2 and 8 pole motors - Consult Application Engineering

SERIES K

SELECTION TABLES

GEARED MOTORS

5.5 kW

6 POLE

N2 R/MIN	i	M2 Nm	Fm	N	Unit Designation	Kg	Motor Size
Output Speed	Ratio	Output Torque	Service Factor	Overhung Load	Column Entry 1 Through 20 Spaces to be filled when entering order	Weight of base mount unit	
112	8.6	452	1.57	9530	K 0 7 3 2 8 . 0 _ M _ _ _ _ 5 . 5 C - -	115	132M
81	11.91	627	1.57	9920	1 1 .		
72	13.37	705	1.57	10000	1 2 .		
65	14.71	775	1.57	10100	1 4 .		
50	19.21	1012	1.44	10100	1 8 .		
44	21.84	1153	1.32	9960	2 0 .		
36	26.52	1396	1.15	9670	2 5 .		
33	29.17	1538	1.04	9440	2 8 .		
29	33.52	1767	0.91	9010	3 2 .		
25	38.01	2000	0.8	8490	3 6 .		
118	8.13	426	3.16	12021	K 0 8 3 2 8 . 0 _ M _ _ _ _ 5 . 5 C - -	171	132M
83	11.52	606	3.16	13014	1 1 .		
75	12.8	673	3.16	13271	1 2 .		
67	14.24	752	3.11	13607	1 4 .		
52	18.41	972	2.58	14157	1 8 .		
46	20.67	1091	2.38	14392	2 0 .		
38	25.35	1340	2	15075	2 5 .		
34	28.56	1505	1.78	15256	2 8 .		
29	33.24	1750	1.53	15375	3 2 .		
26	36.88	1939	1.38	19200	3 6 .		
24	40.36	2123	1.26	19500	4 0 .		
21	45.66	2400	1.12	20000	4 5 .		
19	51.54	2709	0.99	12460	5 0 .		
15	62.47	3282	0.82	11113	6 3 .		
21	44.89	2362	1.6	34000	K 0 9 3 1 4 5 . _ M _ _ _ _ 5 . 5 C - -	224	132M
19	49.87	2625	1.44	34000	5 0 .		
18	54.09	2837	1.48	34000	5 6 .		
16	60.1	3150	1.34	34000	6 3 .		
14	70.45	3699	1.02	34000	7 1 .		
12	77.78	4084	0.93	34000	8 0 .		
11	84.89	4444	0.95	34000	9 0 .		
10	93.71	4905	0.86	34000	1 0 0		
21	45.37	2396	3	43400	K 1 0 3 1 4 5 . _ M _ _ _ _ 5 . 5 C - -	348	132M
19	50.41	2654	2.71	43400	5 0 .		
18	54.61	2865	2.51	43400	5 6 .		
16	60.68	3189	2.25	43391	6 3 .		
13	71.89	3802	1.89	43389	7 1 .		
12	82.83	4355	1.65	43358	8 0 .		
11	86.53	4545	1.58	43358	9 0 .		
10	99.7	5230	1.37	43306	1 0 0		
8.6	112.03	5875	1.22	43400	1 1 2		
8	120.36	6307	1.14	43400	1 2 5		
7.1	134.85	7061	1.02	43088	1 4 0		
6.6	144.88	7575	0.95	43000	1 6 0		
5.8	166.84	8629	0.83	43100	K 1 0 5 1 1 6 0 _ M _ _ _ _ 5 . 5 C - -	379	132M
13	74.62	3914	3.09	61700	K 1 2 3 1 7 1 . _ M _ _ _ _ 5 . 5 C - -	482	132M
12	83.1	4349	2.78	61700	8 0 .		
11	89.89	4697	2.62	61700	9 0 .		
10	100.12	5203	2.36	61700	1 0 0		
8.4	113.79	5941	2.04	61689	1 1 2		
7.9	121.06	6338	1.91	61683	1 2 5		
7	137.09	7166	1.72	61658	1 4 0		
6.6	145.85	7626	1.61	61700	1 6 0		
5.6	172.15	8911	1.36	61368	K 1 2 5 1 1 6 0 _ M _ _ _ _ 5 . 5 C - -	539	132M
3.6	268.79	13903	0.87	61368	2 0 0		
4	238.46	12343	0.98	61368	2 5 0		

7.5 kW

4 POLE

NOTE

Other output speeds are available using 2 and 8 pole motors - Consult Application Engineering

168	8.6	407	1.74	8295	K 0 7 3 2 8 . 0 _ M _ _ _ _ 7 . 5 A - -	115	132M
121	11.91	565	1.74	8570	1 1 .		
108	13.37	637	1.74	8610	1 2 .		
98	14.71	700	1.74	8645	1 4 .		
75	19.21	915	1.47	8585	1 8 .		
66	21.84	1043	1.34	8465	2 0 .		
54	26.52	1267	1.18	8204	2 5 .		
50	29.17	1394	1.1	7957	2 8 .		
43	33.52	1598	0.99	7532	3 2 .		
38	38.01	1810	0.88	7060	3 6 .		
34	41.92	1996	0.8	6570	4 0 .		

SERIES K

SELECTION TABLES

GEARED MOTORS

7.5 kW

4 POLE

N2 R/MIN	i	M2 Nm	Fm	N	Unit Designation	Kg	Motor Size
Output Speed	Ratio	Output Torque	Service Factor	Overhung Load	Column Entry <input type="text" value="1"/> Through <input type="text" value="20"/> Spaces to be filled when entering order	Weight of base mount unit	
178	8.13	386	3.49	10798	K 0 8 3 2 8 . 0 _ M _ _ _ _ 7 . 5 A - -	171	132M
125	11.52	549	3.49	11458	1 1 .		
113	12.8	611	3.32	11738	1 2 .		
101	14.24	676	3.15	11938	1 4 .		
78	18.41	878	2.62	12477	1 8 .		
70	20.67	982	2.39	12677	2 0 .		
57	25.35	1208	2.02	13640	2 5 .		
51	28.56	1360	1.86	13913	2 8 .		
43	33.24	1582	1.67	14086	3 2 .		
39	36.88	1753	1.53	13450	3 6 .		
36	40.36	1920	1.4	13450	4 0 .		
32	45.66	2173	1.23	13450	4 5 .		
28	51.54	2453	1.09	10600	5 0 .		
23	62.47	2970	0.9	9630	6 3 .		
32	44.89	2138	1.77	34000	K 0 9 3 1 4 5 . _ M _ _ _ _ 7 . 5 A - -	224	132M
29	49.87	2370	1.59	34000	5 0 .		
27	54.09	2575	1.63	34000	5 6 .		
24	60.1	2854	1.47	34000	6 3 .		
21	70.45	3350	1.13	34000	7 1 .		
19	77.78	3699	1.02	34000	8 0 .		
17	84.89	4020	1.05	34000	9 0 .		
15	93.71	4437	0.95	34000	1 0 0		
32	45.37	2164	3.32	35600	K 1 0 3 1 4 5 . _ M _ _ _ _ 7 . 5 A - -	348	132M
29	50.41	2404	2.99	35600	5 0 .		
26	54.61	2601	2.76	43400	5 6 .		
24	60.68	2893	2.48	43400	6 3 .		
20	71.89	3424	2.1	43400	7 1 .		
17	82.83	3949	1.82	43400	8 0 .		
17	86.53	4130	1.74	43400	9 0 .		
14	99.7	4746	1.51	43350	1 0 0		
13	112.03	5305	1.36	43350	1 1 2		
12	120.36	5707	1.26	43350	1 2 5		
11	134.85	6388	1.13	43100	1 4 0		
10	144.88	6858	1.05	43100	1 6 0		
8.7	166.84	7787	0.92	43100	K 1 0 5 1 1 6 0 _ M _ _ _ _ 7 . 5 A - -	379	132M
19	74.62	3543	3.41	61700	K 1 2 3 1 7 1 . _ M _ _ _ _ 7 . 5 A - -	482	132M
17	83.1	3942	3.07	61700	8 0 .		
16	89.89	4246	2.9	61700	9 0 .		
14	100.12	4722	2.6	61700	1 0 0		
13	113.79	5388	2.25	61700	1 1 2		
12	121.06	5763	2.1	61700	1 2 5		
11	137.09	6473	1.9	61700	1 4 0		
10	145.85	6908	1.78	61700	1 6 0		
8.4	172.15	8054	1.5	61368	K 1 2 5 1 1 6 0 _ M _ _ _ _ 7 . 5 A - -	539	132M
5.4	268.79	12563	0.96	61368	2 0 0		
6.1	238.46	11157	1.08	61368	2 5 0		
4.8	301.94	14112	0.86	61368	2 8 0		

7.5 kW

6 POLE

118	8.13	581	2.32	11650	K 0 8 3 2 8 . 0 _ M _ _ _ _ 7 . 5 C - -	205	160M
83	11.52	827	2.32	12500	1 1 .		
75	12.8	918	2.32	12700	1 2 .		
67	14.24	1026	2.28	12950	1 4 .		
52	18.41	1325	1.89	13300	1 8 .		
46	20.67	1488	1.75	13450	2 0 .		
38	25.35	1827	1.47	13775	2 5 .		
34	28.56	2053	1.31	13781	2 8 .		
29	33.24	2387	1.12	13675	3 2 .		
26	36.88	2644	1.01	19200	3 6 .		
24	40.36	2896	0.93	19500	4 0 .		
21	45.66	3273	0.82	20000	4 5 .		
64	14.94	1071	3.76	34000	K 0 9 3 1 1 6 . _ M _ _ _ _ 7 . 5 C - -	258	160M
54	17.93	1285	2.89	34000	1 8 .		
48	20.03	1435	2.63	34000	2 0 .		
44	21.61	1547	2.72	34000	2 2 .		
40	24.14	1725	2.44	34000	2 5 .		
35	27.78	1996	1.89	34000	2 8 .		
30	31.67	2268	1.67	34000	3 2 .		
29	33.47	2392	1.76	34000	3 6 .		
25	38.16	2721	1.55	34000	4 0 .		
21	44.89	3221	1.17	34000	4 5 .		
19	49.87	3579	1.06	34000	5 0 .		
18	54.09	3869	1.09	34000	5 6 .		
16	60.1	4295	0.98	34000	6 3 .		

NOTE

Other output speeds are available using 2 and 8 pole motors - Consult Application Engineering

SERIES K

SELECTION TABLES

GEARED MOTORS

	N2 R/MIN	i	M2 Nm	Fm	N	Unit Designation	Kg	Motor Size				
	Output Speed	Ratio	Output Torque	Service Factor	Overhung Load	Column Entry 1 Through 20 Spaces to be filled when entering order	Weight of base mount unit					
7.5 kW	6 POLE											
	29	33.1	2386	3.01	35600	K 1 0 3 1 3 2 . _ M _ _ _ _ 7 . 5 C - -	382	160M				
	27	35.19	2531	2.84	35600	3 6 .						
	24	39.84	2868	2.51	35600	4 0 .						
	21	45.37	3268	2.2	43400	4 5 .						
	19	50.41	3619	1.99	43400	5 0 .						
	18	54.61	3907	1.84	43400	5 6 .						
	16	60.68	4348	1.65	43380	6 3 .						
	13	71.89	5185	1.39	43375	7 1 .						
	12	82.83	5938	1.21	43325	8 0 .						
	11	86.53	6198	1.16	43325	9 0 .						
	10	99.7	7132	1.01	43231	1 0 0						
	8.6	112.03	8012	0.9	43400	1 1 2						
	8	120.36	8600	0.84	43400	1 2 5						
	18	52.76	3781	3.2	61700	K 1 2 3 1 5 0 . _ M _ _ _ _ 7 . 5 C - -			517	160M		
	17	56.39	4028	3.05	61700	5 6 .						
	15	63.57	4544	2.71	61700	6 3 .						
	13	74.62	5338	2.27	61700	7 1 .						
	12	83.1	5931	2.04	61700	8 0 .						
	11	89.89	6406	1.92	61700	9 0 .						
	10	100.12	7096	1.73	61700	1 0 0						
	8.4	113.79	8102	1.49	61675	1 1 2						
	7.9	121.06	8642	1.4	61670	1 2 5						
	7	137.09	9772	1.26	61625	1 4 0						
	6.6	145.85	10400	1.18	61700	1 6 0						
	9.0 kW	4 POLE										
		168	8.6	501	1.41	7768	K 0 7 3 2 8 . 0 _ M _ _ _ _ 9 . 2 K - -	141			132M	
		121	11.91	696	1.41	7826	1 1 .					
108		13.37	784	1.41	7789	1 2 .						
98		14.71	862	1.41	7744	1 4 .						
75		19.21	1126	1.2	7412	1 8 .						
66		21.84	1284	1.09	7136	2 0 .						
54		26.52	1559	0.96	6570	2 5 .						
49		29.17	1715	0.89	6180	2 8 .						
43		33.52	1967	0.8	5490	3 2 .						
8.4	172.15	9914	1.22	61368	K 1 2 5 1 1 6 0 _ M _ _ _ _ 9 . 2 K - -	565	132M					
6	238.46	13734	0.88	61368	2 5 0							
11.0 kW	4 POLE											
	178	8.13	564	2.39	10612	K 0 8 3 2 8 . 0 _ M _ _ _ _ 1 1 . A - -	205	160M				
	126	11.52	803	2.39	11197	1 1 .						
	113	12.8	893	2.27	11440	1 2 .						
	102	14.24	988	2.15	11640	1 4 .						
	79	18.41	1284	1.79	12068	1 8 .						
	70	20.67	1436	1.64	12268	2 0 .						
	57	25.35	1765	1.38	12781	2 5 .						
	51	28.56	1987	1.27	12927	2 8 .						
	44	33.24	2313	1.15	12972	3 2 .						
	39	36.88	2563	1.05	12088	3 6 .						
	36	40.36	2807	0.95	12088	4 0 .						
	32	45.66	3176	0.84	12088	4 5 .						
	131	11.06	768	3.89	34000	K 0 9 3 1 1 1 . _ M _ _ _ _ 1 1 . A - -			258	160M		
	117	12.4	860	3.64	34000	1 2 .						
	109	13.33	925	3.89	34000	1 4 .						
	97	14.94	1036	3.64	34000	1 6 .						
	81	17.93	1250	2.78	34000	1 8 .						
	72	20.03	1393	2.55	34000	2 0 .						
	67	21.61	1501	2.76	34000	2 2 .						
	60	24.14	1677	2.51	34000	2 5 .						
	52	27.78	1928	1.95	34000	2 8 .						
	46	31.67	2211	1.71	34000	3 2 .						
	43	33.47	2327	1.81	34000	3 6 .						
	38	38.16	2646	1.59	34000	4 0 .						
	32	44.89	3126	1.21	34000	4 5 .						
	29	49.87	3465	1.09	34000	5 0 .						
	27	54.09	3765	1.12	34000	5 6 .						
24	60.1	4172	1.01	34000	6 3 .							
44	33.1	2312	3.11	35604	K 1 0 3 1 3 2 . _ M _ _ _ _ 1 1 . A - -	382	160M					
41	35.19	2456	2.93	35604	3 6 .							
36	39.84	2775	2.59	35605	4 0 .							
32	45.37	3163	2.27	35584	4 5 .							
29	50.41	3515	2.05	35575	5 0 .							
27	54.61	3802	1.89	43400	5 6 .							
24	60.68	4229	1.7	43400	6 3 .							
20	71.89	5005	1.44	43400	7 1 .							
18	82.83	5772	1.25	43400	8 0 .							
17	86.53	6037	1.19	43400	9 0 .							
15	99.7	6937	1.04	43311	1 0 0							
13	112.03	7753	0.93	43311	1 1 2							
12	120.36	8342	0.86	43311	1 2 5							

NOTE
Other output speeds are available using 2 and 8 pole motors - Consult Application Engineering

SERIES K

SELECTION TABLES

GEARED MOTORS

11.0 kW

4 POLE

N2 R/MIN	i	M2 Nm	Fm	N	Unit Designation	Kg	
Output Speed	Ratio	Output Torque	Service Factor	Overhung Load	Column Entry 1 Through 20 Spaces to be filled when entering order	Weight of base mount unit	Motor Size
31	46.81	3262	3.71	61800	K 1 2 3 1 4 5 . _ M _ _ _ _ 1 1 . A - -	517	160M
27	52.76	3676	3.29	61800	5 0 .		
26	56.39	3910	3.15	61832	5 6 .		
23	63.57	4407	2.79	61832	6 3 .		
19	74.62	5178	2.34	61186	7 1 .		
17	83.1	5761	2.1	61186	8 0 .		
16	89.89	6206	1.98	61700	9 0 .		
14	100.12	6903	1.78	61700	1 0 0		
13	113.79	7875	1.54	61700	1 1 2		
12	121.06	8424	1.44	61700	1 2 5		
11	137.09	9461	1.3	61700	1 4 0		
10	145.85	10097	1.22	61700	1 6 0		

11.0 kW

6 POLE

119	8.13	849	1.59	11000	K 0 8 3 2 8 . 0 _ M _ _ _ _ 1 1 . C - -	219	160L
84	11.52	1207	1.59	11600	1 1 .		
75	12.8	1339	1.59	11700	1 2 .		
68	14.24	1497	1.56	11800	1 4 .		
52	18.41	1934	1.3	11800	1 8 .		
47	20.67	2171	1.2	11800	2 0 .		
38	25.35	2666	1.01	11500	2 5 .		
34	28.56	2995	0.89	11200	2 8 .		
120	8.03	842	3.45	34000	K 0 9 3 1 8 . 0 _ M _ _ _ _ 1 1 . C - -		
100	9.68	1013	3.45	34000	1 0 .		
87	11.06	1158	2.8	34000	1 1 .		
78	12.4	1299	2.58	34000	1 2 .		
72	13.33	1394	2.8	34000	1 4 .		
65	14.94	1563	2.58	34000	1 6 .		
54	17.93	1875	1.98	34000	1 8 .		
48	20.03	2094	1.8	34000	2 0 .		
45	21.61	2258	1.86	34000	2 2 .		
40	24.14	2517	1.67	34000	2 5 .		
35	27.78	2912	1.3	34000	2 8 .		
30	31.67	3309	1.14	34000	3 2 .		
29	33.47	3490	1.21	34000	3 6 .		
25	38.16	3971	1.06	34000	4 0 .		
21	44.89	4700	0.8	34000	4 5 .		
43	22.35	2341	3.07	35600	K 1 0 3 1 2 2 . _ M _ _ _ _ 1 1 . C - -		
40	24.13	2529	2.84	35600	2 5 .		
33	29.24	3073	2.34	35600	2 8 .		
29	33.1	3481	2.07	35553	3 2 .		
27	35.19	3693	1.95	35553	3 6 .		
24	39.84	4185	1.72	35553	4 0 .		
21	45.37	4768	1.51	43400	4 5 .		
19	50.41	5280	1.36	43400	5 0 .		
18	54.61	5701	1.26	43400	5 6 .		
16	60.68	6345	1.13	43361	6 3 .		
13	71.89	7565	0.95	43351	7 1 .		
12	82.83	8665	0.83	43266	8 0 .		
28	34.93	3657	3.36	61700	K 1 2 3 1 3 6 . _ M _ _ _ _ 1 1 . C - -		
24	39.55	4141	2.97	61700	4 0 .		
21	46.81	4904	2.47	61700	4 5 .		
18	52.76	5517	2.19	61672	5 0 .		
17	56.39	5877	2.09	61664	5 6 .		
15	63.57	6630	1.86	61664	6 3 .		
13	74.62	7788	1.55	61700	7 1 .		
12	83.1	8654	1.4	61700	8 0 .		
11	89.89	9347	1.32	61700	9 0 .		
10	100.12	10353	1.19	61700	1 0 0		
8.5	113.79	11822	1.02	61651	1 1 2		
8	121.06	12610	0.96	61648	1 2 5		
7	137.09	14258	0.86	61566	1 4 0		
6.6	145.85	15174	0.81	61700	1 6 0		

NOTE

Other output speeds are available using 2 and 8 pole motors - Consult Application Engineering

SERIES K

SELECTION TABLES

GEARED MOTORS

15.0 kW

4 POLE

N2 R/MIN	i	M2 Nm	Fm	N	Unit Designation	Kg	Motor Size
Output Speed	Ratio	Output Torque	Service Factor	Overhung Load	Column Entry 1 Through 20 Spaces to be filled when entering order	Weight of base mount unit	
179	8.13	767	1.76	10400	K 0 8 3 2 8 . 0 _ M _ _ _ _ 1 5 . A - -	219	160L
126	11.52	1091	1.76	10900	1 1 .		
114	12.8	1213	1.67	11100	1 2 .		
102	14.24	1343	1.59	11300	1 4 .		
79	18.41	1745	1.32	11600	1 8 .		
70	20.67	1951	1.2	11800	2 0 .		
57	25.35	2399	1.02	11800	2 5 .		
51	28.56	2701	0.94	11800	2 8 .		
44	33.24	3143	0.84	11700	3 2 .		
181	8.03	757	3.39	34000	K 0 9 3 1 8 . 0 _ M _ _ _ _ 1 5 . A - -	272	160L
150	9.68	914	3.39	34000	1 0 .		
132	11.06	1044	2.86	34000	1 1 .		
117	12.4	1169	2.68	34000	1 2 .		
109	13.33	1257	2.86	34000	1 4 .		
97	14.94	1408	2.68	34000	1 6 .		
81	17.93	1700	2.05	34000	1 8 .		
73	20.03	1893	1.88	34000	2 0 .		
67	21.61	2040	2.03	34000	2 2 .		
60	24.14	2280	1.85	34000	2 5 .		
52	27.78	2621	1.44	34000	2 8 .		
46	31.67	3005	1.26	34000	3 2 .		
43	33.47	3162	1.33	34000	3 6 .		
38	38.16	3596	1.17	34000	4 0 .		
32	44.89	4248	0.89	34000	4 5 .		
29	49.87	4708	0.8	34000	5 0 .		
27	54.09	5116	0.82	34000	5 6 .		
73	20.05	1901	3.77	35600	K 1 0 3 1 2 0 . _ M _ _ _ _ 1 5 . A - -	396	160L
65	22.35	2115	3.4	35600	2 2 .		
60	24.13	2281	3.15	35600	2 5 .		
50	29.24	2777	2.59	35600	2 8 .		
44	33.1	3142	2.29	35588	3 2 .		
41	35.19	3337	2.15	35588	3 6 .		
37	39.84	3771	1.91	35583	4 0 .		
32	45.37	4299	1.67	35566	4 5 .		
29	50.41	4776	1.51	35548	5 0 .		
27	54.61	5167	1.39	43400	5 6 .		
24	60.68	5747	1.25	43400	6 3 .		
20	71.89	6802	1.06	43400	7 1 .		
18	82.83	7845	0.92	43400	8 0 .		
17	86.53	8204	0.88	43400	9 0 .		
44	32.83	3118	3.88	61700	K 1 2 3 1 3 2 . _ M _ _ _ _ 1 5 . A - -	531	160L
42	34.93	3301	3.73	61469	3 6 .		
37	39.55	3744	3.28	61469	4 0 .		
31	46.81	4433	2.73	61400	4 5 .		
28	52.76	4996	2.42	61400	5 0 .		
26	56.39	5314	2.31	61304	5 6 .		
23	63.57	5989	2.05	61304	6 3 .		
19	74.62	7037	1.72	60600	7 1 .		
18	83.1	7830	1.55	60600	8 0 .		
16	89.89	8434	1.46	61700	9 0 .		
15	100.12	9380	1.31	61700	1 0 0		
13	113.79	10702	1.13	61700	1 1 2		
12	121.06	11447	1.06	61700	1 2 5		
11	137.09	12857	0.96	61700	1 4 0		
10	145.85	13721	0.9	61700	1 6 0		

15.0 kW

6 POLE

121	8.03	1142	2.55	34000	K 0 9 3 1 8 . 0 _ M _ _ _ _ 1 5 . C - -	371	180L
100	9.68	1374	2.55	34000	1 0 .		
88	11.06	1571	2.06	34000	1 1 .		
78	12.4	1763	1.9	34000	1 2 .		
73	13.33	1892	2.06	34000	1 4 .		
65	14.94	2121	1.9	34000	1 6 .		
54	17.93	2544	1.46	34000	1 8 .		
48	20.03	2840	1.33	34000	2 0 .		
45	21.61	3063	1.37	34000	2 2 .		
40	24.14	3415	1.23	34000	2 5 .		
35	27.78	3951	0.96	34000	2 8 .		
31	31.67	4489	0.84	34000	3 2 .		
29	33.47	4734	0.89	34000	3 6 .		
70	13.89	1974	3.49	35600	K 1 0 3 1 1 4 . _ M _ _ _ _ 1 5 . C - -	495	180L
64	15.11	2147	3.35	35600	1 6 .		
52	18.57	2648	2.71	35600	1 8 .		
48	20.05	2853	2.52	35600	2 0 .		
43	22.35	3176	2.26	35536	2 2 .		
40	24.13	3432	2.09	35536	2 5 .		
33	29.24	4169	1.72	35536	2 8 .		
29	33.1	4722	1.52	35500	3 2 .		
28	35.19	5011	1.43	35500	3 6 .		
24	39.84	5677	1.27	35500	4 0 .		
21	45.37	6468	1.11	43400	4 5 .		
19	50.41	7163	1	43400	5 0 .		
18	54.61	7734	0.93	43400	5 6 .		
16	60.68	8607	0.84	43338	6 3 .		

NOTE

Other output speeds are available using 2 and 8 pole motors - Consult Application Engineering

SERIES K

SELECTION TABLES

GEARED MOTORS

15.0 kW

6 POLE

N2 R/MIN	i	M2 Nm	Fm	N	Unit Designation	Kg	Motor Size
Output Speed	Ratio	Output Torque	Service Factor	Overhung Load	Column Entry [1] Through [20] Spaces to be filled when entering order	Weight of base mount unit	
33	28.99	4129	2.93	61700	K 1 2 3 1 2 8 . _ M _ _ _ _ 1 5 . C - -	629	180L
30	32.83	4677	2.59	61700	3 2 .		
28	34.93	4961	2.48	61672	3 6 .		
25	39.55	5618	2.19	61672	4 0 .		
21	46.81	6652	1.82	61664	4 5 .		
18	52.76	7484	1.62	61640	5 0 .		
17	56.39	7973	1.54	61623	5 6 .		
15	63.57	8994	1.37	61623	6 3 .		
13	74.62	10566	1.15	61700	7 1 .		
12	83.1	11740	1.03	61700	8 0 .		
11	89.89	12680	0.97	61700	9 0 .		
10	100.12	14045	0.88	61700	1 0 0		

18.5 kW

4 POLE

183	8.03	925	2.78	34000	K 0 9 3 1 8 . 0 _ M _ _ _ _ 1 8 . A - -	357	180M		
152	9.68	1115	2.78	34000	1 0 .				
133	11.06	1274	2.35	34000	1 1 .				
119	12.4	1427	2.19	34000	1 2 .				
110	13.33	1534	2.35	34000	1 4 .				
98	14.94	1719	2.19	34000	1 6 .				
82	17.93	2075	1.68	34000	1 8 .				
73	20.03	2311	1.54	34000	2 0 .				
68	21.61	2491	1.67	34000	2 2 .				
61	24.14	2783	1.51	34000	2 5 .				
53	27.78	3199	1.18	34000	2 8 .				
46	31.67	3669	1.03	34000	3 2 .				
44	33.47	3860	1.09	34000	3 6 .				
39	38.16	4390	0.96	34000	4 0 .				
79	18.57	2151	3.27	35600	K 1 0 3 1 1 8 . 0 _ M _ _ _ _ 1 8 . A - -			481	180M
73	20.05	2320	3.09	35588	2 0 .				
66	22.35	2582	2.78	35588	2 2 .				
61	24.13	2785	2.58	35588	2 5 .				
50	29.24	3390	2.12	35588	2 8 .				
44	33.1	3836	1.87	35574	3 2 .				
42	35.19	4074	1.76	35574	3 6 .				
37	39.84	4603	1.56	35563	4 0 .				
32	45.37	5248	1.37	35551	4 5 .				
29	50.41	5831	1.23	35524	5 0 .				
27	54.61	6307	1.14	43400	5 6 .				
24	60.68	7016	1.02	43400	6 3 .				
20	71.89	8304	0.87	43400	7 1 .				
45	32.83	3806	3.18	61507	K 1 2 3 1 3 2 . _ M _ _ _ _ 1 8 . A - -	615	180M		
42	34.93	4029	3.05	61201	3 6 .				
37	39.55	4571	2.69	61201	4 0 .				
31	46.81	5411	2.24	61050	4 5 .				
28	52.76	6099	1.98	61050	5 0 .				
26	56.39	6487	1.9	60842	5 6 .				
23	63.57	7311	1.68	60842	6 3 .				
20	74.62	8591	1.41	60086	7 1 .				
18	83.1	9558	1.27	60086	8 0 .				
16	89.89	10296	1.19	61700	9 0 .				
15	100.12	11451	1.07	61700	1 0 0				
13	113.79	13065	0.93	61700	1 1 2				
12	121.06	13974	0.87	61700	1 2 5				

18.5 kW

6 POLE

121	8.03	1402	2.08	34000	K 0 9 3 1 8 . 0 _ M _ _ _ _ 1 8 . C - -	426	200L		
101	9.68	1686	2.08	34000	1 0 .				
88	11.06	1928	1.68	34000	1 1 .				
79	12.4	2163	1.55	34000	1 2 .				
73	13.33	2321	1.68	34000	1 4 .				
65	14.94	2603	1.55	34000	1 6 .				
54	17.93	3122	1.19	34000	1 8 .				
49	20.03	3485	1.08	34000	2 0 .				
45	21.61	3759	1.12	34000	2 2 .				
40	24.14	4190	1	34000	2 5 .				
118	8.26	1441	2.84	35600	K 1 0 3 1 8 . 0 _ M _ _ _ _ 1 8 . C - -			550	200L
98	9.95	1730	2.84	35600	1 0 .				
84	11.54	2014	2.84	35600	1 1 .				
78	12.55	2194	2.84	35600	1 2 .				
70	13.89	2422	2.84	35530	1 4 .				
65	15.11	2635	2.73	35530	1 6 .				
53	18.57	3249	2.21	35530	1 8 .				
49	20.05	3501	2.05	35530	2 0 .				
44	22.35	3897	1.84	35481	2 2 .				
40	24.13	4211	1.71	35481	2 5 .				
33	29.24	5115	1.41	35481	2 8 .				
29	33.1	5795	1.24	35453	3 2 .				
28	35.19	6148	1.17	35453	3 6 .				
24	39.84	6966	1.03	35453	4 0 .				
21	45.37	7937	0.91	43400	4 5 .				
19	50.41	8789	0.82	43400	5 0 .				

NOTE

Other output speeds are available using 2 and 8 pole motors - Consult Application Engineering

SERIES K

SELECTION TABLES

GEARED MOTORS

18.5 kW

6 POLE

N2 R/MIN	i	M2 Nm	Fm	N	Unit Designation	Kg	
Output Speed	Ratio	Output Torque	Service Factor	Overhung Load	Column Entry 1 Through 20 Spaces to be filled when entering order	Weight of base mount unit	Motor Size
115	8.51	1484	3.41	61700	K 1 2 3 1 8 . 0 _ M _ _ _ _ 1 8 . C - -	685	200L
95	10.26	1783	3.41	61700	1 0 .		
83	11.8	2059	3.41	61700	1 1 .		
75	12.96	2264	3.41	61700	1 2 .		
69	14.21	2475	3.41	61700	1 4 .		
62	15.61	2722	3.41	61700	1 6 .		
54	18.2	3167	3.41	61700	1 8 .		
48	20.17	3519	3.41	61700	2 0 .		
44	21.93	3823	3.22	61700	2 2 .		
40	24.29	4235	2.9	61700	2 5 .		
34	28.99	5066	2.39	61673	2 8 .		
30	32.83	5739	2.11	61673	3 2 .		
28	34.93	6088	2.02	61648	3 6 .		
25	39.55	6893	1.78	61648	4 0 .		
21	46.81	8163	1.48	61633	4 5 .		
18	52.76	9183	1.32	61612	5 0 .		
17	56.39	9783	1.26	61588	5 6 .		
15	63.57	11036	1.11	61588	6 3 .		
13	74.62	12965	0.93	61700	7 1 .		
12	83.1	14405	0.84	61700	8 0 .		

22.0 kW

4 POLE

183	8.03	1100	2.34	34000	K 0 9 3 1 8 . 0 _ M _ _ _ _ 2 2 . A - -	371	180L
152	9.68	1326	2.34	34000	1 0 .		
133	11.06	1516	1.97	34000	1 1 .		
119	12.4	1698	1.84	34000	1 2 .		
110	13.33	1825	1.97	34000	1 4 .		
98	14.94	2045	1.84	34000	1 6 .		
82	17.93	2467	1.41	34000	1 8 .		
73	20.03	2749	1.29	34000	2 0 .		
68	21.61	2962	1.4	34000	2 2 .		
61	24.14	3310	1.27	34000	2 5 .		
53	27.78	3805	0.99	34000	2 8 .		
46	31.67	4363	0.87	34000	3 2 .		
44	33.47	4590	0.92	34000	3 6 .		
178	8.26	1134	3.6	35600	K 1 0 3 1 8 . 0 _ M _ _ _ _ 2 2 . A - -	495	180L
148	9.95	1365	3.6	35600	1 0 .		
127	11.54	1590	3.6	35600	1 1 .		
117	12.55	1727	3.57	35600	1 2 .		
106	13.89	1909	3.6	35600	1 4 .		
97	15.11	2077	3.46	35586	1 6 .		
79	18.57	2559	2.75	35586	1 8 .		
73	20.05	2759	2.59	35576	2 0 .		
66	22.35	3071	2.34	35576	2 2 .		
61	24.13	3312	2.17	35576	2 5 .		
50	29.24	4031	1.78	35576	2 8 .		
44	33.1	4562	1.58	35560	3 2 .		
42	35.19	4845	1.48	35560	3 6 .		
32	45.37	6241	1.15	35535	4 5 .		
29	50.41	6934	1.04	35500	5 0 .		
27	54.61	7501	0.96	43400	5 6 .		
24	60.68	8343	0.86	43400	6 3 .		
61	24.29	3340	3.68	61700	K 1 2 3 1 2 5 . _ M _ _ _ _ 2 2 . A - -	629	180L
51	28.99	3996	3.03	61700	2 8 .		
45	32.83	4527	2.67	61315	3 2 .		
42	34.93	4792	2.57	60932	3 6 .		
37	39.55	5436	2.26	60932	4 0 .		
31	46.81	6435	1.88	60700	4 5 .		
28	52.76	7253	1.67	60700	5 0 .		
26	56.39	7714	1.59	60380	5 6 .		
23	63.57	8694	1.41	60380	6 3 .		
20	74.62	10217	1.18	59573	7 1 .		
18	83.1	11367	1.06	59573	8 0 .		
16	89.89	12243	1	61700	9 0 .		
15	100.12	13618	0.9	61700	1 0 0		

NOTE

Other output speeds are available using 2 and 8 pole motors - Consult Application Engineering

SERIES K

SELECTION TABLES

GEARED MOTORS

22.0 kW

6 POLE

N2 R/MIN	i	M2 Nm	Fm	N	Unit Designation	Kg	Motor Size
Output Speed	Ratio	Output Torque	Service Factor	Overhung Load	Column Entry 1 Through 20 Spaces to be filled when entering order	Weight of base mount unit	
121	8.03	1667	1.75	34000	K 0 9 3 1 8 . 0 _ M _ _ _ _ 2 2 . C - -	426	200L
101	9.68	2005	1.75	34000	1 0 .		
88	11.06	2293	1.41	34000	1 1 .		
79	12.4	2573	1.3	34000	1 2 .		
73	13.33	2760	1.41	34000	1 4 .		
65	14.94	3095	1.3	34000	1 6 .		
54	17.93	3713	1	34000	1 8 .		
49	20.03	4145	0.91	34000	2 0 .		
45	21.61	4470	0.94	34000	2 2 .		
40	24.14	4983	0.84	34000	2 5 .		
118	8.26	1714	2.39	35508	K 1 0 3 1 8 . 0 _ M _ _ _ _ 2 2 . C - -	550	200L
98	9.95	2057	2.39	35508	1 0 .		
84	11.54	2396	2.39	35508	1 1 .		
78	12.55	2609	2.39	35508	1 2 .		
70	13.89	2881	2.39	35460	1 4 .		
65	15.11	3133	2.29	35460	1 6 .		
53	18.57	3864	1.86	35460	1 8 .		
49	20.05	4164	1.73	35460	2 0 .		
44	22.35	4635	1.55	35426	2 2 .		
40	24.13	5007	1.44	35426	2 5 .		
33	29.24	6083	1.18	35426	2 8 .		
29	33.1	6891	1.04	35406	3 2 .		
28	35.19	7312	0.98	35406	3 6 .		
115	8.51	1765	2.87	61700	K 1 2 3 1 8 . 0 _ M _ _ _ _ 2 2 . C - -	685	200L
95	10.26	2120	2.87	61700	1 0 .		
83	11.8	2448	2.87	61700	1 1 .		
75	12.96	2692	2.87	61700	1 2 .		
69	14.21	2944	2.87	61700	1 4 .		
62	15.61	3237	2.87	61690	1 6 .		
54	18.2	3767	2.87	61680	1 8 .		
48	20.17	4185	2.87	61671	2 0 .		
44	21.93	4546	2.71	61671	2 2 .		
40	24.29	5036	2.44	61671	2 5 .		
34	28.99	6025	2.01	61647	2 8 .		
30	32.83	6825	1.77	61647	3 2 .		
28	34.93	7240	1.7	61625	3 6 .		
25	39.55	8198	1.5	61625	4 0 .		
21	46.81	9707	1.25	61602	4 5 .		
18	52.76	10921	1.11	61584	5 0 .		
17	56.39	11634	1.06	61552	5 6 .		
15	63.57	13124	0.94	61552	6 3 .		

30.0 kW

4 POLE

183	8.03	1500	1.71	34000	K 0 9 3 1 8 . 0 _ M _ _ _ _ 3 0 . A - -	426	200L
152	9.68	1809	1.71	34000	1 0 .		
133	11.06	2067	1.45	34000	1 1 .		
119	12.4	2315	1.35	34000	1 2 .		
110	13.33	2489	1.45	34000	1 4 .		
98	14.94	2789	1.35	34000	1 6 .		
82	17.93	3365	1.03	34000	1 8 .		
73	20.03	3749	0.95	34000	2 0 .		
68	21.61	4039	1.03	34000	2 2 .		
61	24.14	4513	0.93	34000	2 5 .		
178	8.26	1547	2.64	35565	K 1 0 3 1 8 . 0 _ M _ _ _ _ 3 0 . A - -	550	200L
148	9.95	1861	2.64	35565	1 0 .		
127	11.54	2168	2.64	35565	1 1 .		
117	12.55	2355	2.62	35565	1 2 .		
106	13.89	2603	2.64	35565	1 4 .		
97	15.11	2833	2.54	35556	1 6 .		
79	18.57	3489	2.02	35556	1 8 .		
73	20.05	3763	1.9	35550	2 0 .		
66	22.35	4188	1.72	35550	2 2 .		
61	24.13	4517	1.59	35550	2 5 .		
50	29.24	5497	1.31	35550	2 8 .		
44	33.1	6221	1.16	35528	3 2 .		
42	35.19	6607	1.09	35528	3 6 .		
37	39.84	7465	0.96	35500	4 0 .		
173	8.51	1596	3.17	61700	K 1 2 3 1 8 . 0 _ M _ _ _ _ 3 0 . A - -	685	200L
143	10.26	1918	3.17	61700	1 0 .		
125	11.8	2214	3.17	61700	1 1 .		
113	12.96	2435	3.17	61700	1 2 .		
103	14.21	2662	3.17	61700	1 4 .		
94	15.61	2927	3.17	61700	1 6 .		
81	18.2	3407	3.17	61700	1 8 .		
73	20.17	3787	3.12	61700	2 0 .		
67	21.93	4112	2.99	61700	2 2 .		
61	24.29	4555	2.7	61311	2 5 .		
51	28.99	5449	2.22	61311	2 8 .		
45	32.83	6173	1.96	60875	3 2 .		
42	34.93	6534	1.88	60318	3 6 .		
37	39.55	7413	1.66	60318	4 0 .		
31	46.81	8776	1.38	59900	4 5 .		
28	52.76	9891	1.22	59900	5 0 .		
26	56.39	10519	1.17	59324	5 6 .		
23	63.57	11856	1.04	59324	6 3 .		
20	74.62	13932	0.87	58400	7 1 .		

NOTE

Other output speeds are available using 2 and 8 pole motors - Consult Application Engineering

SERIES K

SELECTION TABLES

GEARED MOTORS

30.0 kW

6 POLE

N2 R/MIN	i	M2 Nm	Fm	N	Unit Designation	Kg	Motor Size
Output Speed	Ratio	Output Torque	Service Factor	Overhung Load	Column Entry <input type="text" value="1"/> Through <input type="text" value="20"/> Spaces to be filled when entering order	Weight of base mount unit	
122	8.03	2262	1.29	34000	K 0 9 3 1 8 . 0 _ M _ _ _ _ 3 0 . C - -	520	225M
101	9.68	2721	1.29	34000	1 0 .		
89	11.06	3111	1.04	34000	1 1 .		
79	12.4	3491	0.96	34000	1 2 .		
74	13.33	3745	1.04	34000	1 4 .		
66	14.94	4199	0.96	34000	1 6 .		
119	8.26	2326	1.76	35300	K 1 0 3 1 8 . 0 _ M _ _ _ _ 3 0 . C - -	644	225M
99	9.95	2791	1.76	35300	1 0 .		
85	11.54	3250	1.76	35300	1 1 .		
78	12.55	3540	1.76	35300	1 2 .		
71	13.89	3908	1.76	35300	1 4 .		
65	15.11	4251	1.69	35300	1 6 .		
53	18.57	5243	1.37	35300	1 8 .		
49	20.05	5649	1.27	35300	2 0 .		
44	22.35	6288	1.14	35300	2 2 .		
41	24.13	6794	1.06	35300	2 5 .		
34	29.24	8253	0.87	35300	2 8 .		
115	8.51	2394	2.11	61700	K 1 2 3 1 8 . 0 _ M _ _ _ _ 3 0 . C - -	779	225M
96	10.26	2877	2.11	61700	1 0 .		
83	11.8	3322	2.11	61700	1 1 .		
76	12.96	3653	2.11	61700	1 2 .		
69	14.21	3994	2.11	61700	1 4 .		
63	15.61	4391	2.11	61668	1 6 .		
54	18.2	5110	2.11	61636	1 8 .		
49	20.17	5678	2.11	61605	2 0 .		
45	21.93	6168	1.99	61605	2 2 .		
40	24.29	6833	1.8	61605	2 5 .		
34	28.99	8174	1.48	61587	2 8 .		
30	32.83	9260	1.31	61587	3 2 .		
28	34.93	9822	1.25	61570	3 6 .		
25	39.55	11222	1.11	61570	4 0 .		
21	46.81	13170	0.92	61532	4 5 .		
19	52.76	14816	0.82	61520	5 0 .		

37.0 kW

4 POLE

184	8.03	1843	1.39	34000	K 0 9 3 1 8 . 0 _ M _ _ _ _ 3 7 . A - -	485	225S
152	9.68	2223	1.39	34000	1 0 .		
133	11.06	2541	1.18	34000	1 1 .		
119	12.4	2846	1.1	34000	1 2 .		
111	13.33	3059	1.18	34000	1 4 .		
99	14.94	3428	1.1	34000	1 6 .		
82	17.93	4136	0.84	34000	1 8 .		
68	21.61	4965	0.84	34000	2 2 .		
179	8.26	1902	2.15	35534	K 1 0 3 1 8 . 0 _ M _ _ _ _ 3 7 . A - -	609	225S
148	9.95	2288	2.15	35534	1 0 .		
128	11.54	2665	2.15	35534	1 1 .		
118	12.55	2895	2.13	35534	1 2 .		
106	13.89	3200	2.15	35534	1 4 .		
98	15.11	3482	2.06	35530	1 6 .		
79	18.57	4289	1.64	35530	1 8 .		
74	20.05	4625	1.55	35526	2 0 .		
66	22.35	5148	1.4	35526	2 2 .		
61	24.13	5552	1.29	35526	2 5 .		
50	29.24	6757	1.06	35526	2 8 .		
45	33.1	7646	0.94	35500	3 2 .		
42	35.19	8121	0.89	35500	3 6 .		
173	8.51	1962	2.58	61245	K 1 2 3 1 8 . 0 _ M _ _ _ _ 3 7 . A - -	744	225S
144	10.26	2357	2.58	61326	1 0 .		
125	11.8	2722	2.58	61175	1 1 .		
114	12.96	2993	2.58	61186	1 2 .		
104	14.21	3272	2.58	61350	1 4 .		
94	15.61	3598	2.58	61373	1 6 .		
81	18.2	4187	2.58	61198	1 8 .		
73	20.17	4655	2.53	61151	2 0 .		
67	21.93	5055	2.43	61315	2 2 .		
61	24.29	5599	2.2	60972	2 5 .		
51	28.99	6698	1.81	60972	2 8 .		
45	32.83	7588	1.59	60490	3 2 .		
42	34.93	8032	1.53	59781	3 6 .		
37	39.55	9111	1.35	59781	4 0 .		
32	46.81	10787	1.12	59200	4 5 .		
28	52.76	12157	1	59200	5 0 .		
26	56.39	12930	0.95	58400	5 6 .		
23	63.57	14572	0.84	58400	6 3 .		

NOTE

Other output speeds are available using 2 and 8 pole motors - Consult Application Engineering

SERIES K

SELECTION TABLES

GEARED MOTORS

37.0 kW

6 POLE

N2 R/MIN	i	M2 Nm	Fm	N	Unit Designation	Kg	
Output Speed	Ratio	Output Torque	Service Factor	Overhung Load	Column Entry <input type="text" value="1"/> Through <input type="text" value="20"/> Spaces to be filled when entering order	Weight of base mount unit	Motor Size
115	8.51	2953	1.71	61700	K 1 2 3 1 8 . 0 _ M _ _ _ _ 3 7 . C - -	856	250M
96	10.26	3548	1.71	61700	1 0 .		
83	11.8	4097	1.71	61700	1 1 .		
76	12.96	4505	1.71	61700	1 2 .		
69	14.21	4926	1.71	61700	1 4 .		
63	15.61	5416	1.71	61649	1 6 .		
54	18.2	6303	1.71	61598	1 8 .		
49	20.17	7003	1.71	61547	2 0 .		
45	21.93	7607	1.62	61547	2 2 .		
40	24.29	8427	1.46	61547	2 5 .		
34	28.99	10081	1.2	61535	2 8 .		
30	32.83	11420	1.06	61535	3 2 .		
28	34.93	12114	1.02	61522	3 6 .		
25	39.55	13717	0.9	61522	4 0 .		

45.0 kW

4 POLE

184	8.03	2242	1.15	34000	K 0 9 3 1 8 . 0 _ M _ _ _ _ 4 5 . A - -	520	225M
152	9.68	2704	1.15	34000	1 0 .		
133	11.06	3090	0.97	34000	1 1 .		
119	12.4	3461	0.9	34000	1 2 .		
111	13.33	3720	0.97	34000	1 4 .		
99	14.94	4169	0.9	34000	1 6 .		
179	8.26	2313	1.77	35500	K 1 0 3 1 8 . 0 _ M _ _ _ _ 4 5 . A - -		
148	9.95	2783	1.77	35500	1 0 .		
128	11.54	3241	1.77	35500	1 1 .		
118	12.55	3521	1.75	35500	1 2 .		
106	13.89	3891	1.77	35500	1 4 .		
98	15.11	4235	1.7	35500	1 6 .		
79	18.57	5216	1.35	35500	1 8 .		
74	20.05	5625	1.27	35500	2 0 .		
66	22.35	6261	1.15	35500	2 2 .		
61	24.13	6752	1.06	35500	2 5 .		
50	29.24	8218	0.87	35500	2 8 .		
173	8.51	2386	2.12	60725	K 1 2 3 1 8 . 0 _ M _ _ _ _ 4 5 . A - -		
144	10.26	2867	2.12	60900	1 0 .		
125	11.8	3310	2.12	60575	1 1 .		
114	12.96	3640	2.12	60600	1 2 .		
104	14.21	3980	2.12	60950	1 4 .		
94	15.61	4376	2.12	61000	1 6 .		
81	18.2	5093	2.12	60625	1 8 .		
73	20.17	5661	2.08	60525	2 0 .		
67	21.93	6148	2	60875	2 2 .		
61	24.29	6809	1.81	60583	2 5 .		
51	28.99	8147	1.49	60583	2 8 .		
45	32.83	9228	1.31	60050	3 2 .		
42	34.93	9768	1.26	59167	3 6 .		
37	39.55	11081	1.11	59167	4 0 .		
32	46.81	13119	0.92	58400	4 5 .		
28	52.76	14786	0.82	58400	5 0 .		

45.0 kW

6 POLE

115	8.51	3591	1.41	61700	K 1 2 3 1 8 . 0 _ M _ _ _ _ 4 5 . C - -	981	280S
96	10.26	4315	1.41	61700	1 0 .		
83	11.8	4983	1.41	61700	1 1 .		
76	12.96	5480	1.41	61700	1 2 .		
69	14.21	5991	1.41	61700	1 4 .		
63	15.61	6587	1.41	61627	1 6 .		
54	18.2	7666	1.41	61554	1 8 .		
49	20.17	8518	1.41	61482	2 0 .		
45	21.93	9252	1.33	61482	2 2 .		
40	24.29	10249	1.2	61482	2 5 .		
34	28.99	12261	0.99	61475	2 8 .		
30	32.83	13890	0.87	61475	3 2 .		
28	34.93	14733	0.83	61468	3 6 .		

NOTE

Other output speeds are available using 2 and 8 pole motors - Consult Application Engineering

SERIES K

SELECTION TABLES

GEARED MOTORS

	N2 R/MIN	i	M2 Nm	Fm	N	Unit Designation	Kg				
	Output Speed	Ratio	Output Torque	Service Factor	Overhung Load	Column Entry 1 Through 20 Spaces to be filled when entering order	Weight of base mount unit	Motor Size			
55.0 kW 4 POLE	173	8.51	2916	1.73	60075	K 1 2 3 1 8 . 0 _ M _ _ _ _ 5 5 . A - -	856	250M			
	144	10.26	3504	1.73	60366	1 0 .					
	125	11.8	4046	1.73	59825	1 1 .					
	114	12.96	4449	1.73	59866	1 2 .					
	104	14.21	4864	1.73	60450	1 4 .					
	94	15.61	5349	1.73	60533	1 6 .					
	81	18.2	6225	1.73	59908	1 8 .					
	73	20.17	6919	1.71	59741	2 0 .					
	67	21.93	7514	1.64	60325	2 2 .					
	61	24.29	8323	1.48	60098	2 5 .					
	51	28.99	9957	1.22	60098	2 8 .					
	45	32.83	11279	1.07	59500	3 2 .					
	42	34.93	11939	1.03	58400	3 6 .					
	37	39.55	13544	0.91	58400	4 0 .					
	55.0 kW 6 POLE	115	8.51	4390	1.15	61700			K 1 2 3 1 8 . 0 _ M _ _ _ _ 5 5 . C - -	1071	280M
96		10.26	5274	1.15	61700	1 0 .					
83		11.8	6090	1.15	61700	1 1 .					
76		12.96	6697	1.15	61700	1 2 .					
69		14.21	7322	1.15	61700	1 4 .					
63		15.61	8051	1.15	61600	1 6 .					
54		18.2	9370	1.15	61500	1 8 .					
49		20.17	10411	1.15	61400	2 0 .					
45		21.93	11308	1.09	61400	2 2 .					
40		24.29	12527	0.98	61400	2 5 .					
34		28.99	14986	0.81	61400	2 8 .					
75.0 kW 4 POLE		174	8.51	3950	1.28	58775	K 1 2 3 1 8 . 0 _ M _ _ _ _ 7 5 . A - -	981	280S		
		145	10.26	4746	1.28	59300	1 0 .				
		126	11.8	5480	1.28	58325	1 1 .				
		115	12.96	6027	1.28	58400	1 2 .				
	104	14.21	6589	1.28	59450	1 4 .					
	95	15.61	7245	1.28	59600	1 6 .					
	82	18.2	8431	1.28	58475	1 8 .					
	74	20.17	9372	1.26	58175	2 0 .					
	68	21.93	10178	1.21	59225	2 2 .					
	61	24.29	11273	1.09	59127	2 5 .					
	51	28.99	13487	0.9	59127	2 8 .					
	90.0 kW 4 POLE	174	8.51	4740	1.07	57800	K 1 2 3 1 8 . 0 _ M _ _ _ _ 9 0 . A - -			1071	280M
145		10.26	5696	1.07	58500	1 0 .					
126		11.8	6576	1.07	57200	1 1 .					
115		12.96	7232	1.07	57300	1 2 .					
104		14.21	7907	1.07	58700	1 4 .					
95		15.61	8694	1.07	58900	1 6 .					
82		18.2	10118	1.07	57400	1 8 .					
74		20.17	11246	1.05	57000	2 0 .					
68		21.93	12213	1.01	58400	2 2 .					
61		24.29	13528	0.91	58400	2 5 .					

NOTE
Other output speeds are available using 2 and 8 pole motors - Consult Application Engineering

SERIES K DIMENSIONS TRIPLE REDUCTION

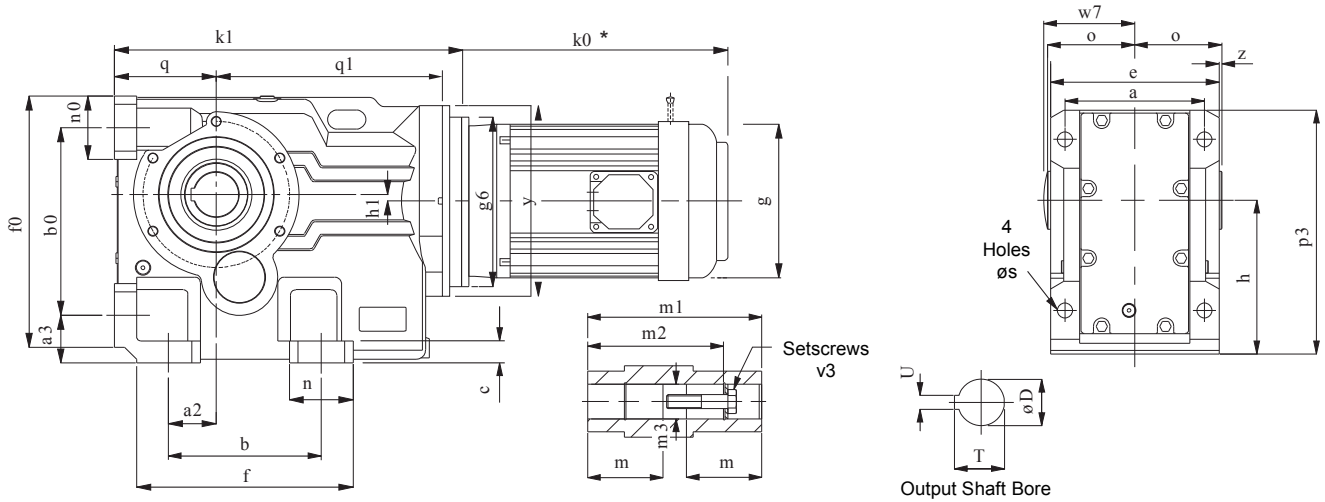

Size	a	a2	a3	b	b0	c	e	f	f0	h	h1	n	n0	o	p3
K0332	100	28	32	110	115	11	120	143	152	100	16	38	38	60	167
K0432	120	35	37	130	130	16	145	168	171	112	13	38	40	75	187
K0532	130	30	45	130	150	15	157	170	192	132	5	40	40	83	217
K0632	140	30	45	120	160	20	170	176	208	140	13	55	48	90	233
K0732	165	40	55	150	200	27	200	210	263	180	25	60	55	105	288
K0832	180	55	70	180	233	30	230	256	309	212	15	76	76	120	341
K0931	240	75	75	240	295	35	290	340	395	265	10	100	100	150	420
K1031	270	95	95	280	360	40	340	390	455	315	41	110	115	175	513
K1231	330	115	110	350	420	45	400	470	540	375	65	120	120	205	590

Size	q	q1	s	w7	y	z	Hollow Output Bore							
							D	m	m1	m2	m3	T	U	v3
K0332	63	159	11	63	140	0	30	52.5	120	105	30.3	33.5	8	M10x50L
K0432	71	179	11	78	140	2.5	35	66	150	132	35.3	38.5	10	M12x55L
K0532	80	219	14	87	180	4.5	40	73	166	142	40.3	43.5	12	M16x70L
K0632	90	229	14	94	180	5	40	80	180	156	40.3	43.5	12	M16x70L
K0732	112	265	18	109	212	5	50	92.5	210	183	50.5	54	14	M16x70L
K0832	132	330	23	124	250	5	60	105	240	210	60.5	64.5	18	M20x80L
K0931	160	355	27	154	300	5	70	132.5	300	270	70.5	75	20	M20x80L
K1031	200	423	34	180	360	5	80	155	350	313	80.5	85.5	22	M20x80L
K1231	225	476	39	210	400	5	100	180	410	373	100.5	106.5	28	M24x110L

MOTOR FRAME SIZE	K0332	K0432	K0532	K0632	K0732	K0832	K0931	K1031	K1231
		K1	K1	K1	K1	K1	K1	K1	K1
63	256	284	311	331	-	-	-	-	-
71	260	288	317	337	-	-	-	-	-
80	273	301	335	355	414	544	573	-	-
90	283	311	345	365	424	544	573	-	-
100	291	319	372	392	436	550	579	670	797
112	291	319	372	392	436	550	579	670	797
132	-	-	372	392	458	550	579	670	797
160	-	-	-	-	466	580	614	705	790
180	-	-	-	-	-	-	614	705	790
200	-	-	-	-	-	-	614	705	790
225	-	-	-	-	-	-	641	732	817
250	-	-	-	-	-	-	-	-	989
280	-	-	-	-	-	-	-	-	989

* Motor Lengths for own brand standard motors can be found on the motor dimension page.

SERIES K

DIMENSIONS

QUINTUPLE REDUCTION

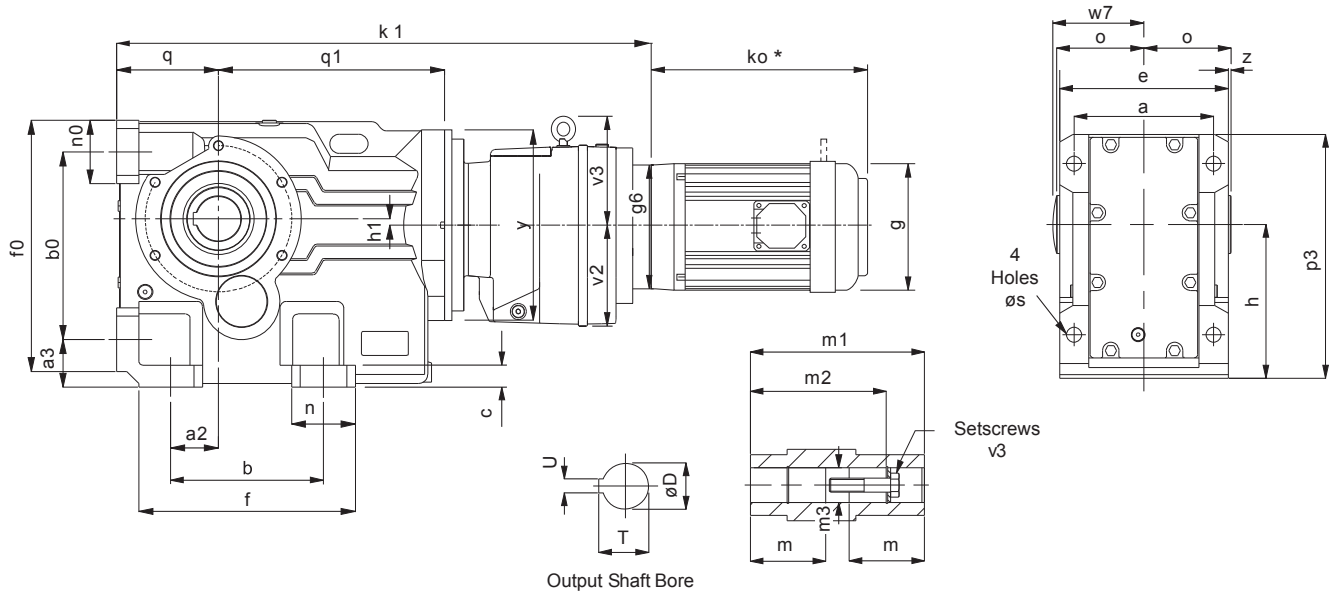

Size	a	a2	a3	b	b0	c	e	f	f0	h	h1	n	n0	o	p3	q
K0352	100	28	32	110	115	11	120	143	152	100	16	38	38	60	167	63
K0452	120	35	37	130	130	16	145	168	171	112	13	38	40	75	187	71
K0552	130	30	45	130	150	15	157	170	192	132	5	40	40	83	217	80
K0652	140	30	45	120	160	20	170	176	208	140	13	55	48	90	233	90
K0752	165	40	55	150	200	27	200	210	263	180	25	60	55	105	288	112
K0852	180	55	70	180	233	30	230	256	309	212	15	76	76	120	341	132
K0951	240	75	75	240	295	35	290	340	395	265	10	100	100	150	420	160
K1051	270	95	95	280	360	40	340	390	455	315	41	110	115	175	513	200
K1251	330	115	110	350	420	45	400	470	540	375	65	120	120	205	590	225

Size	q1	s	v2	v3	w7	y	z	Hollow Output Bore							
								D	m	m1	m2	m3	T	U	v3
K0352	159	11	76	-	63	140	0	30	52.5	120	105	30.3	33.5	8	M10x50L
K0452	179	11	76	-	78	140	2.5	35	66	150	132	35.3	38.5	10	M12x55L
K0552	219	13.5	91	-	87	180	4.5	40	73	166	142	40.3	43.5	12	M16x70L
K0652	229	14	91	-	94	180	5	40	80	180	156	40.3	43.5	12	M16x70L
K0752	265	18	91	-	109	212	5	50	92.5	210	183	50.5	54	14	M16x70L
K0852	330	23	115	-	124	250	5	60	105	240	210	60.5	64.5	18	M20x80L
K0951	355	27	115	-	154	300	5	70	132.5	300	270	70.5	75	20	M20x80L
K1051	423	34	140	155	180	360	5	80	155	350	313	80.5	85.5	22	M20x80L
K1251	476	39	140	155	210	400	5	100	180	410	373	100.5	106.5	28	M24x110L

MOTOR FRAME SIZE	K0352	K0452	K0552	K0652	K0752	K0852	K0951	K1051	K1251
		K1	K1	K1	K1	K1	K1	K1	K1
63	442	470	535	555	614	719	783	-	-
71	446	474	539	559	618	725	789	-	-
80	459	487	552	572	631	743	807	952	1079
90	469	497	562	582	641	753	817	962	1089
100	477	505	570	590	649	780	844	974	1101
112	477	505	570	590	649	780	844	974	1101
132	-	-	-	-	-	780	844	996	1123
160	-	-	-	-	-	-	-	1004	1131

* Motor Lengths (ko) for own brand standard motors can be found on the motor dimension page.

SERIES K

DIMENSIONS

MOTORISED OPTIONS

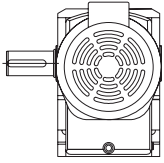

**Single Extended
Outputshaft**

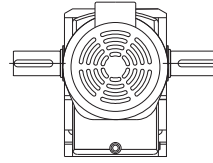

**Double Extended
Outputshaft**

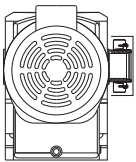

Shrink Disc



Torque Bracket

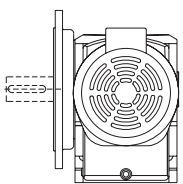

B5 (D) Flange Mounting

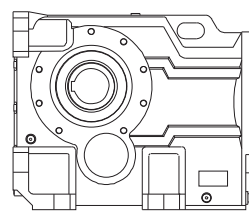

B14 (C) Flange Mounting

SERIES K MOTORISED BACKSTOP MODULE

Motorised backstop modules can be fitted between the gear unit and motor. The backstop device incorporates high quality centrifugal lift off sprags which are wear free above the lift off speed (n min). To ensure correct operation motor speed must exceed lift off speed.

Suitable for ambient temperature -40°C to + 50°C

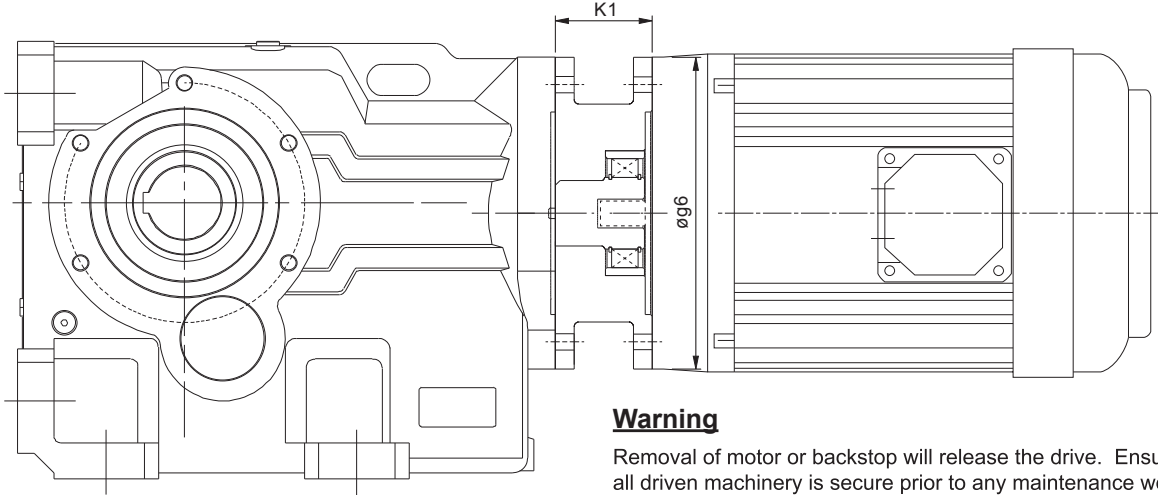

IEC B5 FLANGE

Motor Frame Size	Lift off Speed ('n' min) (rev/min)	Rated Locking Torque ('T max') (at motor) (Nm)	øg6	K1
100	670	170	250	70
112	670	170	250	70
132	620	940	300	95
160	620	940	350	130
180	620	940	350	130
200	550	1260	400	130

NEMA C FLANGE

Motor Frame Size	Lift off Speed ('n' min) (rev/min)	Rated Locking Torque ('T max') (at motor) (Nm)	øg6	K1
182TC / 184TC	670	300	228	95.25
213TC / 215TC	670	300	228	95.25
254TC / 256TC	620	940	228	120.65
284TC / 286TC	620	940	280	136.5
324TC / 326TC	550	1260	330	152.4

When a backstop module is fitted dimension K1 should be added to the overall length of the geared motor assembly.

Rotation of outputshaft must be specified when ordering as viewed from the outputshaft end (as shown in the diagram) see page 18 for column 20 entry

CW	-	Free Rotation	-	Clockwise
		Locked	-	Anticlockwise
AC	-	Free Rotation	-	Anticlockwise
		Locked	-	Clockwise

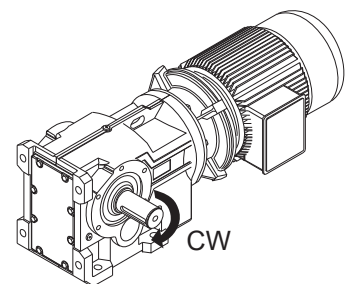

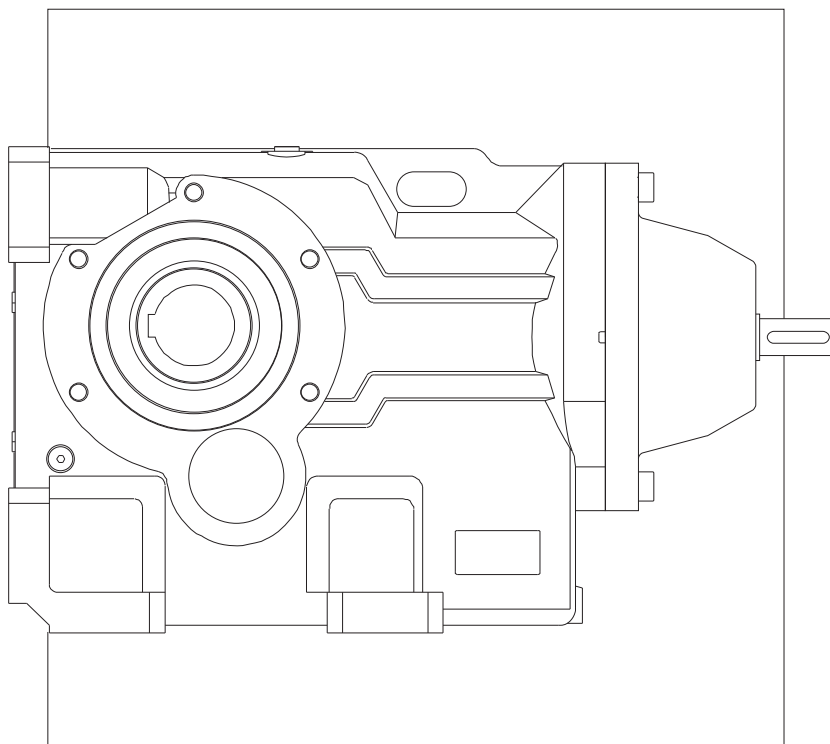

REDUCER
SERIES K

SERIES K

OVERHUNG & AXIAL LOADS (NEWTONS) ON SHAFTS

Maximum permissible overhung loads

When a sprocket, gear etc. is mounted on the shaft a calculation, as below, must be made to determine the overhung load on the shaft, and the results compared to the maximum permissible overhung loads tabulated. Overhung loads can be reduced by increasing the diameter of the sprocket, gear, etc. If the maximum permissible overhung load is exceeded, the sprocket, gear, etc. should be mounted on a separate shaft, flexibly coupled and supported in its own bearings, or the gear unit shaft should be extended to run in an outboard bearing. Alternatively, a larger gear is often a less expensive solution.

Permissible overhung loads vary according to the direction of rotation. The values tabulated are for the most unfavourable direction with the unit transmitting full rated power and the load P applied midway along the shaft extension. Hence they can sometimes be increased for a more favourable direction of rotation, or if the power transmitted is less than the rated capacity of the gear unit, or if the load is applied nearer to the gear unit case. Refer to Application Engineering for further details. In any event, the sprocket, gear etc. should be positioned as close as possible to the gear unit case in order to reduce bearing loads and shaft stresses, and to prolong life.

All units will accept 100% momentary overload on stated capacities.

Overhung load (Newtons)

$$P = \frac{\text{kW} \times 9,500,000 \times K}{N \times R}$$

Where

- P = equivalent overhung load (Newtons)
- kW = power transmitted by the shaft (kilowatts)
- N = speed of shaft (rev/min)
- R = pitch radius of sprocket, etc. (mm)
- K = factor

Note: 1 Newton = 0.101972 kp = 0.227809 lbf.

Overhung member

K (factor)

Chain sprocket*	1.00
Spur or helical pinion	1.25
Vee belt sheave	1.50
Flat belt pulley	2.00

* If multistrand chain drives are equally loaded and the outer strand is further than dimension A output or B input, refer to Application Engineering.

Distance midway along the shaft extension

Size of unit	NO of Reductions	Dimension A (mm)	Dimension B (mm)
K03	3	23.5	20
	5	23.5	20
K04	3	28	20
	5	28	20
K05	3	33	20
	5	33	20
K06	3	38	20
	5	38	20
K07	3	47.5	25
	5	47.5	20
K08	3	50	30
	5	50	20
K09	3	55	40
	5	55	20
K10	3	70	55
	5	70	25
K12	3	90	55
	5	90	25

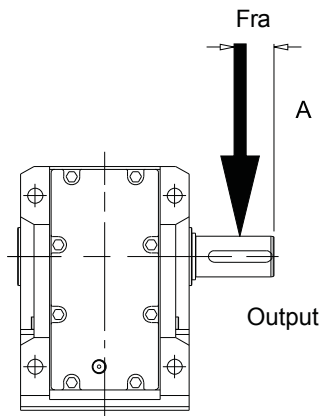
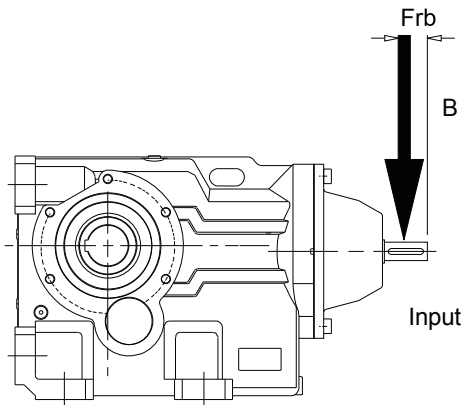

Inputshaft Overhung Loads, F_{rb} (Kn) 1450 rpm

Two, Three and Five Stage Units

	K03	K04	K05	K06	K07	K08	K09	K10	K12
3 Stage	1.50	1.50	1.25	1.05	2.1	3.1	3.5	4.5	12.0
5 Stage	1.50	1.50	1.50	1.50	1.50	1.50	1.50	1.80	1.80

For output overhung load Fra consult ratings tables pages 21 to 87

Axial Thrust Capacities (Newtons)

No check or calculation is required for axial loads (F_A) towards or away from the unit up to 50% of the permissible overhung load. If the axial thrust considerably exceeds these values or if there is a combination of axial thrust loads and overhung loads please contact Application Engineering.

SERIES K

THERMAL POWER RATING

Thermal Ratings kW

Thermal ratings are a measure of the units ability to dissipate heat, if they are exceeded the lubricant may break down resulting in premature gear failure.

Thermal rating are based on an ambient temperature of 20°C, where units are to operate in other ambient temperatures thermal ratings must be adjusted by the following factors

Unit Size	Ambient Temperature °C							
	-20	-10	0	10	20	30	40	50
All Units	1.57	1.43	1.29	1.14	1.00	0.86	0.71	0.5

Thermal Power (kW)

Overall Ratios	Type of Cooling	Input Rev/min	Unit Size								
			K03	K04	K05	K06	K07	K08	K09	K10	K12
8 to 20	Units with no additional cooling	2900	Consult Application Engineering								
		1450	6.4	7.8	11.3	12.1	17.7	20.4	30.8	44	60
		960	6.1	7.4	10.8	11.6	16.9	19.5	29.4	42	57
		725	5.9	7.2	10.5	11.2	16.4	18.9	28.5	41	55
22 to 40	Units with no additional cooling	2900	4.6	5.7	8.2	8.8	12.9	14.8	22.3	32	43
		1450	5.4	6.6	9.6	10.3	15.1	17.7	25.1	35.0	47.9
		960	5.2	6.3	9.2	9.8	14.4	16.9	24.0	33	46
		725	5.0	6.1	8.9	9.5	13.9	16.4	23.2	32	44
45 & over	Units with no additional cooling	2900	3.9	4.8	7.0	7.5	10.9	12.8	18.2	25	35
		1450	4.1	5.8	5.8	9.8	9.8	14.5	19.2	30	42
		960	5.2	6.3	9.2	9.8	14.4	16.9	24.0	33	46
		725	5.0	6.1	8.9	9.5	13.9	16.4	23.2	32	44
8 to 20	Units with Fan cooling	2900	N/A	N/A	N/A	N/A	N/A	N/A	N/A	N/A	N/A
		1450	-	-	-	-	35	41	62	88	119
		960	-	-	-	-	31	36	54	77	104
		725	-	-	-	-	27	31	46	66	89
22 to 40	Units with Fan cooling	2900	N/A	N/A	N/A	N/A	N/A	N/A	N/A	N/A	N/A
		1450	-	-	-	-	30	35	50	70	96
		960	-	-	-	-	26	31	44	61	84
		725	-	-	-	-	23	27	38	53	72
45 & over	Units with Fan cooling	2900	N/A	N/A	N/A	N/A	N/A	N/A	N/A	N/A	N/A
		1450	-	-	-	-	20	29	38	59	85
		960	-	-	-	-	17	25	34	52	74
		725	-	-	-	-	15	22	29	44	63

Note: When checking thermal capacities use actual load required to be transmitted, not rating of prime mover.

SERIES K

TRIPLE REDUCTION RATINGS SIZES K03 - K05

Note: Input Power, Pm may exceed thermal limit, Check thermal power page

Pm - Input Power (kW)
M2 - Output Torque (Nm)
i - Exact Ratio (:1)
N2 - Output Speed (rpm)
fra - Overhung Load (kN)

TRIPLE REDUCTION

Column Entry	Input Speed N1 (rpm)	K0332					K0432					K0532				
		N2 (rpm)	i (:1)	M2 (Nm)	Pm (kW)	fra (kN)	N2 (rpm)	i (:1)	M2 (Nm)	Pm (kW)	fra (kN)	N2 (rpm)	i (:1)	M2 (Nm)	Pm (kW)	fra (kN)
8 . 0	2900	348	8.328	118	4.49	2.88	360	8.054	215	8.48	3.23	358	8.112	323	12.7	2.33
	1450	174		137	2.6	3.46	180		256	5.02	3.67	179		394	7.66	2.65
	960	115		150	1.87	4.04	119		279	3.61	4.33	118		429	5.5	3.20
	725	87		159	1.5	4.49	90		296	2.88	4.84	89		451	4.37	3.66
1 1 .	2900	258	11.25	135	3.78	3.02	257	11.296	255	7.16	3.33	254	11.405	381	10.6	2.35
	1450	129		155	2.17	3.71	128		294	4.1	3.93	127		448	6.19	2.84
	960	85		170	1.57	4.34	85		320	2.95	4.65	84		484	4.42	3.45
	725	64		179	1.25	4.83	64		338	2.35	5.13	64		511	3.52	3.94
1 2 .	2900	227	12.796	141	3.47	3.15	233	12.448	265	6.73	3.44	227	12.783	401	9.93	2.37
	1450	113		163	2	3.97	116		305	3.86	4.20	113		466	5.74	3.04
	960	75		177	1.44	4.65	77		331	2.77	4.97	75		503	4.09	3.69
	725	57		187	1.14	5.17	58		349	2.2	5.42	57		531	3.26	4.23
1 4 .	2900	200	14.497	147	3.21	3.29	205	14.135	277	6.19	3.54	202	14.349	421	9.29	2.38
	1450	100		171	1.85	4.22	103		319	3.55	4.46	101		485	5.32	3.23
	960	66		185	1.33	4.95	68		346	2.54	5.28	67		522	3.78	3.94
	725	50		195	1.06	5.50	51		364	2.02	5.71	51		551	3.01	4.51
1 8 .	2900	156	18.54	159	2.71	3.42	162	17.953	299	5.27	3.64	159	18.222	454	7.88	2.40
	1450	78		184	1.56	4.47	81		344	3.02	4.72	80		519	4.48	3.42
	960	52		200	1.12	5.25	53		372	2.16	5.60	53		561	3.2	4.18
	725	39		210	0.89	5.84	40		382	1.67	6.00	40		592	2.55	4.79
2 0 .	2900	145	19.98	163	2.57	3.61	142	20.396	312	4.83	3.84	140	20.657	471	7.21	2.57
	1450	73		189	1.48	4.72	71		358	2.76	4.99	70		537	4.09	3.65
	960	48		204	1.06	5.55	47		387	1.98	5.80	46		581	2.92	4.46
	725	36		217	0.85	6.00	36		400	1.54	6.00	35		613	2.33	5.18
2 5 .	2900	115	25.225	175	2.19	3.80	116	25.031	332	4.19	4.04	118	24.636	495	6.35	2.73
	1450	57		201	1.25	4.97	58		380	2.39	5.26	59		563	3.6	3.89
	960	38		218	0.9	5.84	38		411	1.71	6.00	39		609	2.57	4.74
	725	29		225	0.7	6.00	29		438	1.37	6.00	29		644	2.05	5.56
2 8 .	2900	101	28.597	182	2.01	3.98	104	27.762	342	3.89	4.24	102	28.367	514	5.73	2.90
	1450	51		208	1.14	5.22	52		391	2.22	5.52	51		584	3.24	4.12
	960	34		225	0.82	6.00	35		423	1.59	6.00	34		632	2.32	5.02
	725	25		225	0.62	6.00	26		430	1.22	6.00	26		659	1.82	5.95
3 2 .	2900	89	32.679	189	1.82	4.17	92	31.539	354	3.55	4.44	88	32.993	532	5.09	3.06
	1450	44		215	1.04	5.47	46		404	2.02	5.79	44		607	2.9	4.35
	960	29		225	0.71	6.00	30		435	1.44	6.00	29		658	2.08	5.30
	725	22		225	0.54	6.00	23		435	1.09	6.00	22		659	1.57	6.33
3 6 .	2900	80	36.352	194	1.69	3.42	81	35.834	375	3.31	3.42	79	36.913	559	4.79	3.13
	1450	40		221	0.96	5.74	40		428	1.89	6.00	39		638	2.72	4.42
	960	26		225	0.64	6.00	27		441	1.29	6.00	26		659	1.86	5.68
	725	20		225	0.49	6.00	20		441	0.97	6.00	20		659	1.4	6.76
4 0 .	2900	72	40.078	198	1.56	3.80	73	39.461	375	3	3.99	74	39.343	555	4.46	3.37
	1450	36		225	0.88	6.00	37		428	1.71	6.00	37		634	2.53	4.83
	960	24		225	0.58	6.00	24		441	1.17	6.00	24		659	1.74	6.06
	725	18		225	0.44	6.00	18		441	0.88	6.00	18		659	1.32	7.02
4 5 .	2900	66	44.107	203	1.45	4.19	64	45.39	388	2.7	4.56	62	46.627	578	3.91	3.61
	1450	33		225	0.8	6.00	32		441	1.53	6.00	31		658	2.22	5.24
	960	22		225	0.53	6.00	21		441	1.01	6.00	21		659	1.47	6.43
	725	16		225	0.4	6.00	16		441	0.77	6.00	16		659	1.11	7.50
5 0 .	2900	56	51.676	211	1.29	4.57	59	49.347	395	2.53	5.12	58	49.784	586	3.72	3.85
	1450	28		225	0.69	6.00	29		441	1.41	6.00	29		658	2.08	5.64
	960	19		225	0.45	6.00	19		441	0.93	6.00	19		659	1.38	6.81
	725	14		225	0.34	6.00	15		441	0.7	6.00	15		659	1.04	7.50
6 3 .	2900	47	61.997	219	1.12	4.95	49	59.241	412	2.2	5.69	47	61.777	615	3.15	4.09
	1450	23		225	0.57	6.00	24		441	1.18	6.00	23		659	1.68	6.05
	960	15		225	0.38	6.00	16		441	0.78	6.00	16		659	1.11	7.16
	725	12		225	0.29	6.00	12		441	0.59	6.00	12		659	0.84	7.50
7 1 .	2900	40	72.268	225	0.98	5.64	41	71.089	429	1.91	6.00	40	72.848	638	2.77	4.37
	1450	20		225	0.49	6.00	20		431	0.96	6.00	20		659	1.43	6.55
	960	13		225	0.32	6.00	14		431	0.64	6.00	13		659	0.94	7.50
	725	10		225	0.25	6.00	10		431	0.48	6.00	10		659	0.71	7.50
8 0 .	2900	36	80.298	225	0.89	6.00	36	80.1	433	1.72	6.00	36	79.767	650	2.58	4.66
	1450	18		225	0.44	6.00	18		433	0.86	6.00	18		659	1.31	7.04
	960	12		225	0.29	6.00	12		434	0.57	6.00	12		659	0.86	7.50
	725	9		225	0.22	6.00	9		434	0.43	6.00	9		659	0.65	7.50
1 0 0	2900	30	96.696	185	0.61	6.00	31	93.116	400	1.36	6.00	30	97.757	658	2.14	4.94
	1450	15		186	0.3	6.00	16		410	0.7	6.00	15		659	1.07	7.50
	960	10		186	0.2	6.00	10		425	0.48	6.00	10		659	0.71	7.50
	725	7		186	0.15	6.00	8		435	0.37	6.00	7		659	0.53	7.50
1 1 2	2900	26	110.833	159	0.46	6.00	27	105.688	409	1.23	6.00	27	108.958	659	1.92	5.22
	1450	13		159	0.23	6.00	14		419	0.63	6.00	13		659	0.96	7.50
	960	9		159	0.15	6.00	9		434	0.43	6.00	9		659	0.63	7.50
	725	7		159	0.11	6.00	7		441	0.33	6.00	7		659	0.48	7.50
1 2 5	2900	23	125.96	157	0.4	6.00	24	120.15	441	1.17	6.00	24	122.196	607	1.58	6.41
	1450	12		157	0.2	6.00	12		441	0.58	6.00	12		608	0.79	7.50
	960	8		157	0.13	6.00	8		441	0.39	6.00	8		608	0.52	7.50
	725	6		157	0.1	6.00	6		441	0.29	6.00	6		608	0.4	7.50

SERIES K

TRIPLE REDUCTION RATINGS SIZES K06 - K08

Note: Input Power, Pm may exceed thermal limit, Check thermal power page

Pm - Input Power (kW)
 M2 - Output Torque (Nm)
 i - Exact Ratio (:1)
 N2 - Output Speed (rpm)
 fra - Overhung Load (kN)

TRIPLE REDUCTION

Column Entry	Input Speed N1 (rpm)	K0632					K0732					K0832				
		N2 (rpm)	i (:1)	M2 (Nm)	Pm (kW)	fra (kN)	N2 (rpm)	i (:1)	M2 (Nm)	Pm (kW)	fra (kN)	N2 (rpm)	i (:1)	M2 (Nm)	Pm (kW)	fra (kN)
8 . 0	2900	364	7.961	459	18.3	3.55	337	8.595	705	26.1	4.10	357	8.128	1050	41.3	6.00
	1450	182		559	11.1	3.92	169		709	13.1	6.00	178		1060	20.7	6.00
	960	121		608	7.95	4.71	112		711	8.65	7.40	118		1060	13.7	6.00
	725	91		640	6.31	5.27	84		712	6.53	8.50	89		1060	10.3	6.00
1 1 .	2900	259	11.192	545	15.4	3.56	244	11.906	988	25.8	4.12	252	11.522	1500	41.3	6.00
	1450	130		641	9.01	4.20	122		985	13.1	6.02	126		1500	20.7	6.00
	960	86		693	6.43	5.05	81		987	8.65	7.42	83		1510	13.7	6.00
	725	65		731	5.12	5.73	61		988	6.53	8.53	63		1510	10.3	6.00
1 2 .	2900	231	12.545	574	14.5	3.57	217	13.374	1020	24.2	4.13	227	12.8	1660	41.3	6.00
	1450	116		669	8.38	4.47	108		1110	13.1	6.04	113		1670	20.7	6.00
	960	77		721	5.98	5.40	72		1110	8.65	7.44	75		1680	13.7	6.00
	725	58		761	4.76	6.20	54		1110	6.53	8.55	57		1680	10.3	6.00
1 4 .	2900	206	14.081	605	13.6	3.57	197	14.705	1070	23.1	4.15	204	14.238	1840	41.1	6.00
	1450	103		696	7.77	4.75	99		1220	13.1	6.06	102		1860	20.7	6.00
	960	68		750	5.54	5.74	65		1220	8.65	7.46	67		1860	13.7	6.41
	725	51		791	4.41	6.66	49		1220	6.53	8.58	51		1870	10.3	6.81
1 8 .	2900	162	17.882	655	11.6	3.58	151	19.208	1190	19.6	4.16	158	18.41	2010	34.7	6.00
	1450	81		748	6.58	5.02	75		1350	11.1	6.08	79		2300	19.7	6.00
	960	54		809	4.7	6.08	50		1460	7.93	7.48	52		2410	13.7	6.81
	725	41		827	3.63	7.12	38		1540	6.32	8.60	39		2410	10.3	8.46
2 0 .	2900	143	20.272	681	10.6	3.82	133	21.838	1240	17.9	4.43	140	20.668	2060	31.6	6.00
	1450	72		777	6.02	5.44	66		1400	10.1	6.46	70		2350	17.9	6.40
	960	47		826	4.24	6.56	44		1520	7.25	7.99	46		2590	13.1	7.43
	725	36		827	3.2	7.56	33		1600	5.77	9.30	35		2700	10.3	9.20
2 5 .	2900	120	24.177	718	9.36	4.05	109	26.518	1320	15.7	4.70	114	25.345	2140	26.7	6.00
	1450	60		817	5.31	5.85	55		1490	8.85	6.83	57		2440	15.2	6.79
	960	40		827	3.55	7.04	36		1610	6.33	8.50	38		2700	11.1	8.06
	725	30		827	2.68	8.00	27		1670	4.96	10.0	29		2700	8.39	9.93
2 8 .	2900	104	27.838	747	8.46	4.29	99	29.17	1350	14.7	4.96	102	28.56	2190	24.3	6.00
	1450	52		826	4.67	6.27	50		1530	8.26	7.21	51		2530	14	6.81
	960	34		827	3.09	7.52	33		1650	5.91	9.00	34		2700	9.87	8.68
	725	26		827	2.33	8.00	25		1670	4.51	10.7	25		2700	7.45	10.7
3 2 .	2900	90	32.378	774	7.54	4.52	87	33.519	1390	13.2	5.23	87	33.244	2250	21.5	6.00
	1450	45		826	4.02	6.68	43		1580	7.44	7.58	44		2640	12.6	7.58
	960	30		827	2.66	8.00	29		1670	5.2	9.51	29		2700	8.48	9.30
	725	22		827	2.01	8.00	22		1670	3.92	11.4	22		2700	6.4	11.4
3 6 .	2900	80	36.225	805	7.02	4.68	76	38.009	1450	12.1	5.49	79	36.877	2300	19.8	6.30
	1450	40		827	3.59	7.15	38		1660	6.9	7.96	39		2700	11.6	7.96
	960	27		827	2.38	8.00	25		1670	4.59	10.4	26		2700	7.66	10.6
	725	20		827	1.8	8.00	19		1670	3.47	12.1	20		2700	5.78	12.5
4 0 .	2900	75	38.61	811	6.63	5.12	69	41.923	1470	11.1	5.88	72	40.357	2340	18.3	6.43
	1450	38		827	3.37	7.36	35		1670	6.29	8.69	36		2700	10.6	8.58
	960	25		827	2.23	8.00	23		1670	4.16	11.4	24		2700	6.99	12.0
	725	19		827	1.68	8.00	17		1670	3.14	12.8	18		2700	5.28	13.6
4 5 .	2900	63	45.758	826	5.7	5.55	60	48.011	1520	10	6.27	64	45.657	2390	16.6	6.56
	1450	32		827	2.85	7.58	30		1670	5.49	9.43	32		2700	9.35	9.20
	960	21		827	1.88	8.00	20		1670	3.64	12.3	21		2700	6.18	13.3
	725	16		827	1.42	8.00	15		1670	2.74	13.5	16		2700	4.67	14.8
5 0 .	2900	59	48.855	826	5.34	5.99	53	54.284	1560	9.1	6.66	56	51.537	2450	15.1	6.68
	1450	30		827	2.67	7.79	27		1670	4.86	10.2	28		2700	8.29	9.90
	960	20		827	1.76	8.00	18		1670	3.22	13.2	19		2700	5.48	14.6
	725	15		827	1.33	8.00	13		1670	2.43	14.2	14		2700	4.14	15.7
6 3 .	2900	48	60.625	826	4.31	6.42	46	62.936	1620	8.13	7.05	46	62.475	2590	13.2	6.81
	1450	24		827	2.15	8.00	23		1670	4.2	10.9	23		2700	6.84	10.6
	960	16		827	1.42	8.00	15		1670	2.78	13.9	15		2700	4.53	15.7
	725	12		827	1.07	8.00	12		1670	2.1	15.0	12		2700	3.42	15.7
7 1 .	2900	41	71.489	827	3.66	6.95	39	75.066	1670	7.06	7.91	40	72.857	2700	11.8	7.73
	1450	20		827	1.83	8.00	19		1670	3.52	11.9	20		2700	5.87	11.7
	960	13		827	1.21	8.00	13		1670	2.33	14.6	13		2700	3.89	15.7
	725	10		827	0.91	8.00	10		1670	1.76	15.0	10		2700	2.93	15.7
8 0 .	2900	37	78.279	827	3.34	7.48	35	82.205	1670	6.45	8.78	36	80.031	2700	10.7	8.66
	1450	19		827	1.67	8.00	18		1670	3.22	12.8	18		2700	5.35	12.8
	960	12		827	1.1	8.00	12		1670	2.13	15.0	12		2700	3.54	15.7
	725	9		827	0.83	8.00	9		1670	1.61	15.0	9		2700	2.67	15.7
1 0 0	2900	30	95.934	827	2.73	8.00	29	98.646	1670	5.38	9.64	30	98.077	2700	8.74	9.20
	1450	15		827	1.36	8.00	15		1670	2.69	13.5	15		2700	4.37	15.7
	960	10		827	0.9	8.00	10		1670	1.78	15.0	10		2700	2.89	15.7
	725	8		827	0.68	8.00	7		1670	1.34	15.0	7		2700	2.18	15.7
1 1 2	2900	27	106.926	827	2.45	8.00	26	113.496	1620	4.56	10.5	27	107.1	2700	8.01	10.5
	1450	14		827	1.23	8.00	13		1630	2.28	14.1	14		2700	4	15.7
	960	9		827	0.81	8.00	8		1630	1.51	15.0	9		2700	2.65	15.7
	725	7		827	0.61	8.00	6		1630	1.14	15.0	7		2700	2	15.7
1 2 5	2900	24	119.917	595	1.58	8.00	23	126.107	1380	3.49	11.0	24	123.327	2700	6.98	10.8
	1450	12		596	0.79	8.00	11		1380	1.75	15.0	12		2700	3.49	15.7
	960	8		596	0.52	8.00	8		1380	1.16	15.0	8		2700	2.31	15.7
	725	6		596	0.4	8.00	6		1380	0.87	15.0	6		2700	1.74	15.7

SERIES K

TRIPLE REDUCTION RATINGS SIZES K09 - K12

Note: Input Power, Pm may exceed thermal limit, Check thermal power page

Pm - Input Power (kW)
M2 - Output Torque (Nm)
i - Exact Ratio (:1)
N2 - Output Speed (rpm)
fra - Overhung Load (kN)

TRIPLE REDUCTION

Column Entry			K0931				K1031					K1231						
6	7	8	Input Speed N1 (rpm)	N2 (rpm)	i (:1)	M2 (Nm)	Pm (kW)	fra (kN)	N2 (rpm)	i (:1)	M2 (Nm)	Pm (kW)	fra (kN)	N2 (rpm)	i (:1)	M2 (Nm)	Pm (kW)	fra (kN)
8	.	0	2900	361	8.035	2090	82.8	22.9	351	8.263	4070	156	22.9	341	8.513	5240	195	56.5
			1450	180		2570	50.7	25.2	175		4090	78.2	25.2	170		5260	97.4	56.5
			960	119		2910	37.8	27.7	116		4100	51.8	34.0	113		5260	64.5	56.5
			725	90		3050	30	30.0	88		4100	39.1	34.0	85		5260	48.7	56.6
1	0	.	2900	300	9.681	2510	82.8	22.9	292	9.946	4890	156	22.9	283	10.256	6300	195	56.5
			1450	150		3100	50.7	25.2	146		4920	78.2	25.2	141		6320	97.4	56.5
			960	99		3500	37.8	27.7	97		4920	51.8	34.0	94		6320	64.5	56.5
			725	75		3670	29.9	30.0	73		4930	39.1	34.0	71		6330	48.7	56.6
1	1	.	2900	262	11.061	2430	69.8	23.5	251	11.542	4820	132	25.7	246	11.799	7290	195	56.5
			1450	131		2990	42.8	26.5	126		5730	78.2	29.6	123		7300	97.4	56.5
			960	87		3240	30.6	29.0	83		5730	51.8	35.8	81		7300	64.5	56.5
			725	66		3370	24	31.0	63		5740	39.1	36.3	61		7310	48.7	57.8
1	2	.	2900	234	12.398	2560	65.5	24.1	231	12.553	5010	126	28.5	224	12.96	8010	195	56.5
			1450	117		3130	40	27.7	116		6170	77.5	34.0	112		8020	97.4	56.5
			960	77		3350	28.2	30.3	76		6240	51.8	37.6	74		8020	64.5	56.5
			725	58		3510	22.3	32.0	58		6240	39.1	38.6	56		8030	48.7	59.0
1	4	.	2900	218	13.328	2920	69.8	24.6	209	13.893	5790	132	31.2	204	14.214	8760	195	56.5
			1450	109		3600	42.8	29.0	104		6880	78.2	35.8	102		8770	97.4	56.5
			960	72		3900	28.8	31.7	69		6890	51.8	40.1	68		8780	64.5	57.7
			725	54		3670	21.7	34.0	52		6890	39.1	43.1	51		8780	48.7	60.1
1	6	.	2900	194	14.938	3070	65.5	24.6	192	15.11	6020	126	31.2	186	15.613	9630	195	56.5
			1450	97		3770	39.9	29.5	96		7190	75.1	36.4	93		9640	97.4	56.5
			960	64		4030	28.22	32.5	64		7190	49.7	41.5	61		9640	64.5	57.8
			725	49		4030	21.30	34.0	48		7190	37.5	43.1	46		9650	48.7	61.3
1	8	.	2900	162	17.933	2980	52.8	25.2	156	18.571	5920	101	34.0	159	18.203	9410	163	56.5
			1450	81		3480	30.6	30.3	78		7040	59.7	37.6	80		11300	97.4	56.5
			960	54		3720	21.6	33.1	52		7190	40.3	42.5	53		11300	64.5	58.9
			725	40		3720	16.3	34.0	39		7190	30.4	43.1	40		11300	48.7	61.3
2	0	.	2900	145	20.035	3110	49.3	26.5	145	20.05	6100	96.1	34.9	144	20.166	9800	153	56.5
			1450	72		3560	28.1	31.2	72		7160	56.3	39.0	72		11800	92.2	57.7
			960	48		3770	19.6	34.0	48		7190	37.4	43.1	48		12100	62.4	61.3
			725	36		3780	14.8	34.0	36		7190	28.2	43.1	36		12100	47.1	61.3
2	2	.	2900	134	21.608	3590	52.8	27.0	130	22.354	7110	101	35.4	132	21.93	11300	163	56.6
			1450	67		4150	30.4	32.5	65		7190	50.8	41.5	66		12300	88.5	59.8
			960	44		4210	20.4	34.0	43		7190	33.6	43.1	44		12300	58.6	61.3
			725	34		4210	15.4	34.0	32		7190	25.4	43.1	33		12300	44.2	61.3
2	5	.	2900	120	24.14	3710	48.3	27.8	120	24.134	7190	94.3	35.8	119	24.294	11800	153	56.5
			1450	60		4210	27.7	32.2	60		7190	47.1	40.4	60		12300	79.9	58.9
			960	40		4210	18.3	34.0	40		7190	31.1	43.1	40		12300	52.9	61.3
			725	30		4210	13.8	34.0	30		7190	23.5	43.1	30		12300	39.9	61.3
2	8	.	2900	104	27.777	3460	39.4	29.0	99	29.239	7050	76.1	36.7	100	28.995	11400	124	56.5
			1450	52		3760	21.4	34.0	50		7190	38.7	43.1	50		12100	65.7	61.3
			960	35		3780	14.2	34.0	33		7190	25.6	43.1	33		12100	43.5	61.3
			725	26		3780	10.7	34.0	25		7190	19.3	43.1	25		12100	32.8	61.3
3	2	.	2900	92	31.672	3550	35.6	30.3	88	33.099	7190	68.6	37.6	88	32.831	11700	112	56.5
			1450	46		3780	18.8	34.0	44		7190	34.2	43.1	44		12100	58	61.3
			960	30		3780	12.4	34.0	29		7190	22.6	43.1	29		12100	38.4	61.3
			725	23		3780	9.40	34.0	22		7190	17.1	43.1	22		12100	29	61.3
3	6	.	2900	87	33.469	3950	37.5	31.8	82	35.195	7190	64.7	39.5	83	34.931	12300	111	59.3
			1450	43		4210	19.9	34.0	41		7190	32.2	43.1	42		12300	55.7	61.3
			960	29		4210	13.2	34.0	27		7190	21.3	43.1	27		12300	36.8	61.3
			725	22		4210	9.95	34.0	21		7190	16.1	43.1	21		12300	27.8	61.3

SERIES K

TRIPLE REDUCTION RATINGS SIZES K09 - K12

Note: Input Power, Pm may exceed thermal limit, Check thermal power page

Pm - Input Power (kW)
M2 - Output Torque (Nm)
i - Exact Ratio (:1)
N2 - Output Speed (rpm)
fra - Overhung Load (kN)

TRIPLE REDUCTION

Column Entry	Input Speed N1 (rpm)	K0931					K1031					K1231				
		N2 (rpm)	i (:1)	M2 (Nm)	Pm (kW)	fra (kN)	N2 (rpm)	i (:1)	M2 (Nm)	Pm (kW)	fra (kN)	N2 (rpm)	i (:1)	M2 (Nm)	Pm (kW)	fra (kN)
4 0 .	2900	76	38.162	4050	34.6	32.4	73	39.841	7190	57.1	40.4	73	39.553	12300	98.4	59.8
	1450	38		4210	17.4	34.0	36		7190	28.5	43.1	37		12300	49.1	61.3
	960	25		4210	11.6	34.0	24		7190	18.8	43.1	24		12300	32.5	61.3
	725	19		4210	8.7	34.0	18		7190	14.2	43.1	18		12300	24.5	61.3
4 5 .	2900	65	44.892	3780	26.7	32.9	64	45.366	7190	50.1	41.3	62	46.81	12100	81.8	60.3
	1450	32		3780	13.3	34.0	32		7190	25	43.1	31		12100	40.8	61.3
	960	21		3780	8.79	34.0	21		7190	16.5	43.1	21		12100	27	61.3
	725	16		3780	6.64	34.0	16		7190	12.5	43.1	15		12100	20.4	61.3
5 0 .	2900	58	49.875	3770	24.0	33.5	58	50.412	7190	45.1	42.2	55	52.764	12100	72.5	60.8
	1450	29		3780	11.9	34.0	29		7190	22.5	43.1	27		12100	36.2	61.3
	960	19		3780	7.92	34.0	19		7190	14.9	43.1	18		12100	24	61.3
	725	15		3780	5.98	34.0	14		7190	11.2	43.1	14		12100	18.1	61.3
5 6 .	2900	54	54.091	4210	24.8	34.0	53	54.607	7190	41.7	43.1	51	56.394	12300	69.3	61.3
	1450	27		4210	12.3	34.0	27		7190	20.8	43.1	26		12300	34.6	61.3
	960	18		4210	8.18	34.0	18		7190	13.8	43.1	17		12300	22.9	61.3
	725	13		4210	6.16	34.0	13		7190	10.4	43.1	13		12300	17.3	61.3
6 3 .	2900	48	60.095	4210	22.3	34.0	48	60.681	7190	37.6	43.1	46	63.567	12300	61.4	61.3
	1450	24		4210	11.13	34.0	24		7190	18.7	43.1	23		12300	30.7	61.3
	960	16		4210	7.36	34.0	16		7190	12.4	43.1	15		12300	20.3	61.3
	725	12		4210	5.55	34.0	12		7190	9.36	43.1	11		12300	15.3	61.3
7 1 .	2900	41	70.45	3780	17.0	34.0	40	71.889	7190	31.6	43.1	39	74.616	12100	51.5	61.3
	1450	21		3780	8.50	34.0	20		7190	15.8	43.1	19		12100	25.7	61.3
	960	14		3780	5.62	34.0	13		7190	10.4	43.1	13		12100	17	61.3
	725	10		3780	4.24	34.0	10		7190	7.89	43.1	10		12100	12.9	61.3
8 0 .	2900	37	77.775	3780	15.4	34.0	35	82.832	7190	27.5	43.1	35	83.103	12100	46.3	61.3
	1450	19		3780	7.70	34.0	18		7190	13.7	43.1	17		12100	23.1	61.3
	960	12		3780	5.09	34.0	12		7190	9.08	43.1	12		12100	15.3	61.3
	725	9		3780	3.87	34.0	9		7190	6.85	43.1	9		12100	11.6	61.3
9 0 .	2900	34	84.887	4210	15.9	34.0	34	86.533	7190	26.3	43.1	32	89.893	12300	43.6	61.3
	1450	17		4210	7.89	34.0	17		7190	13.1	43.1	16		12300	21.8	61.3
	960	11		4210	5.22	34.0	11		7190	8.7	43.1	11		12300	14.4	61.3
	725	9		4210	3.94	34.0	8		7190	6.57	43.1	8		12300	10.9	61.3
1 0 0	2900	31	93.713	4210	14.4	34.0	29	99.705	7190	22.9	43.1	29	100.119	12300	39.2	61.3
	1450	15		4210	7.14	34.0	15		7190	11.4	43.1	14		12300	19.6	61.3
	960	10		4210	4.72	34.0	10		7190	7.56	43.1	10		12300	13	61.3
	725	8		4210	3.56	34.0	7		7190	5.71	43.1	7		12300	9.79	61.3
1 1 2	2900	27	106.992	3780	11.2	34.0	26	112.026	7190	20.4	43.1	25	113.789	12100	33.7	61.3
	1450	14		3780	5.60	34.0	13		7190	10.2	43.1	13		12100	16.9	61.3
	960	9		3780	3.71	34.0	9		7190	6.73	43.1	8		12100	11.2	61.3
	725	7		3780	2.80	34.0	6		7190	5.08	43.1	6		12100	8.43	61.3
1 2 5	2900	24	120.31	3780	10.0	34.0	24	120.359	7190	19	43.1	24	121.064	12100	31.7	61.3
	1450	12		3780	4.99	34.0	12		7190	9.48	43.1	12		12100	15.8	61.3
	960	8		3780	3.30	34.0	8		7190	6.27	43.1	8		12100	10.5	61.3
	725	6		3780	2.50	34.0	6		7190	4.74	43.1	6		12100	7.92	61.3
1 4 0	2900	22	128.917	4210	10.4	34.0	22	134.846	7190	17	43.1	21	137.087	12300	28.6	61.3
	1450	11		4210	5.21	34.0	11		7190	8.47	43.1	11		12300	14.3	61.3
	960	7		4210	3.44	34.0	7		7190	5.6	43.1	7		12300	9.44	61.3
	725	6		4210	2.59	34.0	5		7190	4.23	43.1	5		12300	7.13	61.3
1 6 0	2900	20	144.964	4210	9.30	34.0	20	144.876	7190	15.8	43.1	20	145.852	12300	26.8	61.3
	1450	10		4210	4.64	34.0	10		7190	7.89	43.1	10		12300	13.4	61.3
	960	7		4210	3.07	34.0	7		7190	5.22	43.1	7		12300	8.87	61.3
	725	5		4210	2.32	34.0	5		7190	3.94	43.1	5		12300	6.7	61.3

SERIES K

QUINTUPLE REDUCTION RATINGS

SIZES K03 - K05

Note: Input Power, Pm may exceed thermal limit, Check thermal power page

- Pm - Input Power (kW)
- M2 - Output Torque (Nm)
- i - Exact Ratio (:1)
- N2 - Output Speed (rpm)
- fra - Overhung Load (kN)

QUINTUPLE REDUCTION

Column Entry	Input Speed N1 (rpm)	K0352					K0452					K0552				
		N2 (rpm)	i (:1)	M2 (Nm)	Pm (kW)	fra (kN)	N2 (rpm)	i (:1)	M2 (Nm)	Pm (kW)	fra (kN)	N2 (rpm)	i (:1)	M2 (Nm)	Pm (kW)	fra (kN)
1 2 5	2900	22.69	128	225	0.56	6.00	21.58	134	440	1.05	6.00	24.49	118	660	1.78	7.50
	1450	11.35		225	0.28	6.00	10.79		440	0.52	6.00	12.25		660	0.89	7.50
	960	7.51		225	0.19	6.00	7.14		440	0.35	6.00	8.11		660	0.59	7.50
	725	5.63		225	0.14	6.00	5.36		440	0.26	6.00	6.08		660	0.44	7.50
1 4 0	2900	19.95	145	225	0.49	6.00	19.60	148	440	0.95	6.00	20.31	143	660	1.48	7.50
	1450	9.98		225	0.25	6.00	9.80		440	0.48	6.00	10.16		660	0.74	7.50
	960	6.60		225	0.16	6.00	6.49		440	0.31	6.00	6.72		660	0.49	7.50
	725	4.95		225	0.12	6.00	4.87		440	0.24	6.00	5.04		660	0.37	7.50
1 6 0	2900	17.61	165	225	0.44	6.00	17.04	170	440	0.83	6.00	18.43	157	660	1.34	7.50
	1450	8.81		225	0.22	6.00	8.52		440	0.41	6.00	9.22		660	0.67	7.50
	960	5.83		225	0.14	6.00	5.64		440	0.27	6.00	6.10		660	0.44	7.50
	725	4.37		225	0.11	6.00	4.23		440	0.21	6.00	4.58		660	0.33	7.50
2 0 0	2900	13.77	211	225	0.34	6.00	14.51	200	440	0.70	6.00	13.96	208	660	1.02	7.50
	1450	6.89		225	0.17	6.00	7.25		440	0.35	6.00	6.98		660	0.51	7.50
	960	4.56		225	0.11	6.00	4.80		440	0.23	6.00	4.62		660	0.34	7.50
	725	3.42		225	0.08	6.00	3.60		440	0.17	6.00	3.46		660	0.25	7.50
2 5 0	2900	12.78	227	225	0.32	6.00	11.26	258	440	0.55	6.00	10.99	264	660	0.80	7.50
	1450	6.39		225	0.16	6.00	5.63		440	0.27	6.00	5.49		660	0.40	7.50
	960	4.23		225	0.10	6.00	3.73		440	0.18	6.00	3.64		660	0.26	7.50
	725	3.17		225	0.079	6.00	2.80		440	0.14	6.00	2.73		660	0.20	7.50
2 8 0	2900	10.12	287	225	0.25	6.00	10.20	284	440	0.49	6.00	9.67	300	660	0.70	7.50
	1450	5.06		225	0.13	6.00	5.10		440	0.25	6.00	4.84		660	0.35	7.50
	960	3.35		225	0.083	6.00	3.38		440	0.16	6.00	3.20		660	0.23	7.50
	725	2.51		225	0.062	6.00	2.53		440	0.12	6.00	2.40		660	0.17	7.50
3 2 0	2900	8.93	325	225	0.22	6.00	9.00	322	440	0.44	6.00	9.17	316	660	0.67	7.50
	1450	4.46		225	0.11	6.00	4.50		440	0.22	6.00	4.58		660	0.33	7.50
	960	2.96		225	0.073	6.00	2.98		440	0.14	6.00	3.03		660	0.22	7.50
	725	2.22		225	0.055	6.00	2.23		440	0.11	6.00	2.28		660	0.17	7.50
3 6 0	2900	7.81	371	225	0.19	6.00	8.17	355	440	0.40	6.00	8.26	351	660	0.60	7.50
	1450	3.91		225	0.097	6.00	4.08		440	0.20	6.00	4.13		660	0.30	7.50
	960	2.59		225	0.064	6.00	2.70		440	0.13	6.00	2.74		660	0.20	7.50
	725	1.94		225	0.048	6.00	2.03		440	0.098	6.00	2.05		660	0.15	7.50
4 0 0	2900	7.02	413	225	0.17	6.00	7.12	407	440	0.35	6.00	7.27	399	660	0.53	7.50
	1450	3.51		225	0.087	6.00	3.56		440	0.17	6.00	3.64		660	0.26	7.50
	960	2.32		225	0.058	6.00	2.36		440	0.11	6.00	2.41		660	0.18	7.50
	725	1.74		225	0.043	6.00	1.77		440	0.086	6.00	1.81		660	0.13	7.50
4 5 0	2900	6.37	455	225	0.16	6.00	6.47	448	440	0.31	6.00	6.40	453	660	0.47	7.50
	1450	3.19		225	0.079	6.00	3.23		440	0.16	6.00	3.20		660	0.23	7.50
	960	2.11		225	0.052	6.00	2.14		440	0.104	6.00	2.12		660	0.15	7.50
	725	1.58		225	0.039	6.00	1.61		440	0.078	6.00	1.59		660	0.12	7.50
5 0 0	2900	5.62	516	225	0.14	6.00	5.71	508	440	0.28	6.00	5.81	499	660	0.42	7.50
	1450	2.81		225	0.070	6.00	2.85		440	0.14	6.00	2.91		660	0.21	7.50
	960	1.86		225	0.046	6.00	1.89		440	0.092	6.00	1.92		660	0.14	7.50
	725	1.40		225	0.035	6.00	1.42		440	0.069	6.00	1.44		660	0.11	7.50
5 6 0	2900	5.11	568	225	0.13	6.00	4.99	581	440	0.24	6.00	5.05	574	660	0.37	7.50
	1450	2.55		225	0.063	6.00	2.50		440	0.12	6.00	2.53		660	0.18	7.50
	960	1.69		225	0.042	6.00	1.65		440	0.080	6.00	1.67		660	0.12	7.50
	725	1.27		225	0.031	6.00	1.24		440	0.060	6.00	1.25		660	0.09	7.50
6 3 0	2900	4.47	649	225	0.11	6.00	4.49	646	440	0.22	6.00	4.65	624	660	0.34	7.50
	1450	2.23		225	0.055	6.00	2.24		440	0.11	6.00	2.32		660	0.17	7.50
	960	1.48		225	0.037	6.00	1.49		440	0.072	6.00	1.54		660	0.11	7.50
	725	1.11		225	0.028	6.00	1.11		440	0.054	6.00	1.15		660	0.084	7.50
7 0 0	2900	4.12	704	225	0.10	6.00	4.07	712	440	0.20	6.00	4.00	725	660	0.29	7.50
	1450	2.06		225	0.051	6.00	2.04		440	0.10	6.00	2.00		660	0.15	7.50
	960	1.36		225	0.034	6.00	1.35		440	0.065	6.00	1.32		660	0.096	7.50
	725	1.02		225	0.025	6.00	1.01		440	0.049	6.00	0.99		660	0.072	7.50
8 0 0	2900	3.63	798	225	0.090	6.00	3.59	808	440	0.17	6.00	3.57	812	660	0.26	7.50
	1450	1.82		225	0.045	6.00	1.80		440	0.087	6.00	1.79		660	0.13	7.50
	960	1.20		225	0.030	6.00	1.19		440	0.058	6.00	1.18		660	0.086	7.50
	725	0.902		225	0.022	6.00	0.891		440	0.043	6.00	0.887		660	0.065	7.50
9 0 0	2900	3.18	912	225	0.079	6.00	3.26	891	440	0.16	6.00	3.23	899	660	0.23	7.50
	1450	1.59		225	0.039	6.00	1.63		440	0.079	6.00	1.61		660	0.12	7.50
	960	1.05		225	0.026	6.00	1.08		440	0.052	6.00	1.07		660	0.078	7.50
	725	0.789		225	0.020	6.00	0.808		440	0.039	6.00	0.801		660	0.058	7.50
1 0 c	2900	2.86	1015	225	0.071	6.00	2.90	1000	440	0.14	6.00	2.77	1045	660	0.20	7.50
	1450	1.43		225	0.035	6.00	1.45		440	0.070	6.00	1.39		660	0.10	7.50
	960	0.946		225	0.023	6.00	0.960		440	0.047	6.00	0.919		660	0.067	7.50
	725	0.709		225	0.018	6.00	0.720		440	0.035	6.00	0.689		660	0.050	7.50

SERIES K

QUINTUPLE REDUCTION RATINGS SIZES K03 - K05

Note: Input Power, Pm may exceed thermal limit, Check thermal power page

- Pm - Input Power (kW)
- M2 - Output Torque (Nm)
- i - Exact Ratio (:1)
- N2 - Output Speed (rpm)
- fra - Overhung Load (kN)

QUINTUPLE REDUCTION

Column Entry 6 7 8	Input Speed N1 (rpm)	K0352					K0452					K0552				
		N2 (rpm)	i (:1)	M2 (Nm)	Pm (kW)	fra (kN)	N2 (rpm)	i (:1)	M2 (Nm)	Pm (kW)	fra (kN)	N2 (rpm)	i (:1)	M2 (Nm)	Pm (kW)	fra (kN)
1 1 c	2900	2.59	1119	225	0.064	6.00	2.63	1102	440	0.13	6.00	2.48	1169	660	0.18	7.50
	1450	1.30		225	0.032	6.00	1.32		440	0.064	6.00	1.24		660	0.090	7.50
	960	0.858		225	0.021	6.00	0.871		440	0.042	6.00	0.821		660	0.060	7.50
	725	0.644		225	0.016	6.00	0.654		440	0.032	6.00	0.616		660	0.045	7.50
1 2 c	2900	2.45	1183	225	0.061	6.00	2.29	1267	440	0.11	6.00	2.36	1231	660	0.17	7.50
	1450	1.23		225	0.030	6.00	1.14		440	0.055	6.00	1.18		660	0.086	7.50
	960	0.812		225	0.020	6.00	0.758		440	0.037	6.00	0.780		660	0.057	7.50
	725	0.609		225	0.015	6.00	0.568		440	0.028	6.00	0.585		660	0.043	7.50
1 4 c	2900	2.04	1423	225	0.051	6.00	2.03	1427	440	0.099	6.00	1.96	1477	660	0.14	7.50
	1450	1.02		225	0.025	6.00	1.02		440	0.049	6.00	0.98		660	0.071	7.50
	960	0.675		225	0.017	6.00	0.673		440	0.033	6.00	0.650		660	0.047	7.50
	725	0.506		225	0.013	6.00	0.505		440	0.024	6.00	0.487		660	0.035	7.50
1 6 c	2900	1.83	1583	225	0.045	6.00	1.81	1606	440	0.088	6.00	1.84	1577	660	0.13	7.50
	1450	0.916		225	0.023	6.00	0.903		440	0.044	6.00	0.919		660	0.067	7.50
	960	0.607		225	0.015	6.00	0.598		440	0.029	6.00	0.609		660	0.044	7.50
	725	0.455		225	0.011	6.00	0.448		440	0.022	6.00	0.457		660	0.033	7.50
1 8 c	2900	1.61	1800	225	0.040	6.00	1.63	1784	440	0.079	6.00	1.63	1777	660	0.12	7.50
	1450	0.805		225	0.020	6.00	0.813		440	0.039	6.00	0.816		660	0.059	7.50
	960	0.533		225	0.013	6.00	0.538		440	0.026	6.00	0.540		660	0.039	7.50
	725	0.400		225	0.010	6.00	0.404		440	0.020	6.00	0.405		660	0.029	7.50
2 0 c	2900	1.45	2000	225	0.036	6.00	1.47	2250	440	0.071	6.00	1.48	1957	660	0.11	7.50
	1450	0.725		225	0.018	6.00	0.644		440	0.036	6.00	0.741		660	0.054	7.50
	960	0.480		225	0.012	6.00	0.427		440	0.024	6.00	0.491		660	0.036	7.50
	725	0.360		225	0.009	6.00	0.320		440	0.018	6.00	0.368		660	0.027	7.50
2 2 c	2900	1.29	2250	225	0.032	6.00	1.28	2265	440	0.062	6.00	1.32	2205	660	0.096	7.50
	1450	0.644		225	0.016	6.00	0.640		440	0.031	6.00	0.658		660	0.048	7.50
	960	0.427		225	0.011	6.00	0.424		440	0.021	6.00	0.435		660	0.032	7.50
	725	0.320		225	0.008	6.00	0.318		440	0.015	6.00	0.327		660	0.024	7.50
2 5 c	2900	1.12	2579	225	0.028	6.00	1.18	2463	440	0.057	6.00	1.13	2563	660	0.082	7.50
	1450	0.562		225	0.014	6.00	0.589		440	0.029	6.00	0.566		660	0.041	7.50
	960	0.372		225	0.009	6.00	0.390		440	0.019	6.00	0.375		660	0.027	7.50
	725	0.279		225	0.007	6.00	0.292		440	0.014	6.00	0.281		660	0.020	7.50
2 8 c	2900	1.07	2699	225	0.027	6.00	1.04	2799	440	0.050	6.00	1.02	2847	660	0.074	7.50
	1450	0.537		225	0.013	6.00	0.518		440	0.025	6.00	0.509		660	0.037	7.50
	960	0.356		225	0.009	6.00	0.343		440	0.017	6.00	0.337		660	0.025	7.50
	725	0.267		225	0.007	6.00	0.257		440	0.012	6.00	0.253		660	0.018	7.50
3 2 c	2900	0.937	3094	225	0.023	6.00	0.863	3360	440	0.042	6.00	0.876	3310	660	0.064	7.50
	1450	0.469		225	0.012	6.00	0.432		440	0.021	6.00	0.438		660	0.032	7.50
	960	0.310		225	0.008	6.00	0.286		440	0.014	6.00	0.290		660	0.021	7.50
	725	0.233		225	0.006	6.00	0.214		440	0.010	6.00	0.218		660	0.016	7.50
3 6 c	2900	0.825	3516	225	0.020	6.00	0.817	3548	440	0.040	6.00	0.772	3757	660	0.056	7.50
	1450	0.412		225	0.010	6.00	0.409		440	0.020	6.00	0.386		660	0.028	7.50
	960	0.273		225	0.007	6.00	0.271		440	0.013	6.00	0.256		660	0.019	7.50
	725	0.205		225	0.005	6.00	0.203		440	0.010	6.00	0.192		660	0.014	7.50
4 0 c	2900	0.724	4007	225	0.018	6.00	0.725	3998	440	0.035	6.00	0.715	4056	660	0.052	7.50
	1450	0.362		225	0.009	6.00	0.363		440	0.018	6.00	0.357		660	0.026	7.50
	960	0.240		225	0.006	6.00	0.240		440	0.012	6.00	0.237		660	0.017	7.50
	725	0.180		225	0.004	6.00	0.180		440	0.009	6.00	0.178		660	0.013	7.50
4 5 c	2900	0.637	4554	225	0.016	6.00	0.638	4543	440	0.031	6.00	0.630	4604	660	0.046	7.50
	1450	0.318		225	0.008	6.00	0.319		440	0.015	6.00	0.315		660	0.023	7.50
	960	0.211		225	0.005	6.00	0.211		440	0.010	6.00	0.209		660	0.015	7.50
	725	0.158		225	0.004	6.00	0.158		440	0.008	6.00	0.156		660	0.011	7.50
5 0 c	2900	0.601	4826	187	0.012	6.00	0.624	4647	440	0.030	6.00	0.565	5131	660	0.041	7.50
	1450	0.300		187	0.006	6.00	0.312		440	0.015	6.00	0.283		660	0.021	7.50
	960	0.199		187	0.004	6.00	0.207		440	0.010	6.00	0.187		660	0.014	7.50
	725	0.149		187	0.003	6.00	0.155		440	0.008	6.00	0.140		660	0.010	7.50
5 6 c	2900	0.529	5485	187	0.011	6.00	0.549	5281	440	0.027	6.00	0.554	5234	660	0.040	7.50
	1450	0.264		187	0.005	6.00	0.275		440	0.013	6.00	0.277		660	0.020	7.50
	960	0.175		187	0.004	6.00	0.182		440	0.009	6.00	0.183		660	0.013	7.50
	725	0.131		187	0.003	6.00	0.136		440	0.007	6.00	0.138		660	0.010	7.50
6 3 c	2900	0.461	6286	160	0.008	6.00	0.484	5994	440	0.023	6.00	0.497	5833	660	0.036	7.50
	1450	0.231		160	0.004	6.00	0.242		440	0.012	6.00	0.249		660	0.018	7.50
	960	0.153		160	0.003	6.00	0.160		440	0.008	6.00	0.165		660	0.012	7.50
	725	0.115		160	0.002	6.00	0.120		440	0.006	6.00	0.123		660	0.009	7.50
7 1 c	2900	0.406	7144	158	0.007	6.00	0.426	6815	440	0.021	6.00	0.443	6542	605	0.030	7.50
	1450	0.203		158	0.004	6.00	0.213		440	0.010	6.00	0.222		605	0.015	7.50
	960	0.134		158	0.002	6.00	0.141		440	0.007	6.00	0.147		605	0.010	7.50
	725	0.101		158	0.002	6.00	0.106		440	0.005	6.00	0.110		605	0.007	7.50

SERIES K

QUINTUPLE REDUCTION RATINGS SIZES K06 - K08

Note: Input Power, Pm may exceed thermal limit, Check thermal power page

Pm - Input Power (kW)
M2 - Output Torque (Nm)
i - Exact Ratio (:1)
N2 - Output Speed (rpm)
fra - Overhung Load (kN)

QUINTUPLE REDUCTION

Column Entry			Input Speed N1 (rpm)	K0652				K0752				K0852						
6	7	8		N2 (rpm)	i (:1)	M2 (Nm)	Pm (kW)	fra (kN)	N2 (rpm)	i (:1)	M2 (Nm)	Pm (kW)	fra (kN)	N2 (rpm)	i (:1)	M2 (Nm)	Pm (kW)	fra (kN)
1	2	5	2900	24.96	116	825	2.27	8.00	24.11	120	1600	4.25	15.0	21.94	132	2710	6.55	15.7
			1450	12.48		825	1.13	8.00	12.05		1600	2.13	15.0	10.97		2710	3.28	15.7
			960	8.26		825	0.75	8.00	7.98		1600	1.41	15.0	7.26		2710	2.17	15.7
			725	6.20		825	0.56	8.00	5.99		1600	1.06	15.0	5.45		2710	1.63	15.7
1	4	0	2900	20.70	140	825	1.88	8.00	21.73	133	1600	3.83	15.0	20.05	145	2710	5.99	15.7
			1450	10.35		825	0.94	8.00	10.86		1600	1.92	15.0	10.02		2710	2.99	15.7
			960	6.85		825	0.62	8.00	7.19		1600	1.27	15.0	6.64		2710	1.98	15.7
			725	5.14		825	0.47	8.00	5.39		1600	0.95	15.0	4.98		2710	1.49	15.7
1	6	0	2900	18.78	154	825	1.71	8.00	19.72	147	1600	3.48	15.0	17.72	164	2710	5.29	15.7
			1450	9.39		825	0.85	8.00	9.86		1600	1.74	15.0	8.86		2710	2.65	15.7
			960	6.22		825	0.57	8.00	6.53		1600	1.15	15.0	5.87		2710	1.75	15.7
			725	4.66		825	0.42	8.00	4.90		1600	0.86	15.0	4.40		2710	1.31	15.7
2	0	0	2900	14.22	204	825	1.29	8.00	13.74	211	1600	2.42	15.0	14.26	203	2420	3.80	15.7
			1450	7.11		825	0.65	8.00	6.87		1600	1.21	15.0	7.13		2420	1.90	15.7
			960	4.71		825	0.43	8.00	4.55		1600	0.80	15.0	4.72		2420	1.26	15.7
			725	3.53		825	0.32	8.00	3.41		1600	0.60	15.0	3.54		2420	0.94	15.7
2	5	0	2900	11.20	259	825	1.02	8.00	12.43	233	1600	2.19	15.0	12.72	228	2710	3.80	15.7
			1450	5.60		825	0.51	8.00	6.21		1600	1.10	15.0	6.36		2710	1.90	15.7
			960	3.71		825	0.34	8.00	4.11		1600	0.73	15.0	4.21		2710	1.26	15.7
			725	2.78		825	0.25	8.00	3.09		1600	0.54	15.0	3.16		2710	0.94	15.7
2	8	0	2900	9.86	294	825	0.90	8.00	10.94	265	1600	1.93	15.0	10.82	268	2710	3.23	15.7
			1450	4.93		825	0.45	8.00	5.47		1600	0.96	15.0	5.41		2710	1.62	15.7
			960	3.26		825	0.30	8.00	3.62		1600	0.64	15.0	3.58		2710	1.07	15.7
			725	2.45		825	0.22	8.00	2.72		1600	0.48	15.0	2.69		2710	0.80	15.7
3	2	0	2900	9.34	310	825	0.85	8.00	9.52	305	1600	1.68	15.0	9.77	297	2710	2.92	15.7
			1450	4.67		825	0.42	8.00	4.76		1600	0.84	15.0	4.88		2710	1.46	15.7
			960	3.09		825	0.28	8.00	3.15		1600	0.56	15.0	3.23		2710	0.97	15.7
			725	2.32		825	0.21	8.00	2.36		1600	0.42	15.0	2.42		2710	0.72	15.7
3	6	0	2900	8.42	344	825	0.77	8.00	7.76	374	1600	1.37	15.0	8.61	337	2710	2.57	15.7
			1450	4.21		825	0.38	8.00	3.88		1600	0.68	15.0	4.31		2710	1.29	15.7
			960	2.79		825	0.25	8.00	2.57		1600	0.45	15.0	2.85		2710	0.85	15.7
			725	2.09		825	0.19	8.00	1.93		1600	0.34	15.0	2.14		2710	0.64	15.7
4	0	0	2900	7.41	391	825	0.67	8.00	6.99	415	1650	1.27	15.0	7.22	401	2710	2.16	15.7
			1450	3.71		825	0.34	8.00	3.50		1650	0.64	15.0	3.61		2710	1.08	15.7
			960	2.45		825	0.22	8.00	2.32		1650	0.42	15.0	2.39		2710	0.71	15.7
			725	1.84		825	0.17	8.00	1.74		1650	0.32	15.0	1.79		2710	0.54	15.7
4	5	0	2900	6.52	445	825	0.59	8.00	6.23	466	1650	1.13	15.0	6.27	462	2710	1.87	15.7
			1450	3.26		825	0.30	8.00	3.11		1650	0.57	15.0	3.14		2710	0.94	15.7
			960	2.16		825	0.20	8.00	2.06		1650	0.37	15.0	2.08		2710	0.62	15.7
			725	1.59		825	0.15	8.00	1.55		1650	0.28	15.0	1.56		2710	0.47	15.7
5	0	0	2900	5.92	489	825	0.54	8.00	5.65	513	1650	1.03	15.0	5.73	506	2710	1.71	15.7
			1450	2.96		825	0.27	8.00	2.83		1650	0.51	15.0	2.87		2710	0.86	15.7
			960	1.96		825	0.18	8.00	1.87		1650	0.34	15.0	1.90		2710	0.57	15.7
			725	1.47		825	0.13	8.00	1.40		1650	0.26	15.0	1.42		2710	0.43	15.7
5	6	0	2900	5.15	563	825	0.47	8.00	4.92	590	1650	0.89	15.0	5.39	538	2710	1.61	15.7
			1450	2.58		825	0.23	8.00	2.46		1650	0.45	15.0	2.70		2710	0.81	15.7
			960	1.71		825	0.16	8.00	1.63		1650	0.30	15.0	1.79		2710	0.53	15.7
			725	1.28		825	0.12	8.00	1.22		1650	0.22	15.0	1.34		2710	0.40	15.7
6	3	0	2900	4.74	612	825	0.43	8.00	4.52	641	1650	0.82	15.0	4.52	641	2710	1.35	15.7
			1450	2.37		825	0.22	8.00	2.26		1650	0.41	15.0	2.26		2710	0.68	15.7
			960	1.57		825	0.14	8.00	1.50		1650	0.27	15.0	1.50		2710	0.45	15.7
			725	1.18		825	0.11	8.00	1.12		1650	0.20	15.0	1.12		2710	0.34	15.7
7	0	0	2900	4.07	712	825	0.37	8.00	3.93	737	1650	0.72	15.0	3.82	760	2710	1.14	15.7
			1450	2.04		825	0.19	8.00	1.97		1650	0.36	15.0	1.91		2710	0.57	15.7
			960	1.35		825	0.12	8.00	1.30		1650	0.24	15.0	1.26		2710	0.38	15.7
			725	1.01		825	0.092	8.00	0.98		1650	0.18	15.0	0.95		2710	0.28	15.7
8	0	0	2900	3.64	797	825	0.33	8.00	3.47	836	1650	0.63	15.0	3.57	811	2710	1.07	15.7
			1450	1.82		825	0.17	8.00	1.73		1650	0.32	15.0	1.79		2710	0.53	15.7
			960	1.21		825	0.11	8.00	1.15		1650	0.21	15.0	1.18		2710	0.35	15.7
			725	0.904		825	0.082	8.00	0.861		1650	0.16	15.0	0.887		2710	0.27	15.7
9	0	0	2900	3.29	882	825	0.30	8.00	3.14	924	1650	0.57	15.0	3.27	888	2710	0.98	15.7
			1450	1.64		825	0.15	8.00	1.57		1650	0.29	15.0	1.63		2710	0.49	15.7
			960	1.09		825	0.099	8.00	1.04		1650	0.19	15.0	1.08		2710	0.32	15.7
			725	0.816		825	0.074	8.00	0.779		1650	0.14	15.0	0.811		2710	0.24	15.7
1	0	c	2900	2.83	1026	825	0.26	8.00	2.73	1062	1650	0.50	15.0	2.88	1007	2710	0.86	15.7
			1450	1.41		825	0.13	8.00	1.37		1650	0.25	15.0	1.44		2710	0.43	15.7
			960	0.936		825	0.085	8.00	0.904		1650	0.16	15.0	0.954		2710	0.28	15.7
			725	0.702		825	0.064	8.00	0.678		1650	0.12	15.0	0.715		2710	0.21	15.7

SERIES K

QUINTUPLE REDUCTION RATINGS SIZES K06 - K08

Note: Input Power, Pm may exceed thermal limit, Check thermal power page

Pm - Input Power (kW)
M2 - Output Torque (Nm)
i - Exact Ratio (:1)
N2 - Output Speed (rpm)
fra - Overhung Load (kN)

QUINTUPLE REDUCTION

Column Entry	Input Speed N1 (rpm)	K0652					K0752					K0852				
		N2 (rpm)	i (:1)	M2 (Nm)	Pm (kW)	fra (kN)	N2 (rpm)	i (:1)	M2 (Nm)	Pm (kW)	fra (kN)	N2 (rpm)	i (:1)	M2 (Nm)	Pm (kW)	fra (kN)
1 1 c	2900	2.53	1147	825	0.23	8.00	2.41	1204	1650	0.44	15.0	2.63	1102	2710	0.79	15.7
	1450	1.26		825	0.11	8.00	1.20		1650	0.22	15.0	1.32		2710	0.39	15.7
	960	0.837		825	0.076	8.00	0.797		1650	0.15	15.0	0.871		2710	0.26	15.7
	725	0.627		825	0.057	8.00	0.598		1650	0.11	15.0	0.654		2710	0.20	15.7
1 2 c	2900	2.40	1208	825	0.22	8.00	2.29	1267	1650	0.42	15.0	2.33	1246	2710	0.69	15.7
	1450	1.20		825	0.11	8.00	1.14		1650	0.21	15.0	1.16		2710	0.35	15.7
	960	0.795		825	0.072	8.00	0.757		1650	0.14	15.0	0.770		2710	0.23	15.7
	725	0.596		825	0.054	8.00	0.568		1650	0.10	15.0	0.578		2710	0.17	15.7
1 4 c	2900	2.00	1449	825	0.18	8.00	1.91	1521	1650	0.35	15.0	1.97	1470	2710	0.59	15.7
	1450	1.00		825	0.091	8.00	0.95		1650	0.17	15.0	0.99		2710	0.29	15.7
	960	0.662		825	0.060	8.00	0.631		1650	0.11	15.0	0.653		2710	0.20	15.7
	725	0.497		825	0.045	8.00	0.473		1650	0.086	15.0	0.490		2710	0.15	15.7
1 6 c	2900	1.87	1548	825	0.17	8.00	1.69	1720	1650	0.31	15.0	1.75	1659	2710	0.52	15.7
	1450	0.937		825	0.085	8.00	0.843		1650	0.15	15.0	0.874		2710	0.26	15.7
	960	0.620		825	0.056	8.00	0.558		1650	0.10	15.0	0.579		2710	0.17	15.7
	725	0.465		825	0.042	8.00	0.419		1650	0.076	15.0	0.434		2710	0.13	15.7
1 8 c	2900	1.66	1744	825	0.15	8.00	1.50	1938	1650	0.27	15.0	1.60	1817	2710	0.48	15.7
	1450	0.832		825	0.076	8.00	0.748		1650	0.14	15.0	0.798		2710	0.24	15.7
	960	0.551		825	0.050	8.00	0.495		1650	0.090	15.0	0.528		2710	0.16	15.7
	725	0.413		825	0.038	8.00	0.372		1650	0.068	15.0	0.396		2710	0.12	15.7
2 0 c	2900	1.51	1920	825	0.14	8.00	1.45	1994	1650	0.26	15.0	1.44	2011	2710	0.43	15.7
	1450	0.755		825	0.069	8.00	0.727		1650	0.13	15.0	0.721		2710	0.22	15.7
	960	0.500		825	0.045	8.00	0.482		1650	0.088	15.0	0.477		2710	0.14	15.7
	725	0.375		825	0.034	8.00	0.361		1650	0.066	15.0	0.358		2710	0.11	15.7
2 2 c	2900	1.34	2164	825	0.12	8.00	1.29	2246	1650	0.23	15.0	1.32	2202	2710	0.39	15.7
	1450	0.670		825	0.061	8.00	0.645		1650	0.12	15.0	0.658		2710	0.20	15.7
	960	0.444		825	0.040	8.00	0.427		1650	0.078	15.0	0.436		2710	0.13	15.7
	725	0.333		825	0.030	8.00	0.321		1650	0.058	15.0	0.327		2710	0.098	15.7
2 5 c	2900	1.15	2515	825	0.10	8.00	1.11	2611	1650	0.20	15.0	1.07	2699	2710	0.32	15.7
	1450	0.576		825	0.052	8.00	0.555		1650	0.10	15.0	0.537		2710	0.16	15.7
	960	0.382		825	0.035	8.00	0.368		1650	0.067	15.0	0.356		2710	0.11	15.7
	725	0.286		825	0.026	8.00	0.276		1650	0.050	15.0	0.267		2710	0.080	15.7
2 8 c	2900	1.04	2794	825	0.094	8.00	0.99	2934	1650	0.18	15.0	1.03	2821	2710	0.31	15.7
	1450	0.519		825	0.047	8.00	0.494		1650	0.090	15.0	0.514		2710	0.15	15.7
	960	0.344		825	0.031	8.00	0.327		1650	0.060	15.0	0.340		2710	0.10	15.7
	725	0.258		825	0.023	8.00	0.245		1650	0.045	15.0	0.255		2710	0.076	15.7
3 2 c	2900	0.893	3248	825	0.081	8.00	0.850	3411	1650	0.15	15.0	0.921	3147	2710	0.28	15.7
	1450	0.446		825	0.041	8.00	0.425		1650	0.077	15.0	0.461		2710	0.14	15.7
	960	0.296		825	0.027	8.00	0.281		1650	0.051	15.0	0.305		2710	0.091	15.7
	725	0.222		825	0.020	8.00	0.211		1650	0.038	15.0	0.229		2710	0.068	15.7
3 6 c	2900	0.787	3686	825	0.072	8.00	0.749	3871	1650	0.14	15.0	0.753	3853	2710	0.22	15.7
	1450	0.393		825	0.036	8.00	0.375		1650	0.068	15.0	0.376		2710	0.11	15.7
	960	0.260		825	0.024	8.00	0.248		1650	0.045	15.0	0.249		2710	0.074	15.7
	725	0.195		825	0.018	8.00	0.186		1650	0.034	15.0	0.187		2710	0.056	15.7
4 0 c	2900	0.729	3981	825	0.066	8.00	0.709	4093	1650	0.13	15.0	0.684	4237	2710	0.20	15.7
	1450	0.364		825	0.033	8.00	0.354		1650	0.064	15.0	0.342		2710	0.10	15.7
	960	0.241		825	0.022	8.00	0.235		1650	0.043	15.0	0.227		2710	0.068	15.7
	725	0.181		825	0.016	8.00	0.176		1650	0.032	15.0	0.170		2710	0.051	15.7
4 5 c	2900	0.642	4518	825	0.058	8.00	0.624	4646	1650	0.11	15.0	0.614	4722	2710	0.18	15.7
	1450	0.321		825	0.029	8.00	0.312		1650	0.057	15.0	0.307		2710	0.092	15.7
	960	0.212		825	0.019	8.00	0.207		1650	0.038	15.0	0.203		2710	0.061	15.7
	725	0.159		825	0.014	8.00	0.155		1650	0.028	15.0	0.152		2710	0.046	15.7
5 0 c	2900	0.576	5036	825	0.052	8.00	0.549	5281	1650	0.10	15.0	0.562	5157	2710	0.17	15.7
	1450	0.288		825	0.026	8.00	0.275		1650	0.050	15.0	0.281		2710	0.084	15.7
	960	0.191		825	0.017	8.00	0.182		1650	0.033	15.0	0.186		2710	0.056	15.7
	725	0.143		825	0.013	8.00	0.136		1650	0.025	15.0	0.140		2710	0.042	15.7
5 6 c	2900	0.565	5136	825	0.051	8.00	0.543	5345	1650	0.10	15.0	0.548	5296	2710	0.16	15.7
	1450	0.282		825	0.026	8.00	0.271		1650	0.049	15.0	0.274		2710	0.082	15.7
	960	0.187		825	0.017	8.00	0.180		1650	0.033	15.0	0.181		2710	0.054	15.7
	725	0.140		825	0.013	8.00	0.135		1650	0.024	15.0	0.136		2710	0.041	15.7
6 3 c	2900	0.507	5725	825	0.046	8.00	0.477	6076	1650	0.087	15.0	0.501	5783	2710	0.15	15.7
	1450	0.253		825	0.023	8.00	0.239		1650	0.043	15.0	0.251		2710	0.075	15.7
	960	0.168		825	0.015	8.00	0.158		1650	0.029	15.0	0.166		2710	0.050	15.7
	725	0.126		825	0.011	8.00	0.118		1650	0.022	15.0	0.124		2710	0.037	15.7
7 1 c	2900	0.452	6420	605	0.030	8.00	0.430	6752	1360	0.064	15.0	0.435	6660	2710	0.13	15.7
	1450	0.226		605	0.015	8.00	0.215		1360	0.032	15.0	0.218		2710	0.065	15.7
	960	0.150		605	0.010	8.00	0.142		1360	0.021	15.0	0.144		2710	0.043	15.7
	725	0.112		605	0.007	8.00	0.107		1360	0.016	15.0	0.108		2710	0.032	15.7

SERIES K

QUINTUPLE REDUCTION RATINGS

SIZES K09 - K12

Note: Input Power, Pm may exceed thermal limit, Check thermal power page

Pm - Input Power (kW)
 M2 - Output Torque (Nm)
 i - Exact Ratio (:1)
 N2 - Output Speed (rpm)
 fra - Overhung Load (kN)

QUINTUPLE REDUCTION

Column Entry			Input Speed N1 (rpm)	K0951				K1051				K1251						
				N2 (rpm)	i (:1)	M2 (Nm)	Pm (kW)	fra (kN)	N2 (rpm)	i (:1)	M2 (Nm)	Pm (kW)	fra (kN)	N2 (rpm)	i (:1)	M2 (Nm)	Pm (kW)	fra (kN)
6	7	8																
1	2	5	2900															
			1450															
			960															
			725															
1	4	0	2900															
			1450															
			960															
			725															
1	6	0	2900	18.02	161	4110	8.16	34.0	17.38	167	7250	13.89	43.1	16.85	172	12100	22.47	61.3
			1450	9.01		4110	4.08	34.0	8.69		7250	6.94	43.1	8.42		12100	11.23	61.3
			960	5.97		4110	2.70	34.0	5.75		7250	4.60	43.1	5.58		12100	7.44	61.3
			725	4.47		4110	2.03	34.0	4.32		7250	3.45	43.1	4.18		12100	5.58	61.3
2	0	0	2900	12.82	226	4300	6.07	34.0	12.82	226	7250	10.03	43.1	10.79	238	12100	14.39	61.3
			1450	6.41		4300	3.04	34.0	6.41		7250	5.01	43.1	5.39		12100	7.19	61.3
			960	4.24		4300	2.01	34.0	4.24		7250	3.32	43.1	3.57		12100	4.76	61.3
			725	3.18		4300	1.51	34.0	3.18		7250	2.49	43.1	2.68		12100	3.57	61.3
2	5	0	2900	11.44	254	4110	5.18	34.0	11.17	260	7250	8.93	43.1	12.16	269	12100	16.22	61.3
			1450	5.72		4110	2.59	34.0	5.59		7250	4.46	43.1	6.08		12100	8.11	61.3
			960	3.79		4110	1.71	34.0	3.70		7250	2.96	43.1	4.03		12100	5.37	61.3
			725	2.84		4110	1.29	34.0	2.77		7250	2.22	43.1	3.02		12100	4.03	61.3
2	8	0	2900	10.29	282	4300	4.88	34.0	10.16	285	7250	8.12	43.1	9.60	302	12100	12.81	61.3
			1450	5.15		4300	2.44	34.0	5.08		7250	4.06	43.1	4.80		12100	6.40	61.3
			960	3.41		4300	1.61	34.0	3.36		7250	2.69	43.1	3.18		12100	4.24	61.3
			725	2.56		4300	1.21	34.0	2.52		7250	2.02	43.1	2.38		12100	3.18	61.3
3	2	0	2900	9.72	298	4300	4.61	34.0	9.14	317	7250	7.31	43.1	8.74	332	12100	11.65	61.3
			1450	4.86		4300	2.30	34.0	4.57		7250	3.65	43.1	4.37		12100	5.83	61.3
			960	3.22		4300	1.53	34.0	3.03		7250	2.42	43.1	2.89		12100	3.86	61.3
			725	2.41		4300	1.14	34.0	2.27		7250	1.81	43.1	2.17		12100	2.89	61.3
3	6	0	2900	8.75	331	4110	3.97	34.0	7.78	373	7250	6.22	43.1	7.54	385	12100	10.05	61.3
			1450	4.38		4110	1.98	34.0	3.89		7250	3.11	43.1	3.77		12100	5.03	61.3
			960	2.90		4110	1.31	34.0	2.57		7250	2.06	43.1	2.50		12100	3.33	61.3
			725	2.17		4110	0.98	34.0	1.93		7250	1.54	43.1	1.87		12100	2.50	61.3
4	0	0	2900	7.22	402	4110	3.27	34.0	7.00	414	7250	5.59	43.1	6.63	437	12100	8.84	61.3
			1450	3.61		4110	1.64	34.0	3.50		7250	2.80	43.1	3.32		12100	4.42	61.3
			960	2.39		4110	1.08	34.0	2.32		7250	1.85	43.1	2.19		12100	2.93	61.3
			725	1.79		4110	0.81	34.0	1.74		7250	1.39	43.1	1.65		12100	2.20	61.3
4	5	0	2900	6.37	455	4300	3.02	34.0	6.16	471	7250	4.92	43.1	5.88	493	12100	7.84	61.3
			1450	3.18		4300	1.51	34.0	3.08		7250	2.46	43.1	2.94		12100	3.92	61.3
			960	2.11		4300	1.00	34.0	2.04		7250	1.63	43.1	1.95		12100	2.60	61.3
			725	1.58		4300	0.75	34.0	1.53		7250	1.22	43.1	1.46		12100	1.95	61.3
5	0	0	2900	5.93	489	4300	2.81	34.0	5.63	515	7250	4.50	43.1	5.46	531	12100	7.28	61.3
			1450	2.97		4300	1.41	34.0	2.82		7250	2.25	43.1	2.73		12100	3.64	61.3
			960	1.96		4300	0.93	34.0	1.87		7250	1.49	43.1	1.81		12100	2.41	61.3
			725	1.47		4300	0.70	34.0	1.40		7250	1.12	43.1	1.36		12100	1.81	61.3
5	6	0	2900	5.15	563	4110	2.33	34.0	5.12	566	7250	4.09	43.1	4.96	584	12100	6.62	61.3
			1450	2.58		4110	1.17	34.0	2.56		7250	2.05	43.1	2.48		12100	3.31	61.3
			960	1.71		4110	0.77	34.0	1.70		7250	1.35	43.1	1.64		12100	2.19	61.3
			725	1.28		4110	0.58	34.0	1.27		7250	1.02	43.1	1.23		12100	1.64	61.3
6	3	0	2900	4.43	655	4110	2.01	34.0	4.46	651	7250	3.56	43.1	4.32	671	12100	5.76	61.3
			1450	2.22		4110	1.00	34.0	2.23		7250	1.78	43.1	2.16		12100	2.88	61.3
			960	1.47		4110	0.66	34.0	1.48		7250	1.18	43.1	1.43		12100	1.91	61.3
			725	1.10		4110	0.50	34.0	1.11		7250	0.88	43.1	1.07		12100	1.43	61.3
7	0	0	2900	3.99	727	4110	1.81	34.0	4.01	723	7250	3.21	43.1	3.83	757	12100	5.11	61.3
			1450	1.99		4110	0.90	34.0	2.01		7250	1.60	43.1	1.92		12100	2.56	61.3
			960	1.32		4110	0.60	34.0	1.33		7250	1.06	43.1	1.27		12100	1.69	61.3
			725	0.99		4110	0.45	34.0	1.00		7250	0.80	43.1	0.95		12100	1.27	61.3
8	0	0	2900	3.68	789	4300	1.74	34.0	3.70	783	7250	2.96	43.1	3.59	809	12300	4.86	61.3
			1450	1.84		4300	0.87	34.0	1.85		7250	1.48	43.1	1.79		12300	2.43	61.3
			960	1.22		4300	0.58	34.0	1.23		7250	0.98	43.1	1.19		12300	1.61	61.3
			725	0.913		4300	0.43	34.0	0.919		7250	0.73	43.1	0.890		12300	1.21	61.3
9	0	0	2900	3.08	940	4300	1.46	34.0	3.21	904	7250	2.56	43.1	3.06	946	12100	4.09	61.3
			1450	1.54		4300	0.73	34.0	1.60		7250	1.28	43.1	1.53		12100	2.04	61.3
			960	1.02		4300	0.48	34.0	1.06		7250	0.85	43.1	1.01		12100	1.35	61.3
			725	0.766		4300	0.36	34.0	0.796		7250	0.64	43.1	0.761		12100	1.01	61.3
1	0	c	2900	2.82	1028	4110	1.28	34.0	2.96	980	7250	2.37	43.1	2.87	1012	12300	3.89	61.3
			1450	1.41		4110	0.64	34.0	1.48		7250	1.18	43.1	1.43		12300	1.94	61.3
			960	0.934		4110	0.42	34.0	0.980		7250	0.78	43.1	0.949		12300	1.29	61.3
			725	0.701		4110	0.32	34.0	0.735		7250	0.59	43.1	0.712		12300	0.96	61.3

SERIES K

QUINTUPLE REDUCTION RATINGS

SIZES K09 - K12

Note: Input Power, Pm may exceed thermal limit, Check thermal power page

Pm - Input Power (kW)
 M2 - Output Torque (Nm)
 i - Exact Ratio (:1)
 N2 - Output Speed (rpm)
 fra - Overhung Load (kN)

QUINTUPLE REDUCTION

Column Entry	Input Speed N1 (rpm)	K0951					K1051					K1251				
		N2 (rpm)	i (:1)	M2 (Nm)	Pm (kW)	fra (kN)	N2 (rpm)	i (:1)	M2 (Nm)	Pm (kW)	fra (kN)	N2 (rpm)	i (:1)	M2 (Nm)	Pm (kW)	fra (kN)
6 7 8																
1 1 c	2900	2.60	1115	4300	1.23	34.0	2.48	1171	7250	1.98	43.1	2.54	1140	12300	3.45	61.3
	1450	1.30		4300	0.62	34.0	1.24		7250	0.99	43.1	1.27		12300	1.72	61.3
	960	0.861		4300	0.41	34.0	0.820		7250	0.66	43.1	0.842		12300	1.14	61.3
	725	0.646		4300	0.31	34.0	0.615		7250	0.49	43.1	0.631		12300	0.86	61.3
1 2 c	2900	2.44	1190	4300	1.16	34.0	2.29	1268	7250	1.83	43.1	2.37	1226	12100	3.16	61.3
	1450	1.22		4300	0.58	34.0	1.14		7250	0.91	43.1	1.18		12100	1.58	61.3
	960	0.807		4300	0.38	34.0	0.757		7250	0.60	43.1	0.783		12100	1.04	61.3
	725	0.605		4300	0.29	34.0	0.568		7250	0.45	43.1	0.588		12100	0.78	61.3
1 4 c	2900	1.96	1477	4300	0.93	34.0	1.97	1470	7250	1.58	43.1	1.91	1519	12300	2.59	61.3
	1450	0.98		4300	0.47	34.0	0.99		7250	0.79	43.1	0.95		12300	1.29	61.3
	960	0.650		4300	0.31	34.0	0.653		7250	0.52	43.1	0.632		12300	0.86	61.3
	725	0.488		4300	0.23	34.0	0.490		7250	0.39	43.1	0.474		12300	0.64	61.3
1 6 c	2900	1.77	1641	4300	0.84	34.0	1.77	1634	7250	1.42	43.1	1.69	1712	12300	2.30	61.3
	1450	0.884		4300	0.42	34.0	0.887		7250	0.71	43.1	0.847		12300	1.15	61.3
	960	0.585		4300	0.28	34.0	0.588		7250	0.47	43.1	0.561		12300	0.76	61.3
	725	0.439		4300	0.21	34.0	0.441		7250	0.35	43.1	0.421		12300	0.57	61.3
1 8 c	2900	1.67	1741	4300	0.79	34.0	1.65	1754	7250	1.32	43.1	1.60	1811	12300	2.17	61.3
	1450	0.833		4300	0.39	34.0	0.827		7250	0.66	43.1	0.801		12300	1.09	61.3
	960	0.551		4300	0.26	34.0	0.547		7250	0.44	43.1	0.530		12300	0.72	61.3
	725	0.413		4300	0.20	34.0	0.411		7250	0.33	43.1	0.398		12300	0.54	61.3
2 0 c	2900	1.50	1935	4300	0.71	34.0	1.49	1949	7250	1.19	43.1	1.42	2042	12300	1.93	61.3
	1450	0.750		4300	0.36	34.0	0.744		7250	0.59	43.1	0.710		12300	0.96	61.3
	960	0.496		4300	0.24	34.0	0.493		7250	0.39	43.1	0.470		12300	0.64	61.3
	725	0.372		4300	0.18	34.0	0.369		7250	0.30	43.1	0.353		12300	0.48	61.3
2 2 c	2900	1.37	2118	4300	0.65	34.0	1.36	2134	7250	1.09	43.1	1.30	2236	12300	1.76	61.3
	1450	0.684		4300	0.32	34.0	0.679		7250	0.54	43.1	0.649		12300	0.88	61.3
	960	0.453		4300	0.21	34.0	0.450		7250	0.36	43.1	0.429		12300	0.58	61.3
	725	0.340		4300	0.16	34.0	0.337		7250	0.27	43.1	0.322		12300	0.44	61.3
2 5 c	2900	1.12	2596	4300	0.53	34.0	1.13	2561	7250	0.90	43.1	1.08	2683	12300	1.47	61.3
	1450	0.559		4300	0.26	34.0	0.566		7250	0.45	43.1	0.540		12300	0.73	61.3
	960	0.370		4300	0.18	34.0	0.375		7250	0.30	43.1	0.358		12300	0.49	61.3
	725	0.277		4300	0.13	34.0	0.281		7250	0.22	43.1	0.268		12300	0.36	61.3
2 8 c	2900	1.06	2733	4300	0.50	34.0	1.04	2779	7250	0.83	43.1	1.00	2887	12300	1.36	61.3
	1450	0.531		4300	0.25	34.0	0.522		7250	0.42	43.1	0.502		12300	0.68	61.3
	960	0.351		4300	0.17	34.0	0.345		7250	0.28	43.1	0.332		12300	0.45	61.3
	725	0.263		4300	0.12	34.0	0.259		7250	0.21	43.1	0.249		12300	0.34	61.3
3 2 c	2900	0.969	2992	4300	0.46	34.0	0.953	3044	7250	0.76	43.1	0.917	3162	12300	1.24	61.3
	1450	0.485		4300	0.23	34.0	0.476		7250	0.38	43.1	0.459		12300	0.62	61.3
	960	0.321		4300	0.15	34.0	0.315		7250	0.25	43.1	0.304		12300	0.41	61.3
	725	0.241		4300	0.11	34.0	0.237		7250	0.19	43.1	0.228		12300	0.31	61.3
3 6 c	2900	0.791	3667	4300	0.37	34.0	0.794	3652	7250	0.63	43.1	0.764	3794	12300	1.04	61.3
	1450	0.395		4300	0.19	34.0	0.397		7250	0.32	43.1	0.382		12300	0.52	61.3
	960	0.262		4300	0.12	34.0	0.263		7250	0.21	43.1	0.253		12300	0.34	61.3
	725	0.196		4300	0.09	34.0	0.197		7250	0.16	43.1	0.190		12300	0.26	61.3
4 0 c	2900	0.716	4048	4300	0.34	34.0	0.689	4208	7250	0.55	43.1	0.686	4226	12300	0.93	61.3
	1450	0.358		4300	0.17	34.0	0.345		7250	0.28	43.1	0.343		12300	0.47	61.3
	960	0.237		4300	0.11	34.0	0.228		7250	0.18	43.1	0.227		12300	0.31	61.3
	725	0.178		4300	0.08	34.0	0.171		7250	0.14	43.1	0.170		12300	0.23	61.3
4 5 c	2900	0.643	4512	4300	0.30	34.0	0.599	4842	7250	0.48	43.1	0.596	4862	12300	0.81	61.3
	1450	0.321		4300	0.15	34.0	0.299		7250	0.24	43.1	0.298		12300	0.40	61.3
	960	0.213		4300	0.10	34.0	0.198		7250	0.16	43.1	0.197		12300	0.27	61.3
	725	0.160		4300	0.076	34.0	0.149		7250	0.12	43.1	0.148		12300	0.20	61.3
5 0 c	2900	0.573	5060	4300	0.27	34.0	0.539	5380	7250	0.43	43.1	0.568	5110	12100	0.76	61.3
	1450	0.287		4300	0.14	34.0	0.270		7250	0.22	43.1	0.284		12100	0.38	61.3
	960	0.190		4300	0.090	34.0	0.178		7250	0.14	43.1	0.188		12100	0.25	61.3
	725	0.142		4300	0.067	34.0	0.134		7250	0.11	43.1	0.141		12100	0.19	61.3
5 6 c	2900	0.501	5793	4110	0.23	34.0	0.496	5845	7250	0.40	43.1	0.493	5879	12100	0.66	61.3
	1450	0.250		4110	0.11	34.0	0.248		7250	0.20	43.1	0.247		12100	0.33	61.3
	960	0.166		4110	0.075	34.0	0.164		7250	0.13	43.1	0.163		12100	0.22	61.3
	725	0.124		4110	0.056	34.0	0.123		7250	0.10	43.1	0.122		12100	0.16	61.3
6 3 c	2900	0.467	6207	4300	0.22	34.0	0.443	6548	7250	0.35	43.1	0.436	6657	12300	0.59	61.3
	1450	0.234		4300	0.11	34.0	0.221		7250	0.18	43.1	0.218		12300	0.30	61.3
	960	0.155		4300	0.073	34.0	0.147		7250	0.12	43.1	0.144		12300	0.20	61.3
	725	0.116		4300	0.055	34.0	0.110		7250	0.088	43.1	0.108		12300	0.15	61.3
7 1 c	2900	0.415	6980	4300	0.20	34.0	0.399	7276	7250	0.32	43.1	0.409	7083	12300	0.56	61.3
	1450	0.208		4300	0.10	34.0	0.199		7250	0.16	43.1	0.205		12300	0.28	61.3
	960	0.138		4300	0.065	34.0	0.132		7250	0.11	43.1	0.136		12300	0.18	61.3
	725	0.103		4300	0.049	34.0	0.099		7250	0.079	43.1	0.102		12300	0.14	61.3

SERIES K

DIMENSIONS

TRIPLE REDUCTION

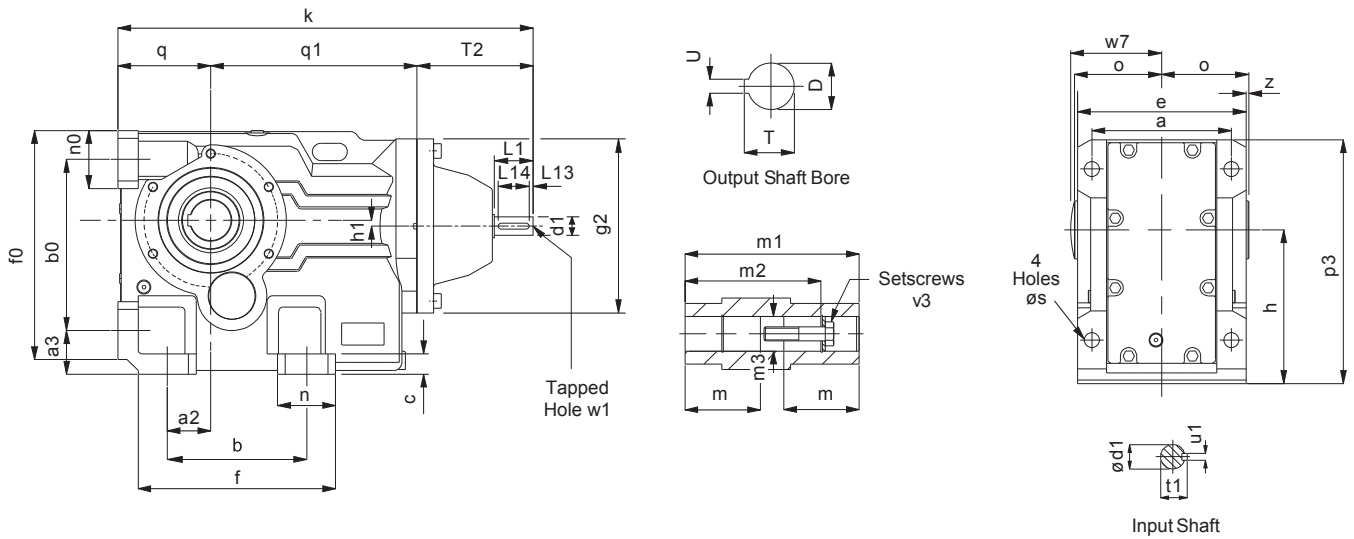

SIZE	a	a2	a3	b	b0	c	e	f	f0	g2	h	h1
K0332	100	28	32	110	115	11	120	143	152	140	100	16
K0432	120	35	37	130	130	16	145	168	171	140	112	13
K0532	130	30	45	130	150	15	157	170	192	180	132	5
K0632	140	30	45	120	160	20	170	176	208	180	140	13
K0732	165	40	55	150	200	27	200	210	263	212	180	25
K0832	180	55	70	180	233	30	230	256	309	250	212	15
K0931	240	75	75	240	295	35	290	340	395	300	265	10
K1031	270	95	95	280	360	40	340	390	455	360	315	41
K1231	330	115	110	350	420	45	400	470	540	400	375	65

SIZE	k	n	n0	o	p3	q	q1	T2	s	w7	z
K0332	333	38	38	60	167	63	159	111	11	63	0
K0432	361	38	40	75	187	71	179	111	11	78	2.5
K0532	410	40	40	83	217	80	219	111	14	87	4.5
K0632	430	55	48	90	233	90	229	111	14	94	5
K0732	492	60	55	105	288	112	265	115	18	109	5
K0832	622	76	76	120	341	132	330	160	23	124	5
K0931	710	100	100	150	420	160	355	195	27	154	5
K1031	856	110	115	175	513	200	423	233	34	180	5
K1231	987	120	120	205	590	225	476	286	39	210	5

SIZE	Input Shaft							Hollow Output Bore							
	d1	L1	L13	L14	t1	u1	w1	D	m	m1	m2	m3	T	U	v3
K0332	16 k6	40	4	32	18	5	M5x0.8, 12 deep	30	52.5	120	105	30.3	33.5	8	M10x50L
K0432	16 k6	40	4	32	18	5	M5x0.8, 12 deep	35	66	150	132	35.3	38.5	10	M12x55L
K0532	19 k6	40	4	32	21.5	6	M6x1.0, 16 deep	40	73	166	142	40.3	43.5	12	M16x70L
K0632	19 k6	40	4	32	21.5	6	M6x1.0, 16 deep	40	80	180	156	40.3	43.5	12	M16x70L
K0732	24 k6	50	5	40	27	8	M8x1.25, 19 deep	50	92.5	210	183	50.5	54	14	M16x70L
K0832	28 k6	60	5	50	31	8	M10x1.5, 22 deep	60	105	240	210	60.5	64.5	18	M20x80L
K0931	38 k6	80	5	70	41	10	M12x1.75, 28 deep	70	132.5	300	270	70.5	75	20	M20x80L
K1031	42 k6	110	10	70	45	12	M16x2.0, 36 deep	80	155	350	313	80.5	85.5	22	M20x80L
K1231	55 k6	110	10	90	59	16	M20x2.5, 42 deep	100	180	410	373	100.5	106.5	28	M24x110L

all parallel keys are to DIN 6885

SERIES K

DIMENSIONS

QUINTUPLE REDUCTION

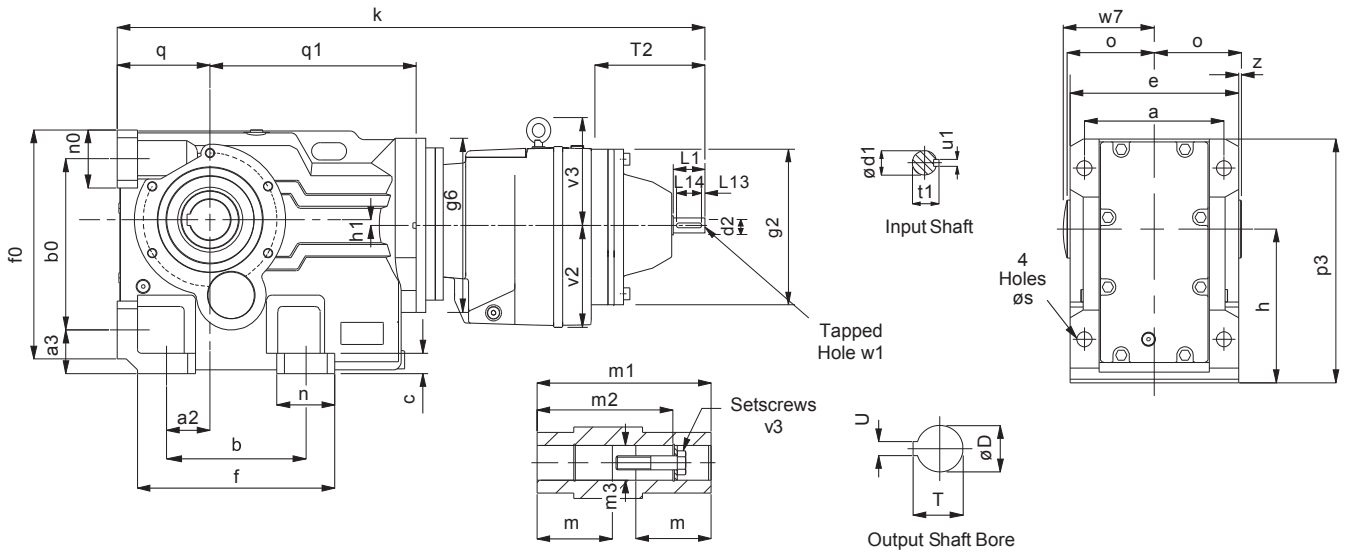

SIZE	a	a2	a3	b	b0	c	e	f	f0	g2	g6	h	h1
K0352	100	28	32	110	115	11	120	143	152	140	140	100	16
K0452	120	35	37	130	130	16	145	168	171	140	140	112	13
K0552	130	30	45	130	150	15	157	170	192	140	180	132	5
K0652	140	30	45	120	160	20	170	176	208	140	180	140	13
K0752	165	40	55	150	200	27	200	210	263	140	180	180	25
K0852	180	55	70	180	233	30	230	256	309	180	250	212	15
K0951	240	75	75	240	295	35	290	340	395	180	300	265	10
K1051	270	95	95	280	360	40	340	390	455	212	360	315	41
K1251	330	115	110	350	420	45	400	470	540	212	400	375	65

SIZE	k	n	n0	o	p3	q	q1	T2	s	w7	z	v2	v3
K0352	519	38	38	60	167	63	159	111	11	63	0	76	-
K0452	547	38	40	75	187	71	179	111	11	78	2.5	76	-
K0552	612	40	40	83	217	80	219	111	14	87	4.5	91	-
K0652	632	55	48	90	233	90	229	111	14	94	5	91	-
K0752	691	60	55	105	288	112	265	111	18	109	5	91	-
K0852	818	76	76	120	341	132	330	111	23	124	5	115	-
K0951	882	100	100	150	420	160	355	111	27	154	5	115	-
K1051	1030	115	110	175	513	200	423	115	34	180	5	140	155
K1251	1157	120	120	205	590	225	476	115	39	210	5	140	155

SIZE	Input Shaft							Hollow Output Bore							
	d1	L1	L13	L14	t1	u1	w1	D	m	m1	m2	m3	T	U	v3
K0332	16 k6	40	4	32	18	5	M5x0.8, 12 deep	30	52.5	120	105	30.3	33.5	8	M10x50L
K0432	16 k6	40	4	32	18	5	M5x0.8, 12 deep	35	66	150	132	35.3	38.5	10	M12x55L
K0532	16 k6	40	4	32	18	5	M5x0.8, 12 deep	40	73	166	142	40.3	43.5	12	M16x70L
K0632	16 k6	40	4	32	18	5	M5x0.8, 12 deep	40	80	180	156	40.3	43.5	12	M16x70L
K0732	16 k6	40	4	32	18	5	M5x0.8, 12 deep	50	92.5	210	183	50.5	54	14	M16x70L
K0832	19 k6	40	4	32	21.5	6	M6x1.0, 16 deep	60	105	240	210	60.5	64.5	18	M20x80L
K0931	19 k6	40	4	32	21.5	6	M6x1.0, 16 deep	70	132.5	300	270	70.5	75	20	M20x80L
K1031	24 k6	50	5	40	27	8	M8x1.25, 19 deep	80	155	350	313	80.5	85.5	22	M20x80L
K1231	24 k6	50	5	40	27	8	M8x1.25, 19 deep	100	180	410	373	100.5	106.5	28	M24x110L

all parallel keys are to DIN 6885

SERIES K

FAN COOLED UNITS

Column 10 Entry

For reducer fan kit modules enter **S** in column 10
or if used in conjunction with a reducer backstop module kit

Y
Z

CW rotation

CCW rotation

Dimensions of Fan Cooled Units

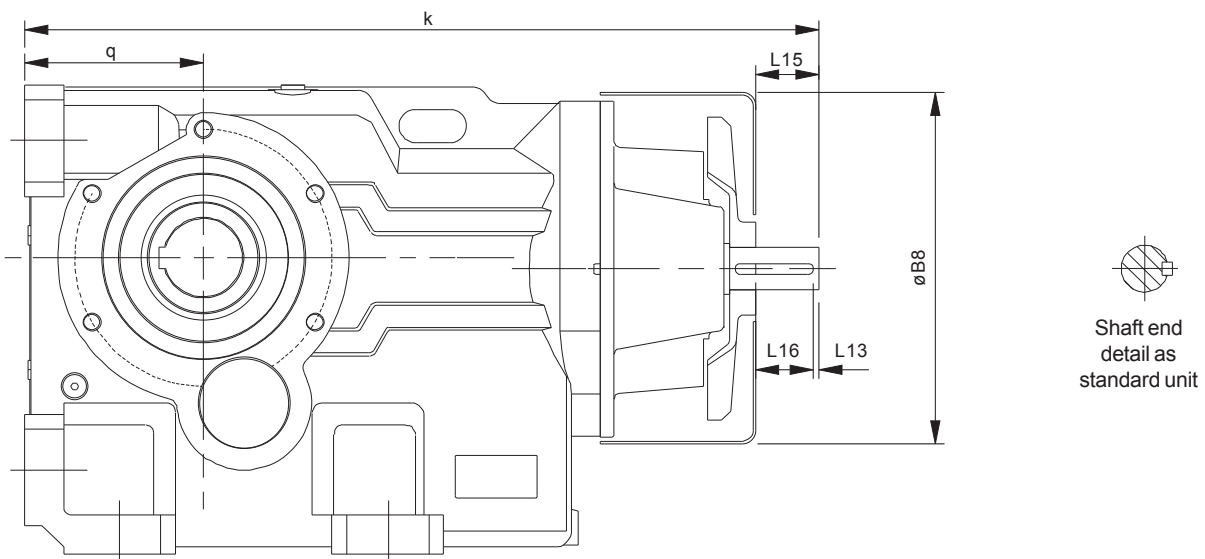

Unit Size	øB8	k	L13	L15	L16	q
K0732	225	492	5	35	30	112
K0832	265	622	5	45	40	132
K0931	320	710	5	65	60	160
K1031	380	856	10	95	85	200
K1231	420	987	10	85	75	225

SERIES K REDUCER BACKSTOP MODULE

The reducer units listed below can be fitted with an internal backstop, this has no effect of the external unit size. The backstop device incorporates high quality centrifugal lift off sprags which are wear free above the lift off speed (n min). To ensure correct operation input speed must exceed lift off speed.

Suitable for ambient temperature -40°C to + 50°C

Column 10 Entry

For reducer backstop modules enter W for CCW rotation (or Z if used in conjunction with a fan kit)
X for CW rotation (or Y if used in conjunction with a fan kit)

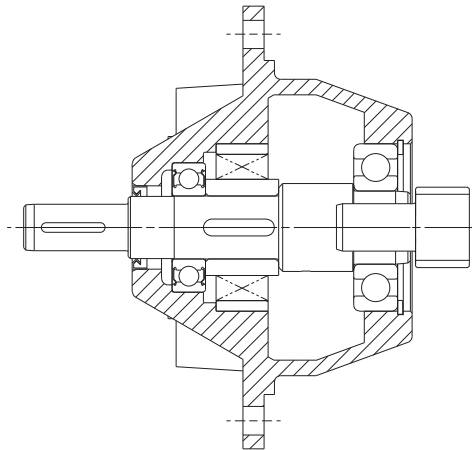

Unit Size	Lift off Speed ('n' min) (at inputshaft) (rev/min)	Rated Locking Torque ('T max') (at inputshaft) (Nm)
K0532	800	100
K0632	800	100
K0732	670	170
K0832	670	300
K0931	670	940
K1031	670	1260
K1231	550	2400

Rotation of outputshaft must be specified when ordering as viewed from the outputshaft end (as shown in the diagram)

CW	-	Free Rotation	-	Clockwise
		Locked		Anticlockwise
AC	-	Free Rotation	-	Anticlockwise
		Locked		Clockwise

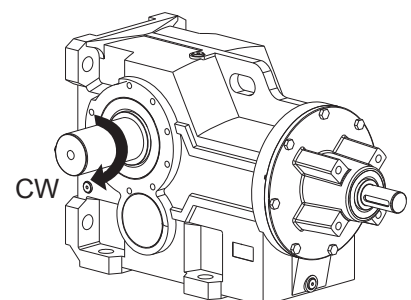

SERIES K

DIMENSIONS

OUTPUTSHAFT OPTIONS

STANDARD OUTPUTSHAFT OPTION

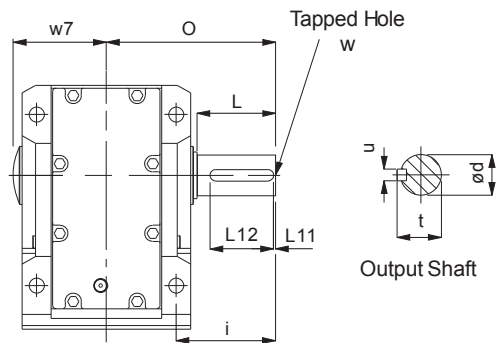

all parallel keys are to DIN 6885

SIZE	ød	i	L	L11	L12	O	t	u	w	w7
K0332	25.015 / 25.002	60	47	3	40	110	28	8	M10 x 1.5, 22 Deep	63
K0432	30.015 / 30.002	75	56	3	50	135	33	8	M12 x 1.75, 28 Deep	78
K0532	35.018 / 35.002	88	66	3	56	153	38	10	M16 x 2, 36 Deep	87
K0632	40.018 / 40.002	101	76	3	70	171	43	12	M16 x 2, 36 Deep	94
K0732	50.018 / 50.002	123.5	95	3	80	206	53.5	14	M16 x 2, 36 Deep	109
K0832	60.030 / 60.011	150	114	3	100	240	64	18	M20 x 2.5, 42 Deep	124
K0931	70.030 / 70.011	171	135	3	110	291	74.5	20	M20 x 2.5, 42 Deep	154
K1031	90.035 / 90.013	212	172	5	140	347	95	25	M20 x 2.5, 42 Deep	180
K1231	110.035 / 110.013	253	213	5	180	418	116	28	M24 x 3, 55 Deep	210

STANDARD DOUBLE EXTENDED OUTPUTSHAFT OPTION

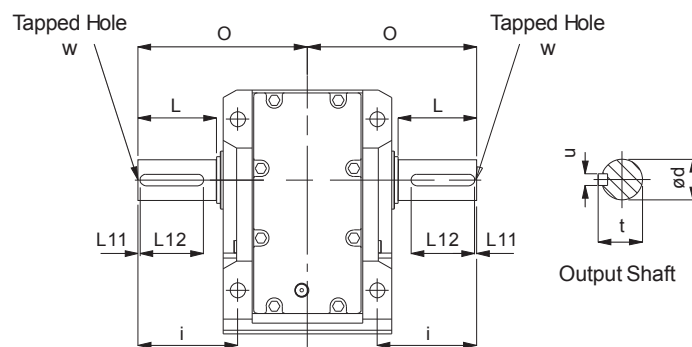

all parallel keys are to DIN 6885

SIZE	d	i	L	L11	L12	O	t	u	w
K0332	25.015 / 25.002	60	47	3	40	110	28	8	M10 x 1.5, 22 Deep
K0432	30.015 / 30.002	75	56	3	50	135	33	8	M12 x 1.75, 28 Deep
K0532	35.018 / 35.002	88	66	3	56	153	38	10	M16 x 2, 36 Deep
K0632	39.991 / 39.975	101	76	3	70	171	43	12	M16 x 2, 36 Deep
K0732	49.991 / 49.975	123.5	95	3	80	206	53.5	14	M16 x 2, 36 Deep
K0832	59.990 / 59.971	150	114	3	100	240	64	18	M20 x 2.5, 42 Deep
K0931	69.990 / 69.971	171	135	3	110	291	74.5	20	M20 x 2.5, 42 Deep
K1031	75.030 / 75.011	212	163	5	110	347	79.5	20	M20 x 2.5, 42 Deep
K1231	95.035 / 95.013	253	200	5	140	418	100	25	M20 x 2.5, 42 Deep

SERIES K DIMENSIONS SHRINK DISC

The gear unit is fitted with a 'shrink disc' device located on the hollow output shaft to provide a positive outer locking connection between gear unit and driven shaft. The 'shrink disc' is a friction device, without keys, which exerts an external clamping force on the hollow output shaft, thus establishing a mechanical shrink fit between the gear unit hollow shaft and driven shaft. 'Shrink disc' capacities have ample margins in dealing with transmitted torques and external loading imposed on gear units.

WORKING PRINCIPLE

The 'shrink disc' consists of a locking collar, a tapered inner ring and locking screws. By tightening the locking screws, the locking collar and tapered inner ring are pulled together, exerting radial forces on the inner ring, thus creating a positive friction connection between hollow shaft and driven shaft.

As the tapered surfaces of locking collar and inner ring are lubricated with Molykote 321R or similar and the taper angle is not self locking, locking collar will not seize on the inner ring and can be released easily when removal is necessary.

When the shrink disc is clamped in position the high contact pressures between tapered surfaces and screw heads and their seatings ensure hermetic sealing and eliminate the possibility of fretting corrosion.

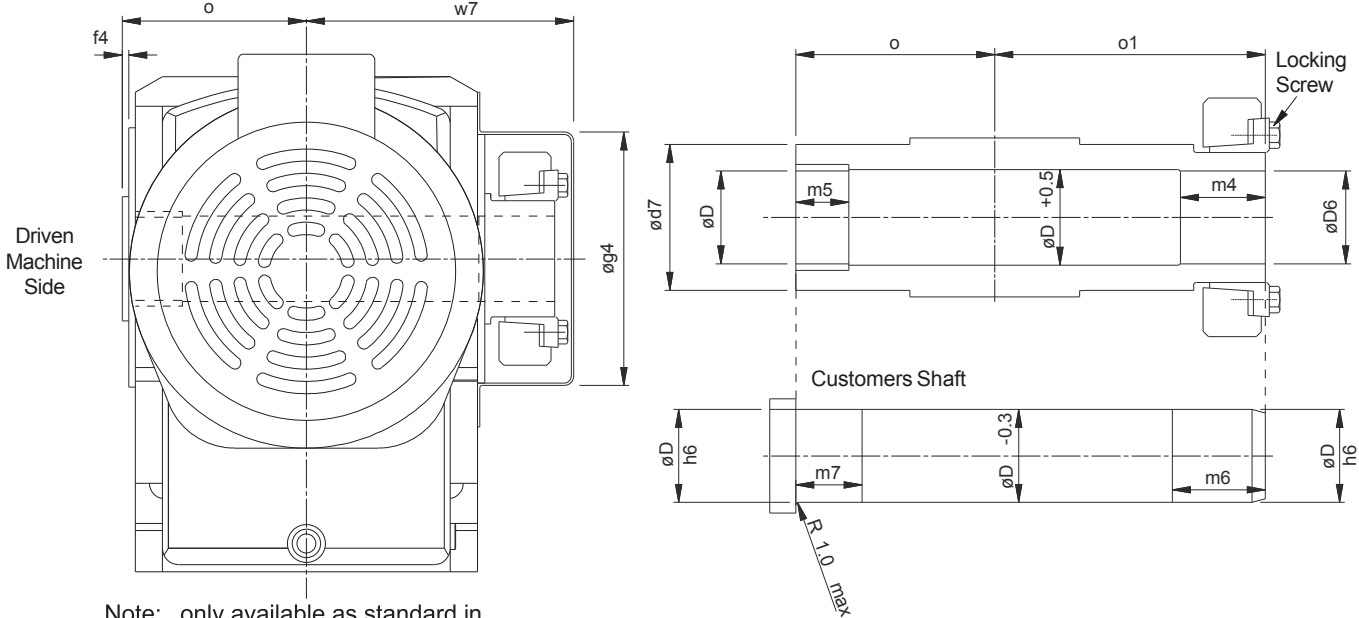

Note: only available as standard in this handing, please contact Application Engineering for opposite handing

SIZE	D	D6	d7	f4	g4	m4	m5	m6	m7	o	o1	w7	Locking Screws Torque Ta (Nm)
K03	30	30	50	2.5	88.5	31	20	36	25	60	86	91	29
K04	35	35	55	2.5	108	32	20	37	25	75	102	113	29
K05	40	40	60	3	108	36	20	41	25	83	112	118	29
K06	40	40	70	3.5	133	38	20	43	25	90	118	140	29
K07	50	50	80	6	133	36	30	41	35	105	136	152	35
K08	65	65	90	5	162	41	40	46	45	120	161	175	58
K09	75	75	100	5	192	55	40	60	55	150	195	210	58
K10	95	95	120	5	242	65	60	70	65	175	230	265	100
K12	105	105	140	5	242	85	60	90	75	205	280	295	160

SERIES K DIMENSIONS TORQUE BRACKET

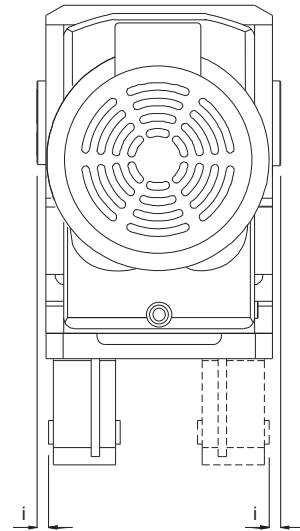
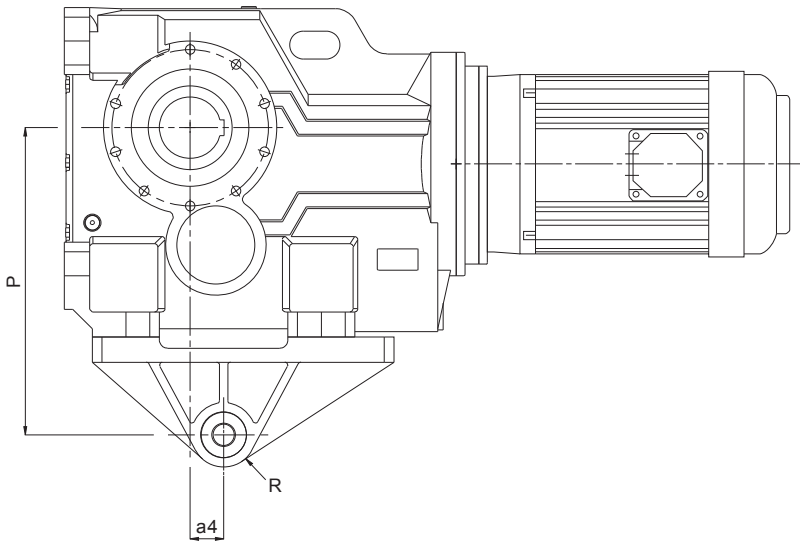

Column 9 Entry

T Torque bracket on left

Column 9 Entry

Q Torque bracket on right

The torque arm requires a Stirrup type anchoring

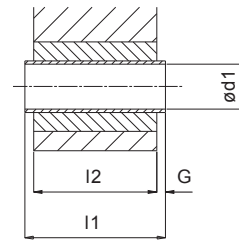
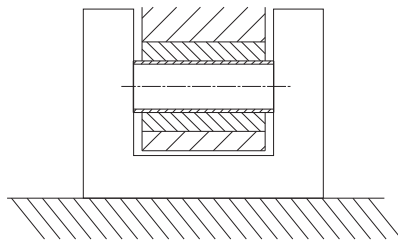

SIZE	a4	d1	G	i	l1	l2	P	R
K03	23.5	10.5 10.3	2	20	36	32	140	23
K04	30	10.5 10.3	2	20	36	32	160	23
K05	40	16.5 16.3	2	18	60	56	192	38
K06	45	16.5 16.3	2	25	60	56	200	38
K07	52.5	16.5 16.3	2	25	60	56	250	38
K08	60	25.25 24.75	5	30	80	70	300	45
K09	70	25.25 24.75	5	40	100	90	350	45
K10	74	25.25 24.75	5	45	100	90	450	45
K12	60	38.25 37.75	8	10	126	110	550	63

NOTES:

It is recommended that the torque arm is fitted on the side of the unit adjacent to the driven machine.

The use of a fitted bolt is recommended.

SERIES K

DIMENSIONS

D (B5) FLANGE

Sizes K09 to K12

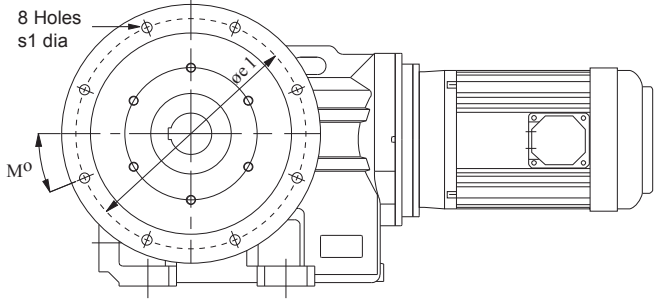

Sizes K03 to K08

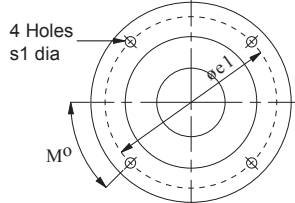

Column 9 Entry

F B5 (D) Output Flange on Left

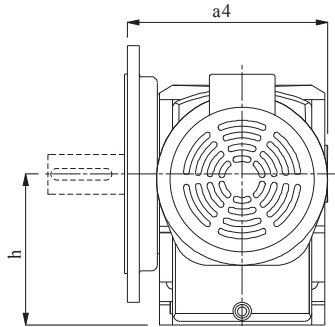

Column 9 Entry

H B5 (D) Output Flange on Right

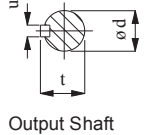
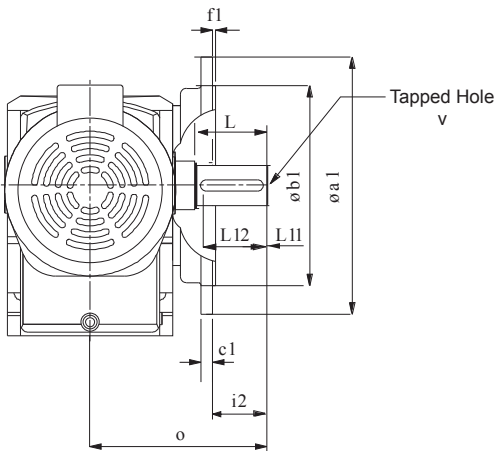

Output Shaft

SIZE	øa1	a4	øb1	c1	øe1	f1	h	m	øS1
K03	160	144	110 j6	10	130	3.5	100	45°	9
K04	200	190	130 j6	12	165	3.5	112	45°	11
K05	250	189	180 j6	16	215	4	132	45°	14
K06	250	220	180 j6	18	215	4	140	45°	14
K07	300	247	230 j6	18	265	4	180	45°	14
K08	350	285	250 h6	18	300	5	212	45°	18
K09	450	351	350 h6	20	400	5	265	22.5°	18
K10	450	410.5	350 h6	22	400	5	315	22.5°	18
K12	450	410.5	350 h6	22	400	5	375	22.5°	18

SIZE	Output Shaft								
	d	i2	L	L11	L12	o	t	u	v
K0332	25.015 / 25.002	26	47	3	40	110	28	8	M10 x 1.5, 22 Deep
K0432	30.015 / 30.002	20	56	3	50	135	33	8	M12 x 1.75, 28 Deep
K0532	35.018 / 35.002	47	66	3	60	153	38	10	M16 x 2, 36 Deep
K0632	40.018 / 40.002	41	76	3	70	171	43	12	M16 x 2, 36 Deep
K0732	50.018 / 50.002	64	95	3	80	206	53.5	14	M16 x 2, 36 Deep
K0832	60.030 / 60.011	75	114	3	100	240	64	18	M20 x 2.5, 42 Deep
K0931	70.030 / 70.011	90	135	3	110	291	74.5	20	M20 x 2.5, 42 Deep
K1031	90.035 / 90.013	112	172	5	140	347	95	25	M20 x 2.5, 42 Deep
K1231	110.035 / 110.013	150	213	5	180	418	116	28	M24 x 3, 55 Deep

SERIES K DIMENSIONS C (B14) FLANGE

K03, K04 & K08

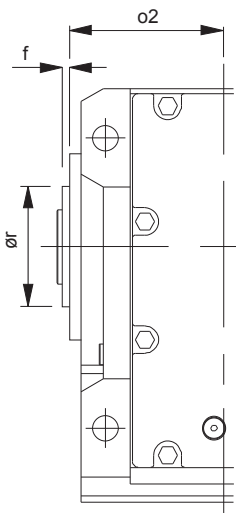
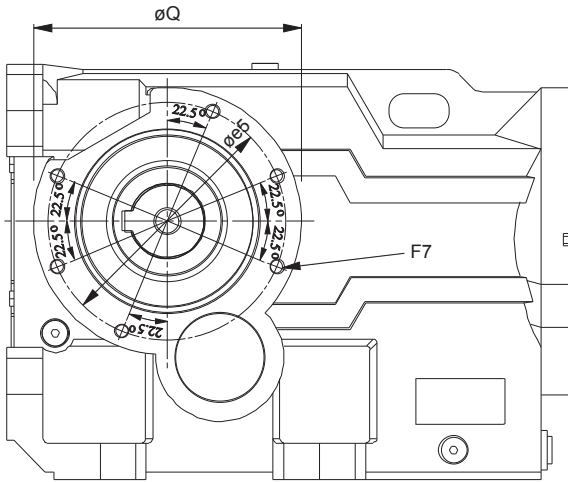

Male spigot
K03 - K07

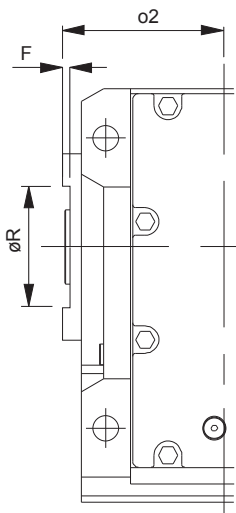

Female recess
K08 - K12

K05

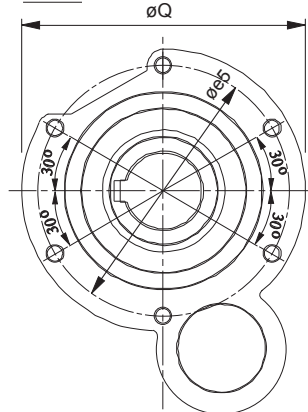

K06

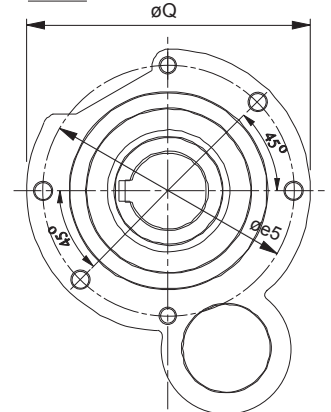

K07

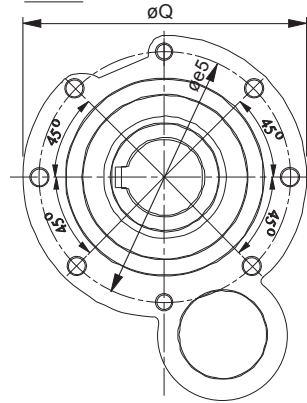

K09

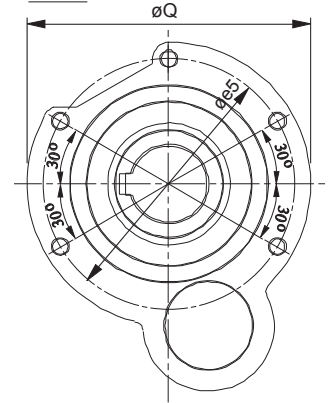

K10

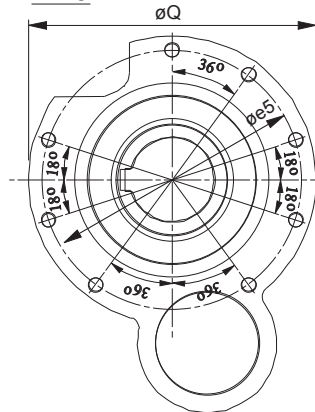

K12

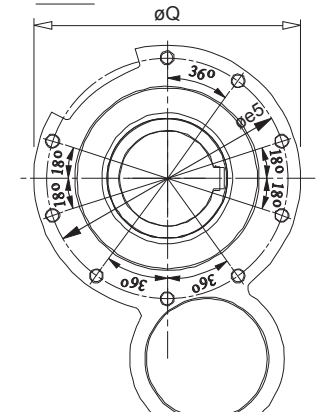

SIZE	$\phi e5$	F7	$o2$	Q	ϕr h7 spigot ϕ	ϕR H7	Spigot f	Recess F
K03	107 pcd	6 Holes M8 x 1.25, 12 Deep	55	122	85	-	2.5	-
K04	130 pcd	6 Holes M8 x 1.25, 12 Deep	70	146	105	-	2.5	-
K05	125 pcd	6 Holes M10 x 1.5, 17 Deep	75	150	105	-	3.0	-
K06	150 pcd	6 Holes M10 x 1.5, 17 Deep	83	180	130	-	3.5	-
K07	150 pcd	8 Holes M10 x 1.5, 17 Deep	95	180	130	-	6.0	-
K08	195 pcd	6 Holes M12 x 1.75, 20 Deep	115	220	-	150	-	5.0
K09	230 pcd	5 Holes M16 x 2.0, 27 Deep	145	260	-	180	-	6.0
K10	280 pcd	8 Holes M16 x 2.0, 27 Deep	170	310	-	210	-	7.0
K12	280 pcd	9 Holes M16 x 2.0, 27 Deep	200	310	-	210	-	7.0

SERIES K

DIMENSIONS STANDARD BORE ASSEMBLY

ASSEMBLY ONTO SHAFT - CUSTOMERS SHAFT DETAIL

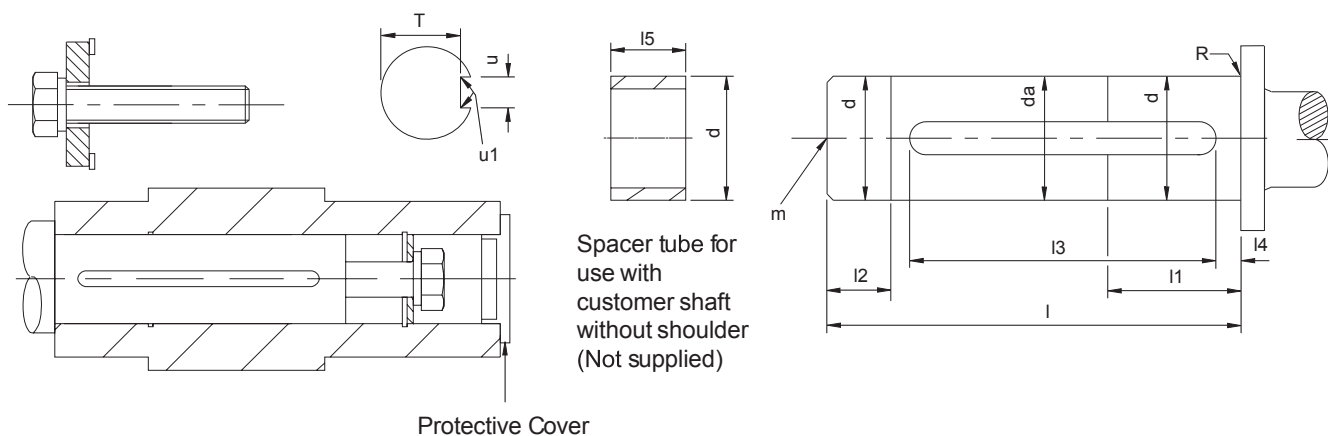

SIZE	d	da	l	l1	l2	l3	l4	l5	m	N	R	T	u	u1
K03	29.993/ 29.980	29.6	82	45	15	70.3 70.0	3	23	M10 x 1.5 22 deep	15 Nm	0.8R	26.0 25.8	8.000 / 7.964	0.16 0.25R
K04	34.991/ 34.975	34.6	109	60	20	90.5 90.0	3	23	M12 x 1.75 30 deep	20 Nm	0.8R	30.0 29.8	10.000 / 9.964	0.16 0.25R
K05	39.991/ 39.975	39.6	112	60	20	92.5 92.0	3	30	M16 x 2 38 deep	45 Nm	0.8R	35.0 34.8	12.000 / 11.957	0.4 0.25R
K06	39.991/ 39.975	39.6	126	75	25	100.5 100.0	3	30	M16 x 2 38 deep	45 Nm	0.8R	35.0 34.8	12.000 / 11.957	0.4 0.25R
K07	49.991/ 49.975	49.6	153	90	30	130.5 130.0	3	30	M16 x 2 38 deep	45 Nm	0.8R	44.5 44.3	14.000 / 13.957	0.4 0.25R
K08	59.990 / 59.971	59.6	173	90	30	148.5 148.0	3	37	M20x 2.5 42 deep	85 Nm	0.8R	53 52.8	18.000 / 17.957	0.4 0.25R
K09	69.990 / 69.971	69.6	232	105	35	161.5 161.0	3	38	M20 x 2.5P 42 deep	85 Nm	0.8R	62.5 62.3	20.000 / 19.948	0.6 0.4R
K10	79.990 / 79.971	79.6	275	120	40	188.5 188.0	5	37	M20 x 2.5P 42 deep	85 Nm	0.8R	71 70.8	22.000 / 21.948	0.6 0.4R
K12	99.988/ 99.966	99.6	327	150	50	238.5 238.0	10	46	M24 x 3 50 deep	200 Nm	0.8R	90 89.8	28.000/ 27.948	0.4

Assembly Instructions

1. Spray the hollow shaft bore and mating diameter of the output shaft with Rocol DFMS or equivalent anti-scuffing spray.
2. Fit key into shaft.
3. Fit the circlip into the output sleeve.
4. Fit the spacer tube only if the output shaft has no shoulder, then fit the output shaft into the output sleeve.
5. Secure in place with the washer and bolt. Torque tighten to the values stated in column N of the above table.
6. Fit plastic protective cover.

SERIES K

DIMENSIONS STANDARD

BORE DISASSEMBLY

DISASSEMBLY METHOD FROM SHAFT

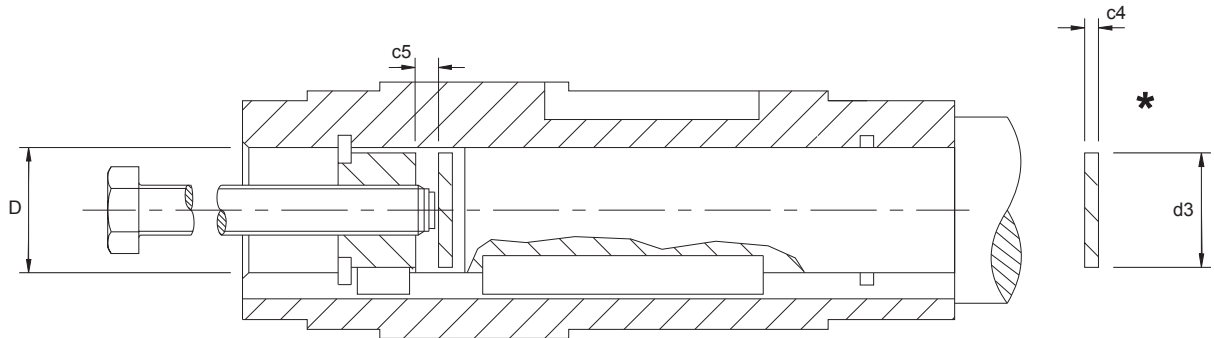

* PARTS SUPPLIED BY CUSTOMER

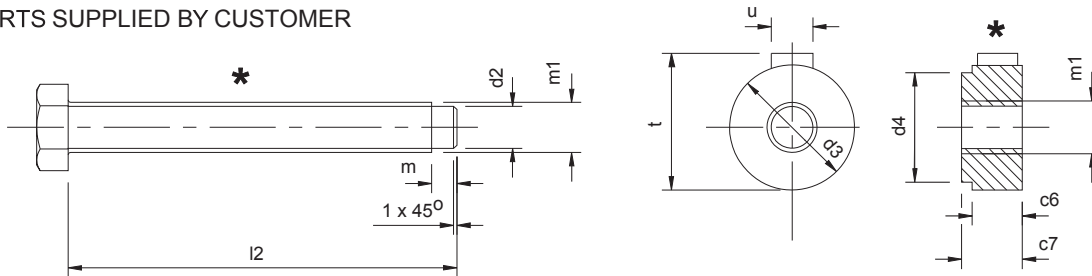

SIZE	c4	c5	c6	c7	D	d2	d3	d4	l2	m	m1	t	u
K03	5	3.00	15	17	30	13	29.9	20.8	130	3	M16 x 1.5	33	8
K04	5	3.00	15	17	35	13	34.9	25.2	160	3	M16 x 1.5	38	10
K05	5	4.00	20	23	40	20	39.9	29.9	190	3	M24 x 1.5	43	12
K06	5	4.00	20	23	40	20	39.9	29.9	190	3	M24 x 1.5	43	12
K07	5	4.00	20	23	50	20	49.9	39.0	220	3	M24 x 1.5	53.5	14
K08	8	5.00	24	27	60	26	59.9	47.4	250	5	M30 x 1.5	64	18
K09	8	6.05	24	27	70	26	69.9	56.4	310	5	M30 x 1.5	74.5	20
K10	8	6.00	24	27	80	26	79.9	65.5	360	5	M30 x 1.5	95	22
K12	8	8.00	30	34	100	32	99.9	84.1	420	5	M36 x 1.5	116	28

SERIES K

SHIPPING SPECIFICATION

UNIT SIZE & No OF REDUCTIONS		K0332	K0352	K0432	K0452	K0532	K0552	K0632	K0652	K0732	K0752	K0832	K0852	K0931	K0951	K1031	K1051	K1231	K1251		
REDUCER VERSION		16	24	21	29	32	43	40	51	61	70	113	139	174	197	306	321	458	485		
OUTPUT SHAFT		0.7	0.7	1.1	1.1	1.3	1.3	1.8	1.8	3.5	3.5	6.1	6.1	10.8	10.8	18.5	18.5	34.6	34.6		
OUTPUT FLANGE		1.3	1.3	2.8	2.8	4	4	5.4	5.4	7	7	15	15	17	17	26	26	26	26		
MOTORISED	63	Without Motor	16	25	21	30		44		52		70									
		With Motor	21	29	26	35		48		56		75									
	71	Without Motor	16	24	21	30		44		52		70									
		With Motor	22	31	28	36		50		58		76									
	80A	Without Motor	16	25	22	30	31	44	39	52	58	70	114	139	167	197		321		481	
		With Motor	26	34	31	40	41	54	49	62	67	80	123	148	176	206		331		491	
	80B	Without Motor	16	25	22	30	31	44	39	52	58	70	114	139	167	197		321		481	
		With Motor	27	36	33	41	42	55	50	63	69	81	125	150	178	208		332		492	
	90S	Without Motor	17	26	22	31	32	45	40	53	59	71	114	140	167	198		322		482	
		With Motor	31	39	36	44	46	58	54	66	72	85	127	153	180	211		336		496	
	90L	Without Motor	17	26	22	31	32	45	40	53	59	71	114	140	167	198		322		482	
		With Motor	32	40	37	45	47	59	55	67	73	86	128	154	181	212		337		497	
	100L	Without Motor	18		23		35		43		61		116	142	169	200	293	325	427	485	
		With Motor	42		47		59		67		85		140	166	193	224	317	349	451	509	
	112M	Without Motor	18		23		35		43		61		116	142	169	200	293	325	427	485	
		With Motor	45		34		66		74		92		147	173	200	231	324	356	458	516	
	132S	Without Motor									63		119		172		296	327	430	487	
		With Motor									111		167		220		344	375	478	535	
	132M	Without Motor									63		119		172		296	327	430	487	
		With Motor									115		171		224		348	379	482	539	
	160M	Without Motor											124		177		301		436		
		With Motor											219		272		396		531		
	160L	Without Motor											124		177		301		436		
		With Motor											237		290		414		549		
	180M	Without Motor													190		314		448		
		With Motor													357		481		615		
	180L	Without Motor													190		314		448		
		With Motor													371		495		629		
	200L	Without Motor													194		318		453		
		With Motor													426		550		685		
	225S	Without Motor													196		322		457		
		With Motor													485		609		744		
	225M	Without Motor													198		322		457		
		With Motor													520		644		779		
	250M	Without Motor																	471		
		With Motor																	856		
	280S	Without Motor																	471		
		With Motor																	981		
	280M	Without Motor																	471		
		With Motor																	1071		

ALL WEIGHTS EXCLUDE LUBRICANT AND ARE FOR STANDARD SHAFT MOUNT UNITS, FOR FLANGE OR BASE MOUNT UNITS ADD WEIGHT OF FLANGE / SHAFT (SHOWN AT TOP OF TABLE) TO THE FIGURES SHOWN ABOVE

ALL WEIGHTS IN KG

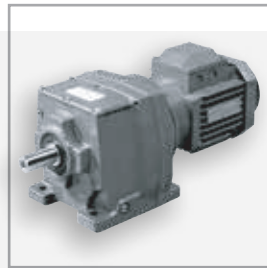
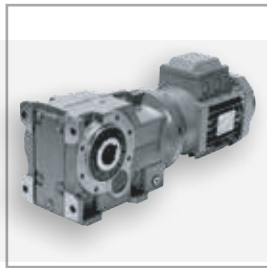
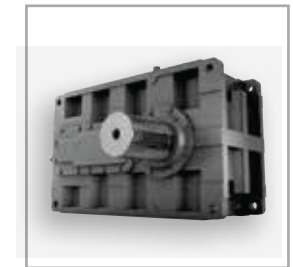
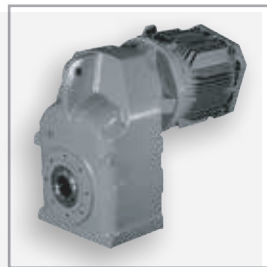
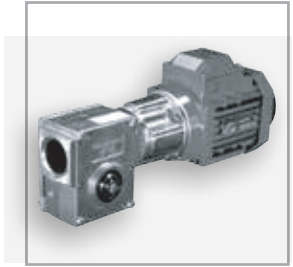

benzlers^{⚙️}
radicon^{⚙️}