

radicon

with you at every turn

Series M. C. F. K - Geared Motors
Installation & Maintenance

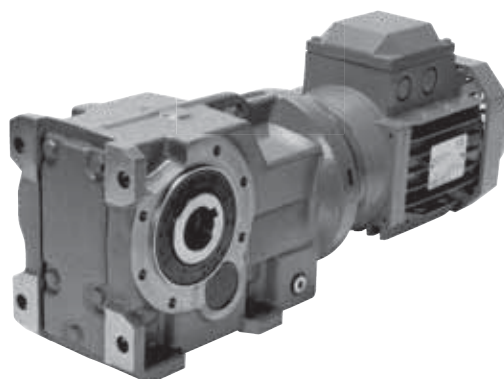
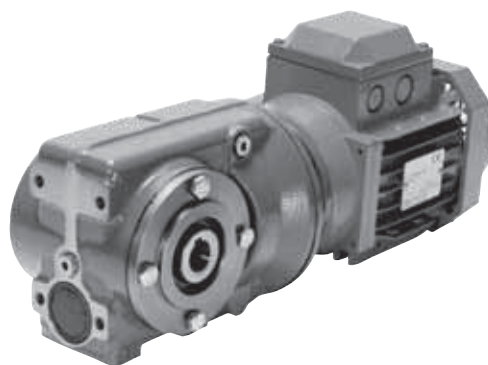
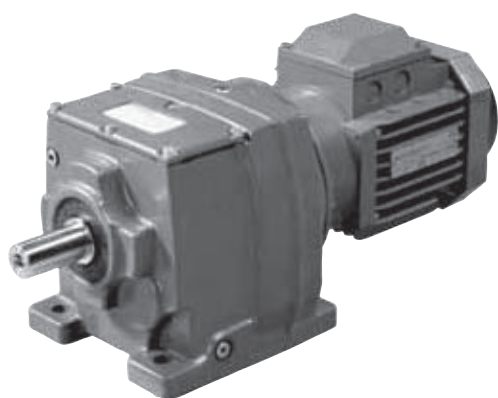

benzlers

with you at every turn

IGM-2.00GB1211

PRODUCTS IN THE RANGE

Serving an entire spectrum of mechanical drive applications from food, energy, mining and metal; to automotive, aerospace and marine propulsion, we are here to make a positive difference to the supply of drive solutions.

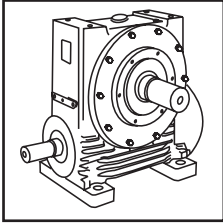

Series A
Worm Gear units
and geared motors
in single & double
reduction types

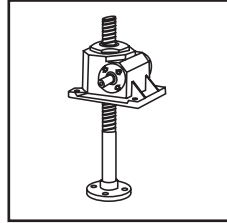

Series BD
Screwjack worm
gear unit

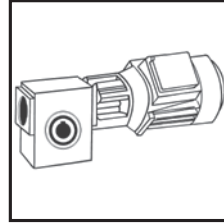

Series BS
Worm gear unit

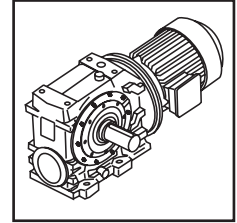

Series C
Right angle drive
helical worm geared
motors & reducers

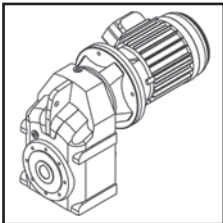

Series F
Parallel angle helical
bevel helical geared
motors & reducers

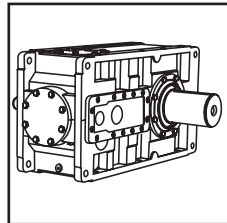

Series G
Helical parallel shaft
& bevel helical right
angle drive gear
units

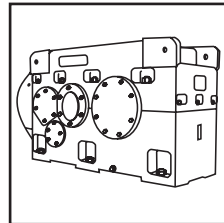

Series H
Large helical parallel
shaft & bevel helical
right angle drive units

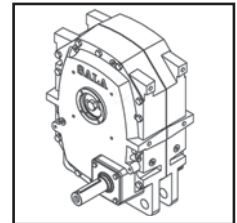

Series J
Shaft mounted
helical speed
reducers

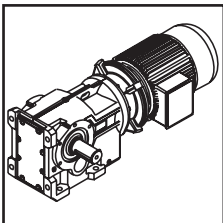

Series K
Right angle helical
bevel helical geared
motors & reducers

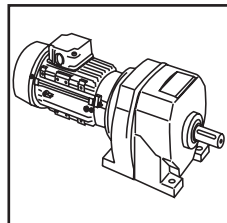

Series M
In-line helical geared
motors & reducers

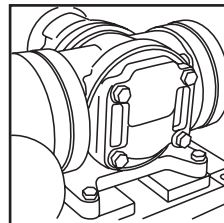

Roloid Gear Pump
Lubrication and fluid
transportation pump

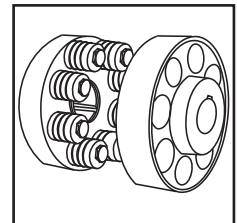

Series X
Cone Ring
Pin and bush
elastomer coupling

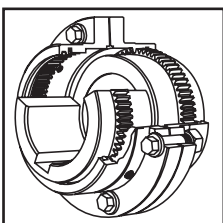

Series X
Gear
Torsionally rigid,
high torque coupling

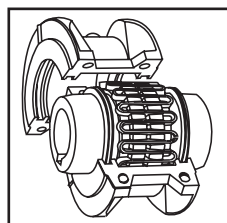

Series X
Grid
Double flexing steel
grid coupling

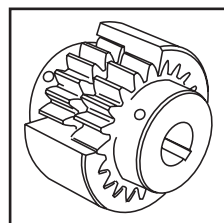

Series X
Nylon
Gear coupling with
nylon sleeve

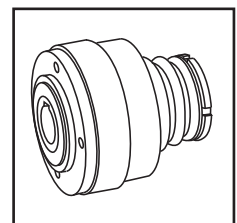

Series X
Torque Limiter
Overload protection
device



We offer a wide range of repair services and many years experience of repairing demanding and highly critical transmissions in numerous industries.

We can create custom engineered transmission solutions of any size and configuration.

Product Safety Information

IMPORTANT

General - The following information is important in ensuring safety. It **must** be brought to the attention of personnel involved in the selection of the equipment, those responsible for the design of the machinery in which it is to be incorporated and those involved in its installation, use and maintenance.

Our equipment will operate safely provided it is selected, installed, used and maintained properly. As with any pumping equipment **proper precautions must be taken** as indicated in the following paragraphs, to ensure safety.

Potential Hazards - these are **not** necessarily listed in any order of severity as the degree of danger varies in individual circumstances. It is important therefore that the list is studied in its entirety:-

- 1) Fire/Explosion
 - (a) Oil mists and vapour are generated within gear units. It is therefore dangerous to use naked lights in the proximity of the pump openings, due to the risk of fire or explosion.
 - (b) In the event of fire or serious overheating (over 300 oC), certain materials (rubber, plastics, etc.) may decompose and produce fumes. Care should be taken to avoid exposure to the fumes, and the remains of burned or overheated plastic/rubber materials should be handled with rubber gloves.
- 2) Guards - Rotating shafts and couplings must be guarded to eliminate the possibility of physical contact or entanglement of clothing. It should be of rigid construction and firmly secured.
- 3) Noise - High speed gearboxes and gearbox driven machinery may produce noise levels which are damaging to the hearing with prolonged exposure. Ear defenders should be provided for personnel in these circumstances. Reference should be made to the Department of Employment Code of Practice for reducing exposure of employed persons to noise.
- 4) Lifting - Where provided (on larger units) only the lifting points or eyebolts must be used for lifting operations (see maintenance manual or general arrangement drawing for lifting point positions). Failure to use the lifting points provided may result in personal injury and/or damage to the product or surrounding equipment. Keep clear of raised equipment.
- 5) Lubricants and Lubrication
 - (a) Prolonged contact with lubricants can be detrimental to the skin. The manufacturer's instruction must be followed when handling lubricants.
 - (b) The lubrication status of the equipment must be checked before commissioning. Read and carry out all instructions on the lubricant plate and in the installation and maintenance literature. Heed all warning tags. Failure to do so could result in mechanical damage and in extreme cases risk of injury to personnel.
- 6) Electrical Equipment - Observe hazard warnings on electrical equipment and isolate power before working on the unit or associated equipment, in order to prevent the machinery being started.
- 7) Installation, Maintenance and Storage
 - (a) In the event that equipment is to be held in storage, for a period exceeding 6 months, prior to installation or commissioning, we must be consulted regarding special preservation requirements. Unless otherwise agreed, equipment must be stored in a building protected from extremes of temperature and humidity to prevent deterioration.
The rotating components (gears and shafts) must be turned a few revolutions once a month (to prevent bearings brinelling).
 - (b) External pump components may be supplied with preservative materials applied, in the form of a "waxed" tape overwrap or wax film preservative. Gloves should be worn when removing these materials. The former can be removed manually, the latter using white spirit as a solvent.
Preservatives applied to the internal parts of the pump do not require removal prior to operation.
 - (c) Installation must be performed in accordance with the manufacturer's instructions and be undertaken by suitably qualified personnel.
 - (d) Before working on the pump or associated equipment, ensure that the load has been removed from the system to eliminate the possibility of any movement of the machinery and isolate power supply. Where necessary, provide mechanical means to ensure the machinery cannot move or rotate. Ensure removal of such devices after work is complete.
 - (e) Ensure the proper maintenance of gearboxes in operation. Use only the correct tools and our approved spare parts for repair and maintenance. Consult the Maintenance Manual before dismantling or performing maintenance work.
- 8) Hot Surfaces and Lubricants
 - (a) During operation, pumps may become sufficiently hot to cause skin burns. Care must be taken to avoid accidental contact.
 - (b) After extended running the pump may reach temperatures sufficient to cause burns. Allow equipment to cool before servicing or performing adjustments.
- 9) Selection and Design
 - (a) Where gear units provide a backstop facility, ensure that back-up systems are provided if failure of the backstop device would endanger personnel or result in damage.
 - (b) The driving and driven equipment must be correctly selected to ensure that the complete machinery installation will perform satisfactorily, avoiding system critical speeds, system torsional vibration, etc.
 - (c) The equipment must not be operated in an environment or at speeds, powers, torques or with external loads beyond those for which it was designed.
 - (d) As improvements in design are being made continually the contents of this catalogue are not to be regarded as binding in detail, and drawings and capacities are subject to alterations without notice.

The above guidance is based on the current state of knowledge and our best assessment of the potential hazards in the operation of the pump.

Any further information or clarification required may be obtained by contacting our Application Engineers.

Section	Description	Page No
-	Declaration of Conformity/Incorporation	1
1	General Information	2
2	External Protection	2
3	Reading the Nameplate	2cs
4	The  Marking	2
5	Installation	3
	5.1 Safety Warning	3
	5.2 Prior to Installation	3
	5.3 Fitting Components to Input or Output Shafts	3
	5.4 Fitting the Motor	4
	5.5 Installing Foot or Flange Mounted Units	4
	5.6 Installing Shaft Mounted Units	5
	5.7 Lifting	5
	5.8 Special Instructions for units in a potentially explosive atmosphere	5
6	Lubrication	6
	6.1 General	6
	6.2 Ventilator	6
	6.3 Oil Level	6
7	Motor Connections	7
8	Starting Up	7
9	Operation	7
	9.1 Noise	7
	9.2 General Safety	7
	9.3 Gear units for use in potentially explosive atmosphere	7
10	Maintenance	8
	10.1 Prior to any maintenance operations	8
	10.2 Oil Plugs & Ventilator	8
	10.3 Lubrication	8
	10.4 Bearings	9
	10.5 Grease Lubrication	9
	10.6 Cleaning	9
	10.7 Motor Replacement	9
11	Fault Diagnosis	10
Appendix		
1	Shaft Alignment	11 - 12
2A	Series C, F & K Standard Hollow Output Bore Details	13 - 15
2B	Series F with TA (Taper release) Bushes	16 - 18
2C	Series K with Shrink Disc	19
2D	Series C, F & K Torque Brackets	20 - 21
3	Three Phase Induction Motor Installation	22
4	Lubrication Information	23 - 33

Safety Warning Symbols



Electrical Hazard

Could result in death or serious injury



Danger (Touch Hazard)

Could result in death or serious injury



Important notes on Explosion Protection



Danger

Could result in serious, slight or minor injuries



Damaging Situation

Could result in damage to gear unit or driven machinery



Cleaning

Periodic cleaning necessary

Declaration of Conformity

Products:

Series C, F, K & M - Gear Units.

Radicon Transmission UK Ltd hereby declares that products listed above have been designed in accordance with the following Directives and Standards.

- The Machinery Directive 2006/42/EC
- EN ISO 12100-1,2 The Safety of Machinery
- Conforms to all other harmonized standards, tests, and specifications, (In as much as they apply to our products)

Declaration of Incorporation

According to Machinery Directive 2006/42/EC Annex IIB

This product must not be put into service until the machinery into which it is to be incorporated has been declared in conformity with the provisions of the machinery directive 2006/42/EC.

The equipment shall only be loaded within the framework of our recommendations, and installed and operated in accordance with our installation and maintenance instructions.

The company hereby draws attention to the dangers of improper use of this equipment and particularly warns users against operating with inadequate guarding of rotating parts and the use of naked lights in close proximity to the equipment.

Radicon Transmission UK Ltd will, upon a reasoned request from national authorities, provide any relevant information on its products.

Signed by:



ENGINEERING MANAGER
Radicon Transmission UK Ltd

radicon 
with you at every turn

Radicon Transmission UK Limited

Unit J3 Lowfields Business Park,
Lowfields Way, Elland, West Yorkshire, HX5 9DA
United Kingdom

Tel: +44 (0)1484 465 800
Fax: +44 (0)1484 465 801
sales@radicon.com
www.radicon.com

Company No 7397993 England

1. General Information

The following instructions will help you achieve a satisfactory installation of your gear unit, ensuring the best possible conditions for a long and trouble free operation.

All units are tested and checked prior to dispatch, a great deal of care is taken in packing and shipping arrangements to ensure that the unit arrives at the customer in the approved condition.

2. External Protection

All Series M C F & K units are provided with protection against normal weather conditions. Where units are to operate in extreme conditions, or where they are to stand for long periods without running, e.g. during plant construction, consult our application engineers so that arrangements for adequate protection can be made.

3. Reading the Nameplate

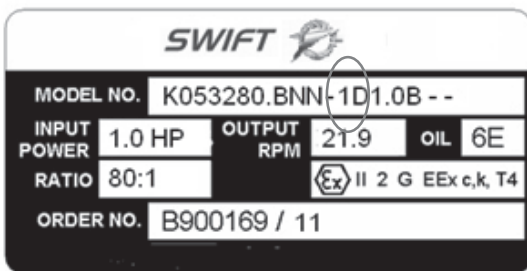

3.1 Unit Identification

When requesting further information, or service support quote the following information from the nameplate:

Unit type (Model No)
Order Number / Year of Manufacture

3.2 Gear Unit Rating

The power rating (HP) speed (rpm) and gear unit ratio are marked on the nameplate – Check that these details match the requirements of the machine prior to installation

3.3 Mounting Position

The mounting position can be determined from character 13 of the Model Number (Circled)
See Appendix 4 for details. The gear unit must only be installed in the specified mounting position

3.4 Lubrication Grade

The lubrication grade is marked on the nameplate. See Appendix 4 for type and quantity of lubricant.

3.5 Group/Category/Temperature Class

Only units specifically selected for use in a potentially explosive atmosphere will be factory engraved with the Ex group, category and temperature class.

4. The Marking

Gear units with  marking are specifically selected for use as a component of an industrial system operating in a potentially explosive atmosphere

Provided the gear unit is correctly selected, Ex marked and installed in accordance with these instructions it will comply with the EU directive 94/9EC (ATEX 100a)

Units may be selected by our application engineers for use only in the following potentially explosive atmospheres: Hazard Group II Cat 2 (zones 1 & 21) or Group II Cat 3 (zones 2 & 22)

Motors, couplings, or any other equipment fitted to the gear unit must also comply with this directive.

If the gear unit is supplied as a geared motor package it is important to check the nameplates of both the gear unit and the motor (or any other equipment fitted) corresponds with the classification of the potentially explosive atmosphere in which the unit is to be installed.

5. Installation

5.1 Safety Warning

<p>WARNING!</p>  <p>CAUTION</p>	<p>The customer shall be responsible for the proper use of articles supplied by the company, particularly rotating shafts between the driving and driven members, and the provision of safety guarding.</p> <p>The company shall not be responsible for any injury or damage sustained as a result of the improper use of the articles supplied.</p> <p>Attention is hereby drawn to the danger of using naked lights in proximity to openings in gearboxes and gear units supplied by the company, and the company shall not be liable for any claim for injury or damage arising from any action in contravention of this warning.</p>
---	--



5.2. Prior to Installation

- 5.2.1. Check gear unit has not been damaged.
- 5.2.2. Check the gear unit / motor nameplate matches the requirements of the machine the unit is to be installed on.
- 5.2.3. Thoroughly clean the shaft and mounting surfaces that are to be used of anti-corrosion agents using a commercially available solvent. Ensure solvent does not make contact with the oil seals.

5.3. Fitting of components to either the unit input or output shaft

- 5.3.1. Ensure shaft extensions, bores & keys etc are cleaned.
- 5.3.2. Shaft diameters below 1.5" are held to limits of + 0.0000" / - 0.0005"
Shaft diameters of 1.5" and above are held to limits of + 0.000" / - 0.001"
- 5.3.3. Items (such as gears, sprockets, couplings etc) should not be hammered onto these shafts since this would damage the shaft support bearings.
- 5.3.4. The item should be pushed onto the shaft using a screw jack device fitted into the threaded hole provided in the end of the shaft
- 5.3.5. Items fitted to shafts may be heated to 177 / 212°F (80 / 100°C) to aid assembly further.



5.4. Fitting the Motor

Follow these instructions only if the product is supplied without motor

5.4.1. Ensure motor bushing (if supplied) is correctly assembled into the gear unit plug-in shaft.



5.4.2. Fit the motor drive key or the special carbon fiber drive key (if supplied)
Note! The carbon fiber drive key may require shortening to suit certain motors.

5.4.3. Spray the plug-in bore with anti-fretting compound (Rocol DFSM or equivalent)

5.4.4. Slide the motor shaft fully into the plug-in bore (do not hammer)



5.4.5. Secure motor flange to the gear unit with the fastenings provided

5.4.6. Torque tighten the bolts to value specified in Section 5.5 -Table 2, (Note! Bolt torques for aluminum flanged motors should be 75% of the values listed in Table 2)

5.5. Foot Mounted or Flange Mounted Units

5.5.1. Ensure the base foundation / flange mounting surface is flat¹, vibration absorbing and torsionally rigid.
(¹ Maximum permissible flatness error for the mounting surface is 0.005")

5.5.2. The gear unit must be installed in the specified mounting position. The maximum deviation from the designated mounting position is ± 5° (unless gear unit is suitably modified and approved for non standard mounting positions).

5.5.3. Align unit (see Appendix 1).

Note: It is important to ensure when aligning unit on a base plate that all machined mounting points are supported over their full area.

If steel packing's are used, these should be placed either side of as close to the foundation bolt as possible.

During final bolting ensure the unit or base plate is not distorted as this would cause strains in the gear case resulting in errors of alignment of shafts and gearing.

Check all mounting points are fully supported and adjust if necessary by using steel packing's.

Torque tighten the bolts to value specified in Table 2 except aluminium flange motors,

Bolt torques for aluminium flanged motors should be 75% of the values listed below.

Secure unit or base plate (if fitted) to a rigid foundation using heavy duty bolts to ISO grade 8.8 (SAE Grade 5.2) minimum.

Bolt Size	Torque	Bolt Size	Torque
M6	10 Nm	1/4" UNF	7.5 lb.ft
M8	25 Nm	5/16" UNF	15 lb.ft
M10	50 Nm	3/8" UNF	27 lb.ft
M12	85 Nm	1/2" UNF	65 lb.ft
M16	200 Nm	5/8" UNF	132 lb.ft
M20	350 Nm	3/4" UNF	230 lb.ft
M24	610 Nm	1" UNF	545 lb.ft
M30	1220 Nm	1-1/8" UNF	685 lb.ft
M36	2150 Nm	1-3/8" UNF	915 lb.ft

Table 2

5.5.4. Recommended fasteners for securing base mounted units ISO Grade 8.8 (SAE Grade 5.2)

M01	M8 x 25L	3/8" UNF x 1.00" L	K03	M10 x 25L	3/8" UNF x 1.00" L	C03	M8 x 20L	5/16" UNF x 0.75" L
M02	M8 x 30L	3/8" UNF x 1.25" L	K04	M10 x 30L	3/8" UNF x 1.25" L	C04	M10 x 30L	3/8" UNF x 1.25" L
M03	M8 x 30L	3/8" UNF x 1.25" L	K05	M12 x 35L	1/2" UNF x 1.38" L	C05	M10 x 30L	3/8" UNF x 1.25" L
M04	M12 x 40L	1/2" UNF x 1.50" L	K06	M12 x 40L	1/2" UNF x 1.50" L	C06	M12 x 40L	1/2" UNF x 1.50" L
M05	M12 x 40L	1/2" UNF x 1.50" L	K07	M16 x 60L	5/8" UNF x 2.00" L	C07	M16 x 60L	5/8" UNF x 2.00" L
M06	M12 x 40L	1/2" UNF x 1.50" L	K08	M20 x 60L	3/4" UNF x 2.50" L	C08	M20 x 65L	3/4" UNF x 2.50" L
M07	M16 x 45L	5/8" UNF x 1.75" L	K09	M24 x 70L	1" UNF x 2.75" L	C09	M24 x 75L	1" UNF x 3.00" L
M08	M16 x 60L	5/8" UNF x 2.25" L	K10	M30 x 80L	1-1/4" UNF x 3.00" L	C10	M24 x 80L	1" UNF x 3.00" L
M09	M20 x 70L	3/4" UNF x 2.75" L	K12	M36 x 100L	1-3/8" UNF x 4.00" L			
M10	M24 x 80L	1" UNF x 3.00" L						
M13	M30 x 90L	1-1/4" UNF x 3.50" L						
M14	M36 x 100L	1-3/8" UNF x 4.00" L						

Table 3



5.6. Installing Shaft Mounted Units

- 5.6.1. The gear unit must be installed in the specified mounting position.
- 5.6.2. Assembly of gear unit on to the machine shaft:
There three assembly methods dependant on the gear unit type:
 - Standard straight bore with keyway. See Appendix 2A.
 - Unit fitted with TA bushes. See Appendix 2B.
 - Unit fitted with shrink disc. See Appendix 2C.
- 5.6.3. Anchor gear unit to a secure point on the structure by means of a torque arm. (See Appendix 2D)

5.7. Lifting



- 5.7.1. Use only the lifting points provided.
- 5.7.2. Series F & K units have a lifting hole in the gear housing as indicated with the arrow.

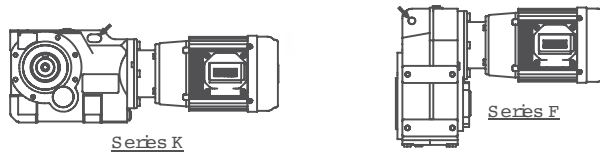

- 5.7.3. Larger Series M & C units are supplied with a lifting eye.

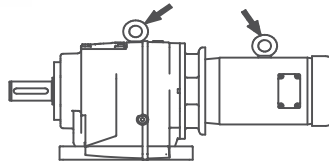

- 5.7.4. If the motor is supplied with a lifting eye, the lifting point on the motor as well as the lifting point on the gear unit should be used.

5.8. Special Instructions for units to be used in a potentially explosive atmosphere



- 5.8.1. If the unit has been damaged in transit do not use. (Remove all transport fixtures and packing's prior to start up)
- 5.8.2. Check nameplate of unit corresponds with the sites potentially explosive atmosphere classification.
- 5.8.3. Check ambient temperature falls within lubricant grade recommendations. (See Approved Lubricants in Appendix 4)
- 5.8.4. Make sure no potentially explosive atmosphere exists during installation.
- 5.8.5. Make sure that gear unit is sufficiently ventilated with no external heat input – cooling air temperature should not exceed 105°F
- 5.8.6. Ensure mounting position corresponds to that marked on the nameplate. (Note! ATEX approval is only valid for the mounting position specified on the nameplate)
- 5.8.7. Check motors, couplings or any other equipment to be fitted to the gear unit has ATEX approval. Check information listed on the nameplates correspond to the environmental conditions of the site.
- 5.8.8. Ensure gearbox is not subjected to any loading greater than those marked on the nameplate.
- 5.8.9. **For units operated with inverter drives**, check motor suitability for use with the inverter. Ensure that the inverter parameters do not exceed those of the motor.
- 5.8.10. **For belt driven units**, check all belts fitted are of sufficient electrical leakage resistance. (< 109 Ω).
- 5.8.11. Ensure the gear unit and other equipment fitted is electrically grounded (Earthed).
- 5.8.12. Check and adjust safety guards and covers so that there is no ignition source from sparks that may be thrown by moving parts making contact with guards etc.
- 5.8.13. Ensure safety guards and covers etc... are designed dust tight or designed to prevent a build up of dust deposits from forming when the unit is used in Zone 21 or Zone 22 classification areas.



6. Lubrication

6.1. General

- 6.1.1. Series M F & K size 7 and below will be supplied factory filled with a quantity of EP mineral oil (Grade 6E) appropriate to the intended mounting position. However if, as requested, the gear unit is supplied without lubricant then the oil quantity required is obtained from Appendix 4.
- 6.1.2. Series M F & K size 8 and larger are supplied without lubricant (unless factory filled by request). Recommended lubricants are listed in our Approved Lubricants pages in Appendix 4.
- 6.1.3. Series C size 6 and below are supplied factory filled with synthetic lubricant (Grade 6G).
- 6.1.4. Series C Size 7 and larger are supplied without lubricant (unless factory filled by request). Recommended lubricants are listed in our Approved Lubricants pages in Appendix 4.

Temperature Limitations

The standard lubricant is suitable for operation in ambient temperatures of 32° to 95 °F (0° to 35°C)
For use outside of these temperatures consult Table L1 (below) or consult our application engineers.

20°F to 68°F (5E) -22°F to 68°F (5G & 5H)	32°F to 95°F	68°F to 120°F
5E ISO CLP(CC) VG 220	6E ISO CLP(CC) VG 320	7E ISO CLP(CC) VG 460
5H ISO CLP(HC) VG 220	5H ISO CLP(HC) VG 220	6H ISO CLP(HC) VG 320
5G ISO CLP(PG) VG 220	6G ISO CLP(PG) VG 320	7G ISO CLP(PG) VG 460

Note! The recommended lubricant for Series **F K & M** is Grade **6E** [CLP(CC)VG320]
The recommended lubricant for Series **C** is Grade **6G** [CLP(PG)VG320]



6.2. Ventilator

- 6.2.1. Clean & secure the ventilator (if supplied) in the correct location for the required mounting position. (See Appendix 4)

6.3. Oil Level:

Units supplied without oil:

- 6.3.1. Fill gear unit with correct type of lubricant until oil escapes from level plug. See Appendix 4

Factory filled units:

- 6.3.2. If the unit is fitted with a level plug, (See Appendix 4) check oil level and top up with correct oil type as necessary.

WARNING Do not overfill as excess may cause overheating and leakage.

- 6.3.3. Re-fit plugs & tighten to correct torque figure – see notes in maintenance section. Clean away any oil spillage from the surface of the gear unit and driven machinery.



7. Motor Connections

To mains:

7.1. Connection of the electric motor to the mains supply should be made by a qualified person. The current rating of the motor will be identified on the motor plate, and correct sizing of the cables to electrical regulations is essential.

Motor terminal connection:

7.2. The motor should be wired in accordance with the manufacturer's instructions.
(General circuit diagrams for 'Own Brand' motors are shown in Appendix 3)

7.3. If an alternative brand motor is supplied, it should always be wired in accordance with the manufacturer's instructions.



8. Starting Up

8.1. Prior to starting up

8.1.1. Ensure the ventilator is fitted (if supplied) see lubrication section 6.2

8.1.2. Check oil level, top up if necessary.

8.1.3. Ensure all safety devices are in place (i.e. guards fitted). Check and adjust guards and covers so that there is no ignition source from sparks that may be thrown by moving parts making contact with guards etc. Ensure coupling guards, covers etc are dust tight or are designed in such a way that a build up of dust deposits cannot form when the unit is used in Zone 21 & Zone 22 classification areas.

8.1.4. Remove any safety devices fitted to prevent machine rotation.

8.1.5. Starting up should only be performed or supervised by suitably qualified personnel.

Caution: Any deviation from normal operating conditions, (increased temperature, noise, vibrations, power consumption etc) suggest a malfunction, inform maintenance personnel immediately.

8.1.6. For units fitted with backstop device, ensure motor is correctly wired for free direction of rotation.

9. Operation

9.1. Noise

The range of product satisfies a noise (sound pressure level) of 85dB(A) or less when measured at 1 meter from the unit surface. Measurements taken in accordance with ISO 8579-1: 1993.

9.2. General Safety

Potential hazards which can be encountered during installation, maintenance and operation of drives is covered in greater detail in the product safety page at the front of this booklet.

Advice is also given on sensible precautions which need to be taken to avoid injury or damage. **PLEASE READ!**

9.3. Gear units for use in a potentially explosive atmosphere

After 3 hours of operation check the gear unit surface temperature. This temperature should not exceed 230°F (110°C) If temperature exceeds this limit, shut down immediately and contact our application engineers.

10. Maintenance



10.1. Prior to any maintenance operations

- 10.1.1. De-energize the drive and secure against unintentional switch on.
- 10.1.2. Wait until the unit has cooled down – Danger of skin burns & pressure build up.



10.2. Oil plugs/ventilator

- 10.2.1. Prior to removing plugs, ensure that the unit has cooled sufficiently so that oil will not burn.
- 10.2.2. Remove ventilator plug prior to removing level and/or drain plug. Warning do not stand over ventilator plug whilst removing as pressure build up behind the valved ventilator may cause it to eject when removed.
- 10.2.3. Place a container under the oil drain plug to be removed. Note: it is recommended that the oil should be slightly warm, (100°- 120°F) when drained. (Cooler oil will be more difficult to drain correctly).



- 10.2.4. Top ups or refills should be done through the ventilator position.
- 10.2.5. Remember to refit all plugs and torque tighten to table M1 below.
- 10.2.6. Clean away any oil spillage.

Plug	Torque
M10	12Nm (8.9 lb.ft)
M12	20Nm (14.7 lb.ft)
M14	26Nm (19.2 lb.ft)
M16	34Nm (25 lb.ft)
M22	65Nm (48 lb.ft)

Table M1



10.3. Lubrication

- 10.3.1. Periodic inspection.

For units fitted with level plug or other level indicating device. Check the oil level every 3000 hours or 6 months (whichever is sooner) and if necessary top up with the recommended type of lubricant.



- 10.3.2. Oil changes.

Smaller size units (without ventilator) are supplied factory filled and lubricated for life except for the following conditions:

- Mineral oil filled units operating at over 160°F surface temperature should be drained and refilled with the correct quantity of oil after 3 years operation.
- All units that are required to work in potentially explosive atmospheres (Group II category 2 zones 1 & 21 or category 3 zones 2 & 22) should be drained and refilled with correct quantity of lubricant in accordance with the schedule as listed in Table M2 - See Appendix 4 for correct oil quantity.

All larger size units (supplied with ventilator) should be drained and refilled with correct quantity of lubricant in accordance with the Tables M2 - See Appendix 4 for correct oil quantity.

Warning.



Do not mix Synthetic and Mineral lubricants.
Do not overfill the unit as this can cause leakage and overheating.



Oil Change Period: Series F K & M

UNIT OPERATING TEMPERATURE	RENEWAL PERIOD	
	MINERAL OIL	SYNTHETIC OIL
<165°F	17000 HOURS OR 3 YEARS	26000 HOURS OR 3 YEARS
175°F	12000 HOURS OR 3 YEARS	26000 HOURS OR 3 YEARS
185°F	8500 HOURS OR 3 YEARS	21000 HOURS OR 3 YEARS
195°F	6000 HOURS OR 2 YEARS	15000 HOURS OR 3 YEARS
205°F	4200 HOURS OR 17 MONTHS	10500 HOURS OR 3 YEARS
215°F	3000 HOURS OR 12 MONTHS	7500 HOURS OR 2 1/2 YEARS
225°F	2100 HOURS OR 8 MONTHS	6200 HOURS OR 2 YEARS
230°F	1500 HOURS OR 6 MONTHS	2100 HOURS OR 18 MONTHS

Oil Change Period: Series C

UNIT OPERATING TEMPERATURE	RENEWAL PERIOD	
	MINERAL OIL	SYNTHETIC OIL
<150°F	17000 HOURS OR 3 YEARS	26000 HOURS OR 3 YEARS
155°F	12000 HOURS OR 3 YEARS	26000 HOURS OR 3 YEARS
165°F	8500 HOURS OR 3 YEARS	22000 HOURS OR 3 YEARS
175°F	6000 HOURS OR 2 YEARS	15000 HOURS OR 3 YEARS
185°F	4200 HOURS OR 17 MONTHS	10500 HOURS OR 3 YEARS
195°F	3000 HOURS OR 12 MONTHS	7500 HOURS OR 2 1/2 YEARS
205°F	2100 HOURS OR 8 MONTHS	6000 HOURS OR 2 YEARS
215°F	1500 HOURS OR 6 MONTHS	4500 HOURS OR 18 MONTHS

Table M2

NB: INITIAL FILL OF OIL SHOULD BE CHANGED IN A NEW GEAR UNIT AFTER 1000 HOURS OPERATION OR ONE YEAR WHICHEVER IS THE SOONEST



10.4. Bearings

10.4.1 For marked units bearings should be checked after 5 years operation, and replaced (if necessary)

10.5. Grease Lubrication

10.5.1. Where re-greasing points are provided add 2 shots monthly of NLGI 2 grade grease. See appendix 4 for details of approved grease.



10.6. Cleaning

10.6.1. With the drive stationary, periodically clean any dirt or dust from the gear unit and the electric motor cooling fins and fan guard to aid cooling.



10.6.2. Ensure any dust build up does not exceed 0.2" maximum

10.7. Motor Replacement



10.7.1. Isolate and secure the driven machine, and disconnect the motor power supply

10.7.2. Remove the motor flange fastenings

10.7.3. Carefully slide the motor away from the gear unit (do not hammer)



10.7.4. Clean the gear unit plug-in bore and the flange surface

10.7.5. Check the replacement motor is the of correct frame size and power rating for the gear unit, and re-fit the motor as described in Section 5.4

10.7.6. Re-connect motor power supply – See Section 7

Connection of the electric motor to the mains supply should be made by a qualified person.

11. Fault diagnosis

11.1. Gear unit problems:

Symptom	Possible Causes	Remedy
Output shaft does not rotate, even though the motor is running or the input shaft is rotating.	Drive between shafts interrupted in the gear unit	Return the gear unit / geared motor for repair
Unusual, regular running noise	a) A meshing or grinding sound : damage to bearings b) A knocking sound : irregularity in the gearing	a) Check oil (See Inspection and Maintenance) b) Contact our Application Engineers
Unusual, irregular running noise	Foreign matter present in the oil	a) Check oil (See Inspection and Maintenance) b) Stop the unit, Contact our Application Engineers
Oil leaking ¹ • from the gear unit cover • from the motor flange • from the gear unit flange • from the output end oilseal	a) Defective gasket on gear unit cover b) Defective gasket c) Gear unit not ventilated	a) Retighten screws on gear unit cover and observe gear unit. If oil still leaks contact our Application Engineers b) Contact our Application Engineers c) Vent the gear unit (see Appendix 4 - Mounting positions)
Oil leaking from the ventilator	a) Gear unit over filled with oil b) Gear unit installed in an incorrect mounting position c) Frequent cold starts (oil foaming) and/or high oil level.	a) Correct the oil level (see lubrication section) b) Fit the ventilator in the correct position (see Appendix 4 Mounting positions) and check oil level (see lubrication) c) Check the oil level (see lubrication)

1) it is normal for small amounts of oil/grease to leak out of the oil seal during the running in period (24 hours running time)

When contacting our sales office

Please have the following information available:

- Nameplate data (complete)
- Type and extent of the problem encountered
- The time and the circumstances the problem occurred
- A possible cause

Any further information or clarification required may be obtained by contacting our sales office, please see contact details at the back of this booklet.

Shaft Alignment.

Errors of alignment fall into categories of angularity (see Figure 1) and eccentricity (see Figure 2), or a combination of both.

Errors of angularity should be checked for, and corrected, before errors of eccentricity.

Alignment in accordance with the following procedure will ensure vibration levels meeting those set out in ISO 10816 Part 1.

Errors of Angularity

If the faces are perfectly true, the angularity can be checked by keeping both shafts stationary and taking measurements with a block gauge and feelers at the four points 1, 2, 3 and 4 as shown in Figure 3. The difference between the readings 1 and 3 will give the error of alignment in the vertical plane, over the length of the shaft equal to the diameter of the coupling flanges, and from this the difference in the relative heights of the feet of the motor or other connected machine can be found by proportion. Similarly, the difference between the reading 2 and 4 gives the amount of sideways adjustment necessary to correct any errors of alignment in the horizontal plane.

Generally, however, the coupling faces will not be absolutely true and whilst any errors so found could be allowed for in checking angularity by the stationary method an easier method presents itself. This consists in marking the points 1 on both "A" and "B" and rotating both half couplings, keeping the marked points together. By taking measurements each quarter-revolution the errors in the vertical and horizontal planes are again found.

NOTE: Check the alignment after running the unit until it has attained its normal working temperature. Any discrepancies can then be rectified.

The permitted angularity error is as follows :

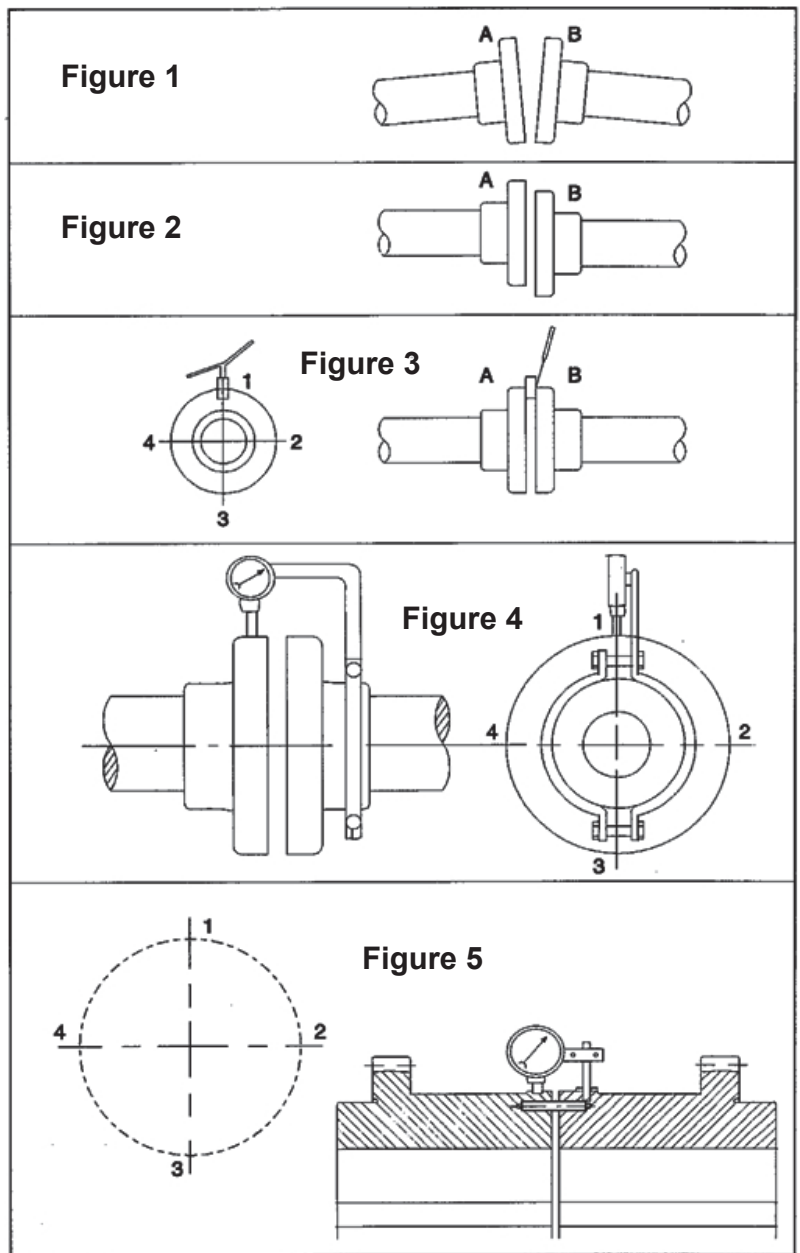

Type of Coupling	Allowable Gap (G)
Rigid Coupling	$G = 0.0005 D$
All other types	Please see appropriate Installation and Maintenance Manual for coupling type fitted

NOTE: D is the diameter (mm) at which the gap is measured.

Errors of Eccentricity

The procedure for measuring eccentricity is precisely analogous to that used for angularity. In this case, however, the measurements are taken in a radial direction and the most convenient and accurate means of doing this utilizes a dial indicator suitably clamped to one half coupling, and bearing on the hub or flange of the other, as shown in figures 4 and 5 on page 11.

Care must however; be taken to ensure the support for the dial indicator is sufficiently rigid to prevent the weight of the indicator from causing deflection and, in consequence, inaccurate readings. Extra care should be taken where taper roller bearings are fitted to ensure that alignment is checked with shafts in mid-point position and a final check made with the unit at operating temperature.

Type of Coupling	Unit Size	Allowable Eccentricity
Rigid	SIZE 08 & UNDER	0.001"
	SIZE 09 & OVER	0.001"
All Other types	Please see appropriate installation and maintenance manual for coupling type fitted	

SPECIAL NOTE CONCERNING RIGID COUPLINGS

In lining up elements involving rigid couplings it is important that no attempt is made to correct errors of alignment or eccentricity greater than those above by tightening of the coupling bolts (This applies when the system is cold or at operating temperature). The result is miss-alignment and the setting up of undue stresses in the shaft, coupling and bearings. This will be revealed by the springing apart of the coupling faces if the bolts are slackened off. A check on the angularity of a pre-assembled job, after bolting down, can be obtained in the case of rigid couplings by slackening off the coupling bolts, when any misalignment will cause the coupling faces to spring apart. This check may not, however, reveal any strains due to eccentricity owing to the constant restraint imposed by the spigot.

SERIES X COUPLINGS

We produce standard flexible couplings to cover the complete range of gear units, please contact Application Engineering for details.

Shaft Mounted Units - Standard Bore/Shaft Assembly

Customers Shaft Details

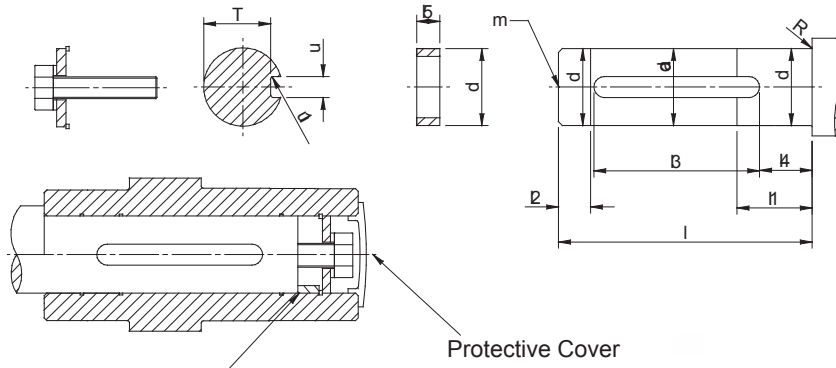

Spacer - only used when shaft has no shoulder

UNIT	Bore	d	da	l	l1	l2	l3	l4	l5	m	N	R	T	u	u1
C03	Inch	0.7497" 0.7492"	0.73"	3.73"	1.18"	0.40"	2.75"	0.13"	0.87"	1/4" UNF	6 lb.ft	0.03"	0.644" 0.638"	0.188" 0.187"	0.01"
C04	Inch	1.2486" 1.2480"	1.23"	3.90"	1.77"	0.60"	3.13"	0.13"	1.02"	3/8" UNF	12 lb.ft	0.03"	1.11" 1.10"	0.252" 0.250"	0.01"
C05	Inch	1.3746" 1.3740"	1.36"	4.09"	2.09"	0.71"	3.50"	0.13"	0.91"	1/2" UNF	15 lb.ft	0.03"	1.20" 1.19"	0.312" 0.311"	0.01"
C06	Inch	1.4996" 1.4990"	1.48"	4.92"	2.68"	0.91"	4.00"	0.13"	1.22"	5/8" UNF	35 lb.ft	0.03"	1.29" 1.28"	0.377" 0.375"	0.01"
C07	Inch	1.9996" 1.9990"	1.98"	6.02"	3.53"	1.18"	5.63"	0.13"	1.50"	5/8" UNF	35 lb.ft	0.03"	1.72" 1.71"	0.502" 0.500"	0.02"
C08	Inch	2.3746" 2.3739"	2.35"	7.20"	4.13"	1.38"	6.88"	0.13"	1.46"	3/4" UNF	60 lb.ft	0.03"	2.02" 2.01"	0.627" 0.625"	0.02"
C09	Inch	2.7496" 2.7489"	2.73"	8.94"	5.31"	1.77"	8.63"	0.13"	1.28"	3/4" UNF	60 lb.ft	0.03"	2.40" 2.39"	0.627" 0.625"	0.02"
C10	Inch	3.2495" 3.2486"	3.23"	12.81"	5.91"	1.77"	12.0"	0.40"	1.81"	3/4" UNF	60 lb.ft	0.03"	2.83" 2.82"	0.752" 0.750"	0.02"
F02	Inch	0.9996" 0.9990"	0.98"	3.23"	1.57"	0.51"	3.00"	0.12"	0.91"	3/8" UNF	12 lb.ft	0.03"	0.859" 0.853"	0.252" 0.250"	0.01"
F03 & K03	Inch	1.2496" 1.2490"	1.23"	3.23"	1.77"	0.59"	3.00"	0.12"	0.91"	3/8" UNF	12 lb.ft	0.03"	1.11" 1.10"	0.252" 0.250"	0.01"
F04 & K04	Inch	1.3746" 1.3740"	1.36"	4.29"	2.36"	0.79"	3.56"	0.12"	0.91"	1/2" UNF	15 lb.ft	0.03"	1.20" 1.19"	0.3145" 0.3125"	0.01"
F05 & K05	Inch	1.4996" 1.4990"	1.48"	4.41"	2.36"	0.79"	3.63"	0.12"	1.18"	5/8" UNF	35 lb.ft	0.03"	1.29" 1.28"	0.377" 0.375"	0.01"
F06 & K06	Inch	1.4996" 1.4990"	1.48"	4.96"	2.95"	0.98"	4.00"	0.12"	1.18"	5/8" UNF	35 lb.ft	0.03"	1.29" 1.28"	0.377" 0.375"	0.01"
F07 & K07	Inch	1.9996" 1.9990"	1.98"	6.02"	3.54"	1.18"	5.00"	0.12"	1.18"	5/8" UNF	35 lb.ft	0.03"	1.72" 1.71"	0.502" 0.500"	0.02"
F08 & K08	Inch	2.3746" 2.3739"	2.36"	6.81"	3.54"	1.18"	5.00"	0.12"	1.45"	3/4" UNF	60 lb.ft	0.03"	2.02" 2.01"	0.627" 0.625"	0.02"
F09 & K09	Inch	2.7496" 2.7489"	2.73"	9.13"	4.13"	1.38"	5.35"	0.12"	1.50"	3/4" UNF	60 lb.ft	0.03"	2.40" 2.39"	0.627" 0.625"	0.02"
F10 & K10	Inch	3.2495" 3.2486"	3.23"	10.83"	4.72"	1.57"	6.75"	0.20"	1.45"	3/4" UNF	60 lb.ft	0.03"	2.83" 2.82"	0.752" 0.750"	0.02"
K12	Inch	3.9995" 3.9986"	3.98"	12.81"	4.72"	1.97"	7.50"	0.40"	1.81"	1" UNF	160 lb.ft	0.03"	3.42" 3.41"	1.002" 1.000"	0.02"

See next page for shaft assembly instructions.



Standard Bore/Shaft Assembly Instructions

1. Spray the hollow shaft bore and mating diameter of output shaft with an anti-fret compound.
2. Fit the shaft to hollow bore location key in position in the output shaft.
3. Fit the circlip into the output sleeve.
4. Fit the output shaft into the output sleeve. Remember to fit a spacer tube (not supplied) if the output shaft has no shoulder. (see dimension table for details)
5. Secure in place with the washer and bolt, Torque tighten the bolt to the values stated in column N in the dimension table.
6. Fit the protective cover over the open end of the output sleeve.

Alternative shaft fixing methods shown below may be considered

Alternative Shaft Fixing Methods

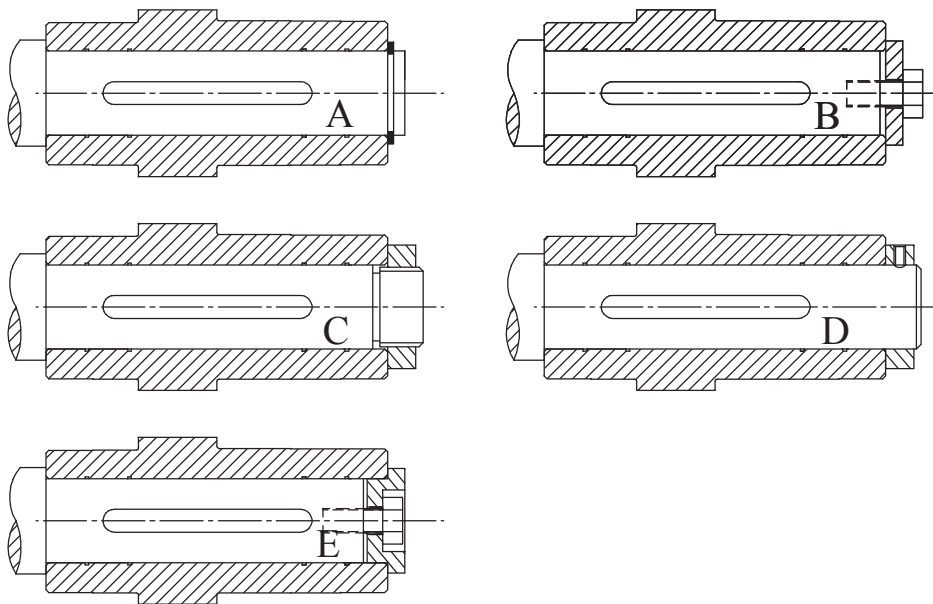

A - Retained with a Circlip

B – Retained with a Plate and Bolt

C – Retained with a Locknut

D – Retained with a Collar and Grub screw

E – Retained with a Plate and Bolt

Standard Bore/Shaft Disassembly.

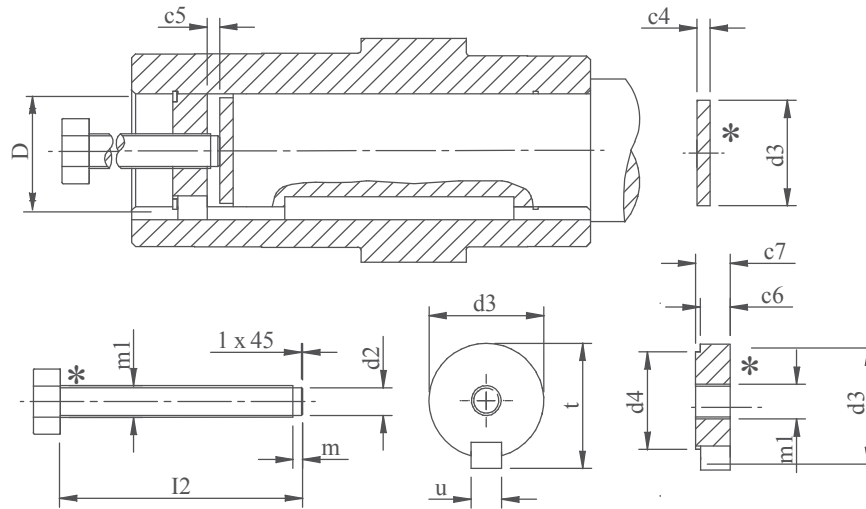

*Parts supplied by customer

UNIT	Bore	c4	c6	c7	D (H7)	d2	d3	d4	l2	m	m1	t	u
C03	Inch	0.20"	0.40"	0.50"	0.750"	0.30"	0.745"	0.45"	4.75"	0.12"	3/8" UNF	0.63"	0.187"
C04	Inch	0.20"	0.60"	0.65"	1.250"	0.50"	1.245"	0.88"	6.50"	0.12"	5/8" UNF	1.10"	0.250"
C05	Inch	0.20"	0.60"	0.65"	1.375"	0.50"	1.370"	1.00"	6.50"	0.12"	5/8" UNF	1.19"	0.312"
C06	Inch	0.20"	0.80"	0.90"	1.500"	0.85"	1.495"	1.13"	8.75"	0.12"	1" UNF	1.28"	0.375"
C07	Inch	0.31"	0.80"	0.90"	2.000"	1.05"	1.995"	1.59"	10.00"	0.20"	1" UNF	1.71"	0.500"
C08	Inch	0.31"	1.00"	1.10"	2.375"	1.05"	2.370"	1.90"	12.25"	0.20"	1-1/4" UNF	2.01"	0.625"
C09	Inch	0.31"	1.00"	1.10"	2.750"	1.05"	2.745"	2.18"	14.50"	0.20"	1-1/4" UNF	2.39"	0.625"
C10	Inch	0.31"	1.00"	1.10"	3.250"	1.05"	3.245"	2.65"	17.00"	0.20"	1-1/4" UNF	2.82"	0.700"
F02	Inch	0.20"	0.60"	0.65"	1.000"	0.38"	0.995"	0.65"	5.00"	0.12"	1/2" UNF	1.09"	0.250"
F03 & K03	Inch	0.20"	0.60"	0.65"	1.250"	0.50"	1.245"	0.88"	6.00"	0.12"	5/8" UNF	1.35"	0.250"
F04 & K04	Inch	0.20"	0.60"	0.65"	1.375"	0.50"	1.370"	1.00"	6.00"	0.12"	5/8" UNF	1.50"	0.312"
F05 & K05	Inch	0.20"	0.80"	0.90"	1.500"	0.85"	1.495"	1.13"	7.00"	0.20"	1" UNF	1.65"	0.375"
F06 & K06	Inch	0.20"	0.80"	0.90"	1.500"	0.85"	1.495"	1.13"	7.00"	0.20"	1" UNF	1.65"	0.375"
F07 & K07	Inch	0.20"	0.80"	0.90"	2.000"	1.05"	1.995"	1.59"	8.50"	0.20"	1" UNF	2.20"	0.500"
F08 & K08	Inch	0.31"	1.00"	1.10"	2.375"	1.05"	2.370"	1.90"	10.00"	0.20"	1-1/4" UNF	2.63"	0.625"
F09 & K09	Inch	0.31"	1.00"	1.10"	2.750"	1.05"	2.745"	2.18"	12.25"	0.20"	1-1/4" UNF	3.01"	0.625"
F10 & K10	Inch	0.31"	1.00"	1.10"	3.250"	1.05"	3.245"	2.65"	14.50"	0.20"	1-1/4" UNF	3.57"	0.700"
K12	Inch	0.31"	1.20"	1.30"	4.000"	1.23"	3.995"	3.15"	16.50"	0.20"	1-1/2" UNF	4.42"	1.000"

Disassembly Procedure

1. Remove locating bolt, retaining plate and circlip
2. Place plate on shaft end to protect the shaft screw thread
3. Assemble disassembly tooling as shown in diagram above
4. Turn screw to apply pressure to shaft end

Series F - With TA (Taper Release) Bushes

The Series F TA Bush option requires a gear unit with a TA type tapered output bore, together with a TA bushing kit comprising of: bush, locking nut, and shaft key/s.



Assembly

1. Thoroughly clean and degrease the machine shaft, bushing and gear unit tapered bore.
NOTE! The bushing nut threads have been coated with an anti-seize compound at the factory, this compound should not be removed.
 Before re-installing a previously used nut, re-coat the nut threads only with an anti-seize compound.
 In extremely severe or corrosive environments, additional anti-seize compound should be applied to the threads of the bushing nut.

2. **THIN WALL BUSHING** (with keyway slot through the bushing wall)
 With the driven shaft keyway at the 12 o'clock position, slide bushing assembly onto the driven shaft, nut end first, and position the keyway slot over the shaft keyway (the bushing may have to be pried open slightly). Insert the drive key (supplied with the bushing) into the shaft.

THICK WALL BUSHING (with separate internal and external keyways)
 Insert the driven shaft key into the driven shaft keyway. If the driven shaft has an open-ended keyway, stake the keyway to prevent axial dislocation of the shaft key under operating conditions. Slide the bushing assembly onto the driven shaft (the bushing may have to be pried open slightly). Rotate the shaft so the external keyway in the bushing is at the 12 o'clock position. Then insert the drive key (supplied with the bushing) into the keyway.

3. Lift the gear unit into position and slide onto the driven shaft taking care that the driven shaft key seats into the gear unit shaft keyway. Do not hammer or use excessive force. Hand tighten the nut (ensure the gear unit is in correct axial location) Lock the driven shaft and tighten the nut using a C spanner or pipe wrench, tighten to torque listed in the table below. Do not over tighten; secure the nut by locking with grub screw.
 Alternate Method (only use if torque cannot be measured) Use wrench to tighten bushing nut until the gear unit cannot be moved axially along the driven shaft by hand, loosen off the bushing nut but do not dislodge the unit from the taper. Re tighten the nut by hand, lock the driven shaft and tighten the nut using a C spanner or pipe wrench, tighten the nut as described in the table below, secure the nut by locking with the grub screw.

4. **VERTICAL APPLICATION** - If the gear unit is mounted vertically below the driven machine a shouldered machine shaft together with a thrust plate and fastener should be used. After securing bushing nut fit thrust plate and tighten fastener to torque listed in the table below.

5. Fit the protective cover.

Disassembly

Caution the gear unit must be supported during the removal process

- A. Remove the protective cover, fixing bolt and end plate (if fitted)
- B. Loosen grub screw on bushing nut.
- C. Fully disengage the bushing nut from the gear unit shaft.
- D. Slide unit away from bushing assembly,
- E. If required remove bushing assembly from shaft,

Bushing Nut Tightening Information

Bushing Size	C Spanner Size	Bushing Nut Tightening Torque lb.in	Number of Turns (only use if torque cannot be measured)
F04(107)TR	2" - 4.75"	1000	1/4 Turn of Nut
F05(107)TR	2" - 4.75"	1000	
F06(115)TR	2" - 4.75"	1000	
F07(203)TR	2" - 4.75"	2000	1/2 Turn of Nut
F08(207)TR	4.5" - 6.25"	2000	
F09(215)TR	4.5" - 6.25"	3000	
F10(317)TR	4.5" - 6.25"	3000	

Retaining Plate

Bushing Size	Fastener Size	Torque lb.in
F04(107)TR	1/2" UNC	1100
F05(107)TR	1/2" UNC	1100
F06(115)TR	1/2" UNC	1100
F07(203)TR	5/8" UNC	2190
F08(207)TR	5/8" UNC	2190
F09(215)TR	7/8" UNC	6400
F10(317)TR	1" UNC	9500

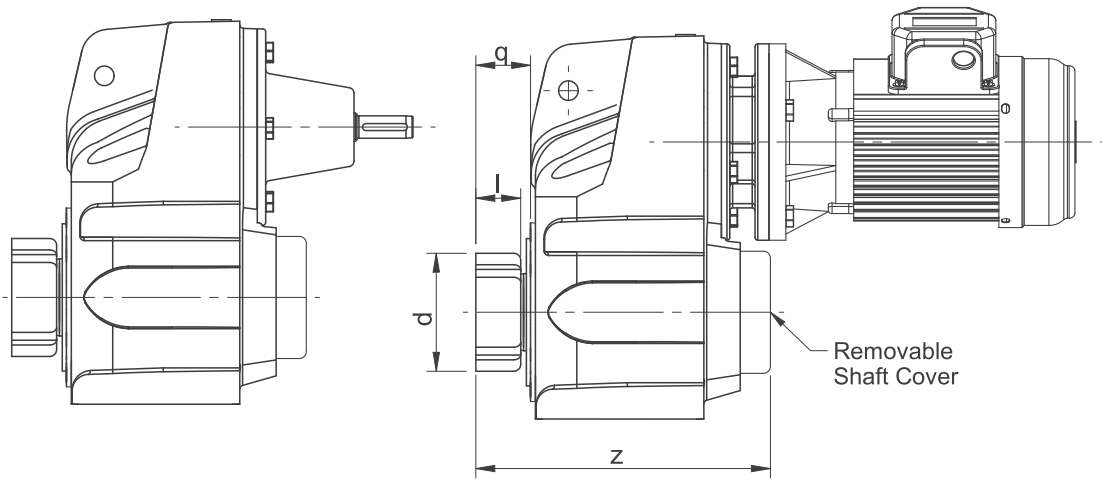

DRIVEN SHAFT

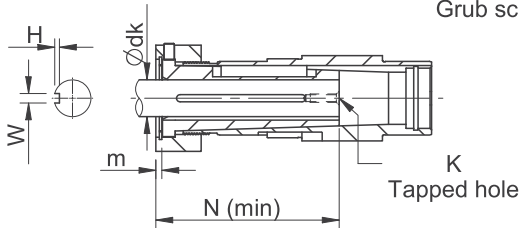

THIN WALLED

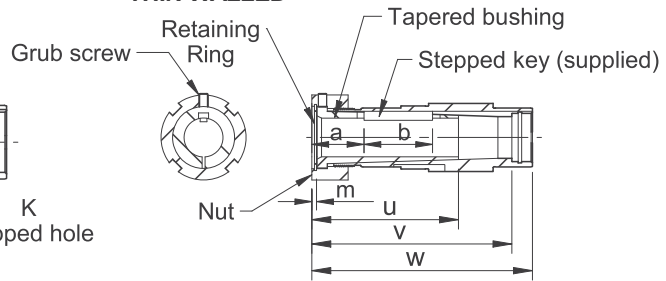

END PLATE
(not supplied)

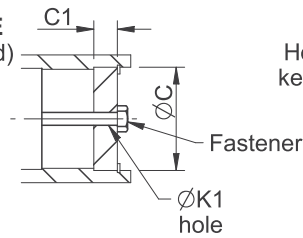

THICK WALLED

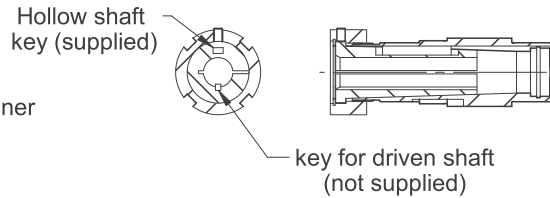

Dimensions (Inches) - See table on next page for bushing dimensions

SIZE	Key		Bush	Hollow Shaft			Nut			Gear Unit	
	a	b	u	v	w	d	l	m	q	z	
F04 (107)TR	1.9	2.5	5	7.15	7.85	3.31	1.26	0.27	1.89	9.2	
F05 (107)TR	1.9	2.5	5	7.09	8.74	3.31	1.26	0.27	1.89	10.4	
F06 (115)TR	2.1	2.75	5.55	7.89	9.9	4.06	1.46	0.3	2.06	11.5	
F07 (203)TR	1.55	3.25	5.55	8.73	10.88	4.31	1.46	0.3	1.97	12.5	
F08 (207)TR	1.24	4.25	6.52	10.18	12.53	4.81	1.46	0.3	2.03	14.6	
F09 (215)TR	2.09	3.5	7.08	13	15	5.68	1.76	0.38	2.24	17.6	
F10 (307)TR	1.59	5	7.39	14.38	16.75	6.06	1.76	0.38	2.41	19.3	

Dimensions (Inches)

SIZE	Driven shaft diameter * (Ødk)	bushing style	driven shaft keyway			driven shaft			end plate			circlip	bushing weight (lbs)
			width (W)	depth (H)	min length ** (b1)	a1	K	N (min)	ØC	C1	K1		
F04 (107)TR & F05 (107)TR	1.000 / 0.996	Thick	1/4	1/8	2.75	-	1/2 UNC	5	1.64	0.3	5/8 UNC	N1300-0162	2.1
	1.125 / 1.121	Thick	1/4	1/8	2.75	-	1/2 UNC	5	1.64	0.3	5/8 UNC	N1300-0162	1.8
	1.188 / 1.184	Thick	1/4	1/8	2.75	-	1/2 UNC	5	1.64	0.3	5/8 UNC	N1300-0162	1.6
	1.250 / 1.246	Thin	1/4	1/8	2.5	1.89	1/2 UNC	5	1.64	0.3	5/8 UNC	N1300-0162	1.5
	1.438 / 1.434	Thin	3/8	3/16	2.5	1.89	1/2 UNC	5	1.64	0.3	5/8 UNC	N1300-0162	1
F06 (115)TR	1.188 / 1/184	Thick	1/4	1/8	2.75	-	1/2 UNC	5.55	2.25	0.37	5/8 UNC	N1300-0225	4.3
	1.250 / 1.246	Thick	1/4	1/8	2.75	-	1/2 UNC	5.55	2.25	0.37	5/8 UNC	N1300-0225	4.1
	1.438 / 1.434	Thick	3/8	3/16	2.5	-	1/2 UNC	5.55	2.25	0.37	5/8 UNC	N1300-0225	3.5
	1.500 / 1.496	Thick	3/8	3/16	2.5	-	1/2 UNC	5.55	2.25	0.37	5/8 UNC	N1300-0225	3.3
	1.625 / 1.620	Thin	3/8	3/16	2.75	2.1	1/2 UNC	5.55	2.25	0.37	5/8 UNC	N1300-0225	2.9
	1.688 / 1.683	Thin	3/8	3/16	2.75	2.1	1/2 UNC	5.55	2.25	0.37	5/8 UNC	N1300-0225	2.7
	1.750 / 1.745	Thin	3/8	3/16	2.75	2.1	1/2 UNC	5.55	2.25	0.37	5/8 UNC	N1300-0225	2.4
	1.938 / 1.933	Thin	1/2	1/4	2.75	2.1	1/2 UNC	5.55	2.25	0.37	5/8 UNC	N1300-0225	1.7
	1.438 / 1.434	Thick	3/8	3/16	2.75	-	5/8 UNC	5.55	2.43	0.43	3/4 UNC	N1300-0244	5
F07 (203)TR	1.500 / 1.496	Thick	3/8	3/16	2.75	-	5/8 UNC	5.55	2.43	0.43	3/4 UNC	N1300-0244	5.1
	1.625 / 1.620	Thick	3/8	3/16	2.75	-	5/8 UNC	5.55	2.43	0.43	3/4 UNC	N1300-0244	4.6
	1.688 / 1/683	Thick	3/8	3/16	2.75	-	5/8 UNC	5.55	2.43	0.43	3/4 UNC	N1300-0244	4.4
	1.750 / 1.745	Thick	3/8	3/16	2.75	-	5/8 UNC	5.55	2.43	0.43	3/4 UNC	N1300-0244	4.4
	1.875 / 1.870	Thin	1/2	1/4	3.25	1.56	5/8 UNC	5.55	2.43	0.43	3/4 UNC	N1300-0244	3.6
	1.938 / 1.933	Thin	1/2	1/4	3.25	1.56	5/8 UNC	5.55	2.43	0.43	3/4 UNC	N1300-0244	3.3
	2.000 / 1.995	Thin	1/2	1/4	3.25	1.56	5/8 UNC	5.55	2.43	0.43	3/4 UNC	N1300-0244	3
	2.188 / 2.183	Thin	1/2	1/4	3.25	1.56	5/8 UNC	5.55	2.43	0.43	3/4 UNC	N1300-0244	3
	1.375 / 1.371	Thick	3/16	5/32	4.75	-	5/8 UNC	6.11	2.83	0.43	3/4 UNC	N1300-0281	7.6
F08 (207)TR	1.438 / 1.434	Thick	3/8	3/16	3.25	-	5/8 UNC	6.11	2.83	0.43	3/4 UNC	N1300-0281	7.3
	1.500 / 1.496	Thick	3/8	3/16	3.25	-	5/8 UNC	6.11	2.83	0.43	3/4 UNC	N1300-0281	7.1
	1.625 / 1.620	Thick	3/8	3/16	3.25	-	5/8 UNC	6.11	2.83	0.43	3/4 UNC	N1300-0281	6.7
	1.688 / 1/683	Thick	3/8	3/16	3.25	-	5/8 UNC	6.11	2.83	0.43	3/4 UNC	N1300-0281	6.4
	1.750 / 1.745	Thick	3/8	3/16	3.25	-	5/8 UNC	6.11	2.83	0.43	3/4 UNC	N1300-0281	6.1
	1.875 / 1.870	Thick	1/2	1/4	3.25	-	5/8 UNC	6.11	2.83	0.43	3/4 UNC	N1300-0281	5.6
	1.938 / 1.933	Thin	1/2	1/4	4.25	1.24	5/8 UNC	6.11	2.83	0.43	3/4 UNC	N1300-0281	5.3
	2.000 / 1.995	Thin	1/2	1/4	4.25	1.24	5/8 UNC	6.11	2.83	0.43	3/4 UNC	N1300-0281	5
	2.188 / 2.183	Thin	1/2	1/4	4.25	1.24	5/8 UNC	6.11	2.83	0.43	3/4 UNC	N1300-0281	4.4
	2.250 / 2.245	Thin	1/2	1/4	4.25	1.24	5/8 UNC	6.11	2.83	0.43	3/4 UNC	N1300-0281	3.7
	2.438 / 2.433	Thin	5/8	5/16	4.25	1.24	5/8 UNC	6.11	2.83	0.43	3/4 UNC	N1300-0281	2.6
	F09 (215)TR	1.938 / 1.933	Thick	1/2	1/4	5.25	-	7/8 UNC	7.08	3.33	0.50	1 UNC	N1300-0334
2.000 / 1.995		Thick	1/2	1/4	5.25	-	7/8 UNC	7.08	3.33	0.50	1 UNC	N1300-0334	11.1
2.188 / 2.183		Thick	1/2	1/4	5.25	-	7/8 UNC	7.08	3.33	0.50	1 UNC	N1300-0334	9.9
2.250 / 2.245		Thick	1/2	1/4	5.25	-	7/8 UNC	7.08	3.33	0.50	1 UNC	N1300-0334	9.5
2.438 / 2.433		Thin	5/8	5/16	3.50	2.09	7/8 UNC	7.08	3.33	0.50	1 UNC	N1300-0334	8.3
2.500 / 2.495		Thin	5/8	5/16	3.50	2.09	7/8 UNC	7.08	3.33	0.50	1 UNC	N1300-0334	7.8
2.688 / 2.682		Thin	5/8	5/16	3.50	2.09	7/8 UNC	7.08	3.33	0.50	1 UNC	N1300-0334	6.5
2.938 / 2.932		Thin	3/4	3/8	3.50	2.09	7/8 UNC	7.08	3.33	0.50	1 UNC	N1300-0334	4.5
F10 (307)TR	2.000 / 1.995	Thick	1/2	1/4	5.25	-	1 UNC	7.39	3.74	0.56	1 1/8 UNC	N1300-0375	17.8
	2.188 / 2.183	Thick	1/2	1/4	5.25	-	1 UNC	7.39	3.74	0.56	1 1/8 UNC	N1300-0375	16.6
	2.250 / 2.245	Thick	1/2	1/4	5.25	-	1 UNC	7.39	3.74	0.56	1 1/8 UNC	N1300-0375	16.2
	2.438 / 2.433	Thick	5/8	5/16	5.25	-	1 UNC	7.39	3.74	0.56	1 1/8 UNC	N1300-0375	14.9
	2.500 / 2.495	Thick	5/8	5/16	5.25	-	1 UNC	7.39	3.74	0.56	1 1/8 UNC	N1300-0375	14.4
	2.688 / 2.682	Thin	5/8	5/16	5.00	1.59	1 UNC	7.39	3.74	0.56	1 1/8 UNC	N1300-0375	13.0
	2.938 / 2.932	Thin	3/4	3/8	5.00	1.59	1 UNC	7.39	3.74	0.56	1 1/8 UNC	N1300-0375	10.9
	3.000 / 2.994	Thin	3/4	3/8	5.00	1.59	1 UNC	7.39	3.74	0.56	1 1/8 UNC	N1300-0375	10.3
	3.188 / 3.182	Thin	3/4	3/8	5.00	1.59	1 UNC	7.39	3.74	0.56	1 1/8 UNC	N1300-0375	8.6
3.438 / 3.432	Thin	7/8	7/16	5.00	1.59	1 UNC	7.39	3.74	0.56	1 1/8 UNC	N1300-0375	6.1	

Series K - With Shrink Disc

The Shrink Disc option requires a gear unit with a Shrink Disc type output bore, together with a Shrink Disc (A) locking device.

The Shrink Disc is a friction device (without keys) which exerts an external clamping force on the hollow gearbox shaft resulting in a mechanical shrink fit of the gear unit and driven shaft.

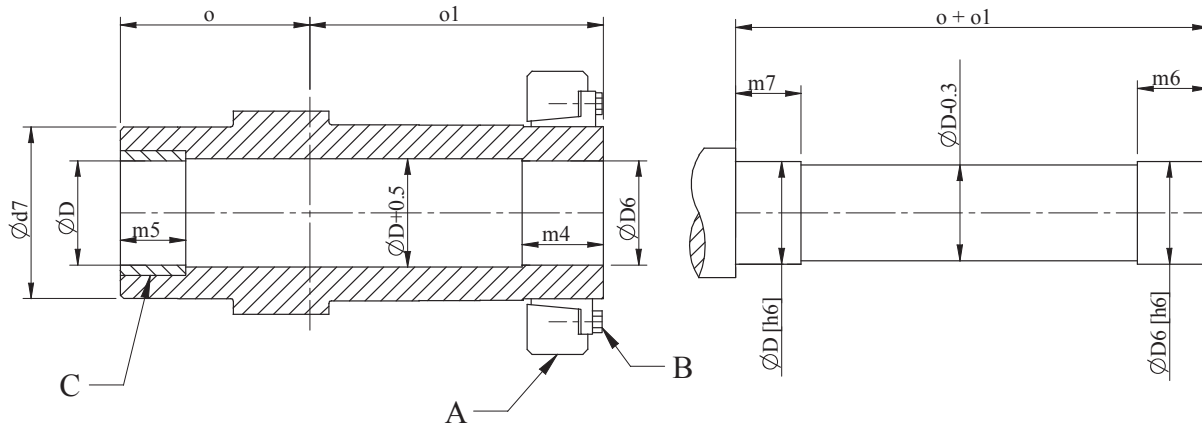

Dimensions (Inches)

SIZE	D	D6	d7	m4	m5	m6	m7	o	o1	Torque Ta (lb.in)
K03	1.181	1.181	1.97	1.22	0.79	1.42	0.98	2.36	3.39	21
K04	1.378	1.378	2.17	1.26	0.79	1.46	0.98	2.95	4.02	21
K05	1.575	1.575	2.36	1.42	0.79	1.61	0.98	3.27	4.41	21
K06	1.575	1.575	2.76	1.50	0.79	1.69	0.98	3.54	4.65	21
K07	1.969	1.969	3.15	1.42	1.18	1.61	1.38	4.13	5.35	26
K08	2.559	2.559	3.54	1.61	1.57	1.81	1.77	4.72	6.34	43
K09	2.953	2.953	3.94	2.17	1.57	2.36	2.17	5.91	7.68	43
K10	3.740	3.740	4.72	2.56	2.36	2.76	2.56	6.89	9.06	74
K12	4.134	4.134	5.51	3.35	2.36	3.54	2.95	8.07	11.02	118



Assembly

1. Clean and degrease the locating diameters of the gear unit hollow shaft bore, the driven shaft and the shrink disk locating surfaces
2. Ensure the Anti-fret yellow metal bush(C) is correctly inserted in the non driving end of the gear unit hollow shaft
3. Draw the gear unit onto the driven shaft.
4. Check and re-apply if necessary molykote 321R (or similar) to the tapered surfaces of the Shrink Disc inner ring and locking collar.
5. Fit the Shrink Disc inner ring and collar into position on the shaft, fit and tighten all the locking screws gradually in succession, do **not** tighten in a diametrically opposite sequence. This tightening sequence will require several passes until all the screws are tightened to the torque specified in the table above.
6. Fit the protective cover.

Disassembly similar to the reverse of the assembly procedure.

- A. Remove any rust and dirt from the assembly
- B. Loosen off the locking screws in succession but do not completely remove.
- C. Remove the shrink disk and withdraw the gear unit from the driven shaft.

NOTE: If the Shrink Disc is to be re-used it should be dismantled and cleaned thoroughly and Molykote 321R (or similar) applied to the tapered surfaces of the inner ring and collar

Series C Torque Bracket

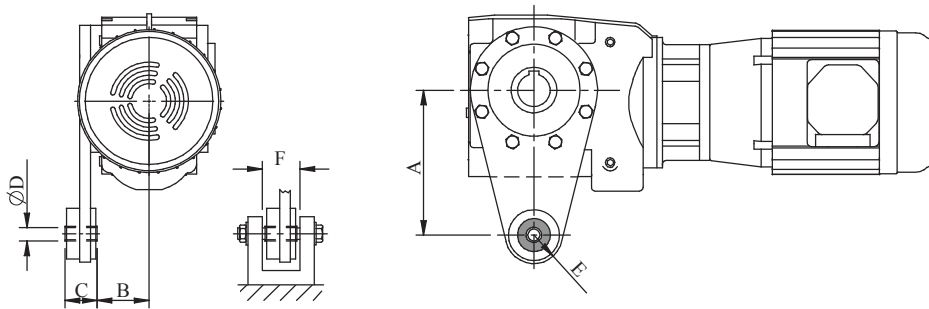

1. It is recommended that the torque bracket is positioned on the side of the gear unit adjacent to the driven machine.
2. The torque bracket requires a clevis type anchoring as shown above (not supplied)
3. The clevis position should be carefully adjusted at assembly so that it does not exert any external radial or axial pressure on the torque bracket

Torque Bracket Dimensions (inches)

Unit	A	B	C	D	E	F (min)
C03	4.33	1.85	1.42	0.41	0.91	1.61
C04	5.12	2.05	1.42	0.41	0.91	1.61
C05	6.30	2.05	1.42	0.41	0.91	1.61
C06	7.87	2.83	1.73	0.65	1.69	1.93
C07	9.84	3.07	2.36	0.65	1.69	2.56
C08	12.20	3.39	2.36	0.65	1.77	2.56
C09	14.96	3.86	3.15	0.98	1.97	3.35
C10	16.93	5.39	3.15	0.98	1.97	3.35

Series F Torque Buffers

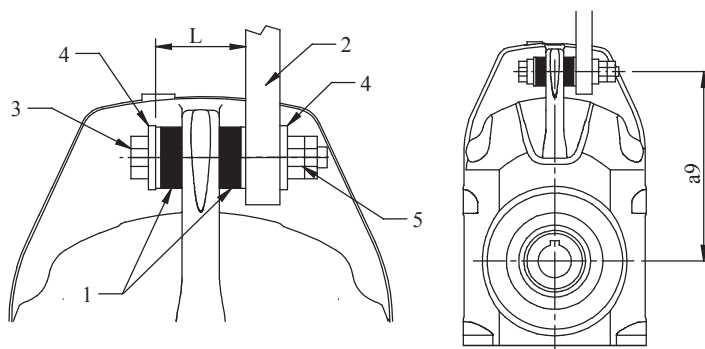

1. Torque arm components consist of a pair of rubber buffers (1) the customer must supply other components.
2. The gear unit should be anchored to a plate (2) using a bolt (3), washers (4), nut and locknut (5) as shown above.
3. Tighten bolt (3) to compress rubber bushes (1) to achieve dimension 'L' (listed in table below) secure with locknut.

Unit	L	Bolt (3)	a9	Unit	L	Bolt (3)	a9	Unit	L	Bolt (3)	a9
F02	2.00	M12 (7/16")	5.51	F05	2.00	M12 (7/16")	7.8	F08	3.31	M20 (3/4")	13.62
F03			6.22	F06			8.58	F09			15.55
F04			6.69	F07			10.95	F10			19.09

Dimensions (inches)

Series K Torque Bracket

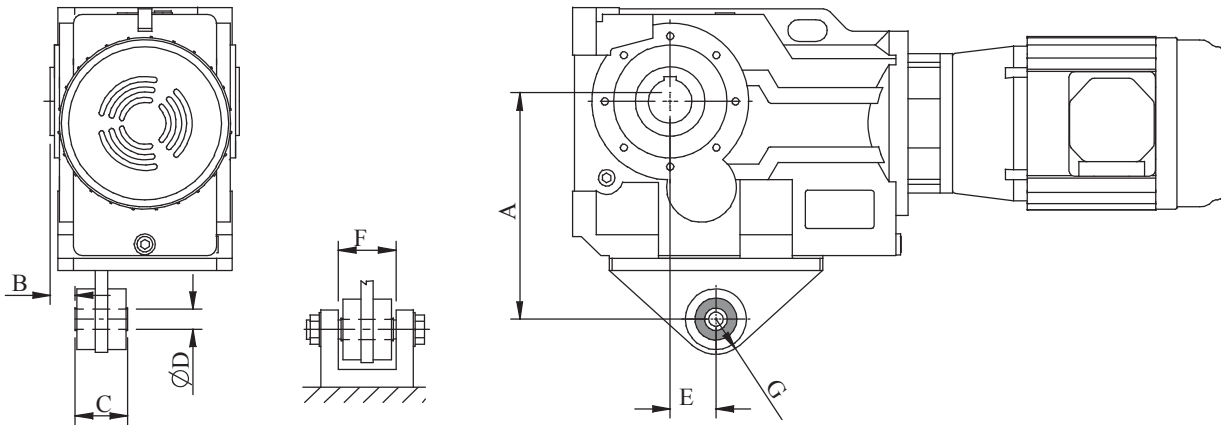

1. It is recommended that the torque bracket is positioned on the side of the gear unit adjacent to the driven machine.
2. The torque bracket requires a clevis type anchoring as shown above (not supplied)
3. The clevis position should be carefully adjusted at assembly so that it does not exert any external radial or axial pressure on the torque bracket

Torque Bracket Dimensions (Inches)

Unit	A	B	C	D	E	F (min)	G
K03	5.51	0.79	1.42	0.41	0.93	1.61	0.91
K04	6.30	0.79	1.42	0.41	1.18	1.61	0.91
K05	7.56	0.71	2.36	0.65	1.57	2.56	1.50
K06	7.87	0.98	2.36	0.65	1.77	2.56	1.50
K07	9.84	0.98	2.36	0.65	2.07	2.56	1.50
K08	11.81	1.18	3.15	0.98	2.36	3.35	1.77
K09	13.78	1.57	3.94	0.98	2.76	4.13	1.77
K10	17.72	1.77	3.94	0.98	2.91	4.13	1.77
K12	21.65	0.39	4.96	1.50	2.36	5.16	2.48



Three Phase Induction Motor Installation.

Connection to Mains Power Supply.

- Connection of the electric motor to the mains supply should be done by a qualified person.
- Connect motor terminals in accordance with the diagram inside the terminal box cover. (Also identified in the diagram below - this instruction only applies to our own brand plated motors)
- Motors fitted by the customer or requested by the customer from a different manufacturer will have separate documentation provided with it.

Note: It is important that the mains supply details are checked against the motor nameplate data and that they are connected as indicated on the nameplate. The correct sizing of the cables to electrical regulations is essential.

- To change the direction of rotation of the electric motor, one of the three main line terminals should be changed with the other.

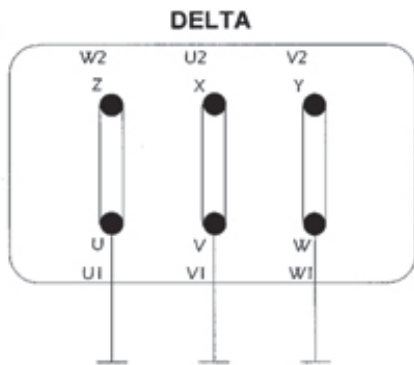

≤ 3.0 HP	220 / 240 v, 50Hz
	230 / 280 V, 60 Hz
≥ 4 HP	380 / 420 V, 50 Hz
	440 / 480 V, 60 Hz

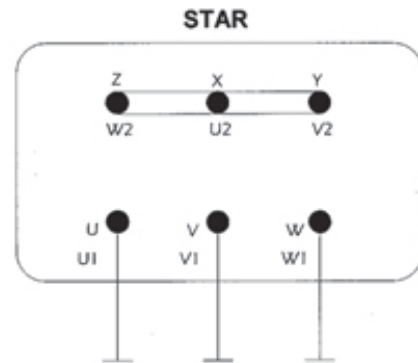

≤ 3.0 HP	380 / 420 V, 50 Hz
	440 / 480 V, 60 Hz
≥ 4 HP	660 / 690 V, 50 Hz

Approved Lubrication.

Type E Mineral oil containing industrial EP additives.

SUPPLIER	LUBRICANT TYPE	5E	6E	7E
Batoyle Freedom Group	Remus	220 (-2)	320 (-2)	460 (-2)
Boxer Services / Millers Oils	Indus	220 (-10)	320 (-10)	460 (-10)
BP Oil International Limited	Energol GR-XF	220 (-16)	320 (-13)	460 (-1)
	Energol GR-XP	220 (-15)	320 (-10)	460 (-7)
Caltex	Meropa	220 (-4)	320 (-4)	460 (-4)
	RPM Borate EP Lubricant	220 (-7)	320 (-4)	460 (-7)
Carl Bechem GmbH	Berugear GS BM	220 (-20)	320 (-13)	460 (-10)
	Staroil G	220 (-13)	320 (-13)	460 (-10)
Castrol International	Alpha Max	220 (-19)	320 (-13)	460 (-10)
	Alpha SP	220 (-16)	320 (-16)	460 (-1)
Chevron International Oil Company Limited	Gear Comp EP (USA ver)	220 (-16)	320 (-13)	460 (-10)
	Gear Comp EP (Eastern ver)	220 (-13)	320 (-13)	460 (-13)
	Ultra Gear	220 (-10)	320 (-7)	460 (-7)
Eko-Elda Abee	Eko Gearlub	220 (-13)	320 (-10)	460 (-1)
Engen Petroleum Limited	Gengear	220 (-15)	320 (-12)	460 (-3)
Esso/Exxon	Spartan EP	220 (-12)	320 (-12)	460 (-4)
Fuchs Lubricants	Powergear		P/Gear (-16)	M460 (-4)
	Renogear V	220EP (-13)	320EP (-4)	460EP (-4)
	Renogear WE	220 (-7)	320 (-4)	400 (-4)
	Renolin CLPF Super	6 (-13)	8 (-10)	10 (-10)
Klüber Lubrication	Klüberoil GEM1	220 (-5)	320 (-5)	460 (-5)
Kuwait Petroleum International	Q8 Goya	220 (-16)	320 (-13)	460 (-10)
Lubrication Engineers Inc.	Almasol Vari-Purpose Gear	607 (-18)	605 (-13)	608 (-10)
Mobil Oil Company Limited	Mobil gear 600 series	630 (-13)	632 (-13)	634 (-1)
	Mobil gear XMP	220 (-19)	320 (-13)	460 (-7)
Omega Manufacturing Division	Omega 690		85w/140 (-15)	
Optimal Ölwerke GmbH	Optigear BM	220 (-11)	320 (-10)	460 (-7)
	Optigear	220 (-18)	320 (-9)	460 (-7)
Pertamina (Indonesia)	Masri	220 (-4)	320 (-4)	460 (-7)
Petro-Canada	Ultima EP	220 (-22)	320 (-16)	460 (-10)
Rocol	Sapphire Hi-Torque	220 (-13)	320 (-13)	460 (-13)
Sasol Oil (Pty) Limited	Cobalt	220 (-4)	320 (-1)	460 (-4)
	Hemat	220 (-10)	320 (-7)	460 (-4)
Saudi Arabian Lubr. Oil Co.	Gear Lube EP	EP220 (-1)	EP320 (0)	EP460 (0)
Shell Oils	Omala	220 (-4)	320 (-4)	460 (-4)
	Omala F	220 (-13)	320 (-10)	460 (-4)
Texaco Limited	Meropa	220 (-16)	320 (-16)	460 (-10)
	Meropa WM	220 (-19)	320 (-16)	460 (-11)
Total	Carter EP	220 (-21)	320 (-15)	460 (-12)
	Carter XEP	220 (-24)	320 (-18)	460 (-13)
Tribol GmbH	Molub-Alloy Gear Oil	90 (-18)	690 (-16)	140 (-13)
	Tribol 1100	220 (-20)	320 (-18)	460 (-16)

DANGER: Numbers in brackets indicate the minimum pour point temperature of the specified oil in °C

THE UNIT MUST NOT BE RUN BELOW THIS TEMPERATURE

Approved Lubrication – Series C

Type G Polyglycol based synthetic lubricants with Anti-Wear or EP additives.

SUPPLIER	LUBRICANT TYPE	5G	6G	7G	8G	9G
Boxer Services / Millers Oils	Boxergear W	220 (-31)	320 (-31)	460 (-28)		
BP Oil International Limited	Enersyn SG-XP	220 (-31)	320 (-31)	460 (-34)	680 (-28)	
Caltex	Synlube CLP	220 (-34)	320 (-31)	460 (-28)	680 (-31)	
Carl Bechem GmbH	Berusrsynth EP	220 (-25)	320 (-25)	460 (-25)	680 (-28)	1000 (-28)
Castrol International	Alphasyn PG	220 (-34)	320 (-31)	460 (-28)		
Esso/Exxon	Glycolube	220 (-25)	320 (-25)	460 (-23)		
Fuchs Lubricants	Renolin PG	220 (-34)	320 (-34)	460 (-34)	680 (-28)	1000 (-28)
Klüber Lubrication	Klübersynth GH6	220 (-25)	320 (-25)	460 (-20)	680 (-20)	1000 (-28)
	Klübersynth UH1 6	220 (-30)	320 (-25)	460 (-25)		
Kuwait Petroleum International	Q8 Gade	220 (-22)	320 (-22)	460 (-22)		
Laporte Performance Chemicals Limited	Berox Industrial Lubricant SW	220 (-25)	320 (-25)	460 (-23)	680 (-20)	1000 (-28)
	Berox SL Range	220 (-40)	320 (-37)	460 (-23)		
	Berox Oil Soluble Industrial Lube x	220 (-23)				
Mobil Oil Company Limited	Glygoyle	HE220 (-22)	HE320 (-37)	HE460 (-35)		
Optimal Ölwerke GmbH	Optiflex A +	220 (-28)	320 (-28)	460 (-28)	680 (-28)	1000 (-25)
Shell Oils	Tivela	SB (-25)	SC (-25)	SD (-23)		
	Tivela S	220 (-34)	320 (-34)	460 (-34)		
Texaco Limited	Synlube CLP	220 (-34)	320 (-31)	460 (-10)	680 (-31)	
Total	Carter SY	220 (-25)	320 (-28)	460 (-22)		
Tribol GmbH	Tribol 800	220 (-27)	320 (-25)	460 (-25)	680 (-25)	1000 (-23)

- + NOT SUITABLE FOR APPLICATIONS REQUIRING INDUSTRIAL EP ADDITIVES
 x THIS PARTICULAR LUBRICANT IS COMPATIBLE WITH TYPES E, AND H

DANGER: Numbers in brackets indicate the minimum pour point temperature of the specified oil in °C

THE UNIT MUST NOT BE RUN BELOW THIS TEMPERATURE

Approved Lubrication.

Type H Polyalphaolefin based synthetic lubricants with Anti-Wear or EP additives.

SUPPLIER	LUBRICANT TYPE	5H	6H
Batoye Freedom Group	Titan	220 (-31)	320 (-28)
Boxer Services / Millers Oils	Silkgear	220 (-35)	320 (-35)
BP Oil International Limited	Energyn EPX	-	320 (-28)
Caltex	Pinnacle EP	220 (-43)	320 (-43)
Carl Bechem GmbH	Berusynth GP	220 (-38)	320 (-35)
Castrol International	Alphasyn EP	220 (-37)	320 (-31)
	Alphasyn T	220 (-31)	320 (-28)
Chevron International Oil Co	Tegra	220 (-46)	320 (-33)
Esso/Exxon	Spartan Synthetic EP	220 (-46)	320 (-43)
Fuchs Lubricants	Renogear SG	220 (-32)	320 (-30)
	Renolin Unisyn CLP	220 (-37)	320 (-34)
Klüber Lubrication	Klübersynth GEM4	220 (-30)	320 (-25)
Kuwait Petroleum International	Q8 El Greco	220 (-22)	320 (-19)
Lubrication Engineers Inc.	Synolec Gear Lubricant	220 (-40)	-
Mobil Oil Company Limited	Mobilgear SHC	220 (-40)	320 (-37)
	Mobil gear XMP	220 (-40)	320 (-33)
Optimal Ölwerke GmbH	Optigear Synthetic A	220 (-31)	320 (-31)
Petro-Canada	Super Gear Fluid	220 (-43)	320 (-37)
Shell Oils	Omala HD	220 (-43)	320 (-40)
Texaco Limited	Pinnacle EP	220 (-43)	320 (-43)
	Pinnacle WM	220 (-43)	320 (-40)
Total	Carter SH	220 (-45)	320 (-42)
Tribol GmbH	Tribol 1510	220 (-36)	320 (-33)

DANGER: Numbers in brackets indicate the minimum pour point temperature of the specified oil in °C

THE UNIT MUST NOT BE RUN BELOW THIS TEMPERATURE

Approved Grease

NLGI grade 2 grease suitable for operation in ambient temperatures of -20°C to 50°C (-4°F to 150°F)
 - For use outside of this range contact our Application Engineers

SUPPLIER	GREASE TYPE
BP Oil International Limited	Energrease LS-EP
Caltex	Mulfak EP
Castrol International	LMX Grease
	Spheerol AP
	Spheerol EPL
Fuchs Lubricants	Renolit EP
Klüber Lubrication	Klüberlub BE41-542
Mobil Oil Company Limited	Mobilgrease XHP
	Mobilith SHC
Omega	Omega 85
Optimol	Longtime PD
Shell Oils	Albida RL
	Alvania EP B
	Nerita HV
Texaco Limited	Mulfak EP

Series C Lubrication

1. C03 to C06 are supplied factory filled with a quantity of polyglycol synthetic oil (Grade 6G) appropriate to the mounting position – If the gear unit is drained for any reason it must be re-filled with the correct grade and quantity of lubricant as shown in the table below.
2. C07 to C10 are supplied without lubricant and must be filled via the ventilator position with polyglycol synthetic oil (Grade 6G) until the oil escapes through the level plug hole – see table below for approximate lubricant quantity,
3. C07 to C10 Oil levels for some units are dependent on mounting position and speed of operation.
 Level 1 (L-1) for output speeds below 100 rpm
 Level 2 (L-2) for output speeds 100 rpm and above
4. **Maintenance:**
 - Oil levels for C07 to C10 can be checked and maintained by filling via the ventilator position until oil escapes through the level plug hole,
 - C03 to C06 these units must be fully drained and re-filled with the correct quantity of lubricant

Lubricant Quantities (Gallons US)

Posn	Level	C0321	C0421	C0521	C0621	C0721	C0821	C0921	C1021
1	L-1	0.08	0.11	0.18	0.40	1.19	1.88	4.49	7.40
	L-2	-	-	-	-	0.79	1.56	2.91	4.49
2	-	0.13	0.18	0.26	0.61	0.92	1.64	3.17	5.55
3	-	0.13	0.18	0.26	0.61	0.92	1.64	3.17	5.55
4	L-1	0.18	0.26	0.37	0.82	1.35	2.51	4.49	6.87
	L-2	-	-	-	-	0.79	1.27	2.19	3.70
5	-	0.16	0.24	0.37	0.79	1.48	2.54	4.76	8.19
6	L-1	0.18	0.26	0.37	0.85	1.96	3.17	6.61	11.10
	L-2	-	-	-	-	1.35	2.51	4.49	7.40

Posn	Level	C0331	C0431	C0531	C0631	C0731
1	L-1	0.11	0.13	0.24	0.55	1.27
	L-2	-	-	-	-	1.00
2	-	0.21	0.24	0.37	0.66	0.98
3	-	0.21	0.24	0.37	0.66	0.98
4	L-1	0.32	0.40	0.55	1.06	1.56
	L-2	-	-	-	-	0.95
5	-	0.26	0.34	0.53	1.22	1.74
6	L-1	0.32	0.40	0.50	1.06	2.43
	L-2	-	-	-	-	1.82

5. C07 to C10 Fit the ventilator plug in the position appropriate to the mounting position. C03 to C06 do **not** require a ventilator
6. Quadruple Reduction Units consist of a Series M primary unit flange mounted onto the Series C unit, see Series M lubrication data for details appropriate to the primary unit, both units should be checked for oil type and quantity.

Series C Mounting Positions and Lubrication fill levels

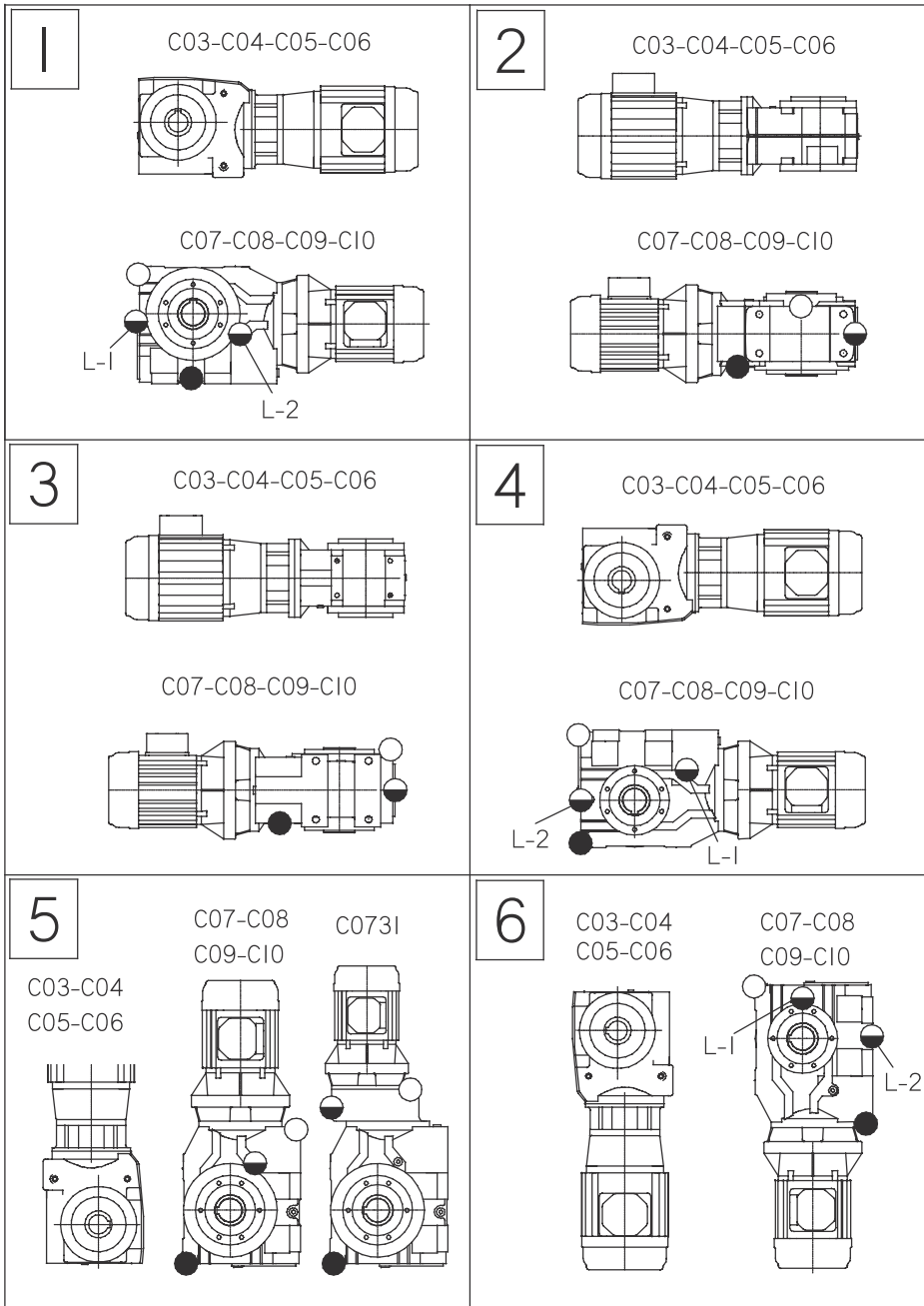

Series F Lubrication

1. F02 to F07 are supplied factory filled with a quantity of EP mineral oil (Grade 6E) appropriate to the mounting position. If the gear unit is drained for any reason it must be re-filled with the correct grade and quantity of lubricant as shown in the table below.
2. F08 to F10 are supplied without lubricant and must be filled via the ventilator position with EP mineral oil (Grade 6E) until oil escapes through the level plug hole – see table below for approximate quantity of lubricant.
3. **Maintenance:**
 - Oil levels for F05 to F10 can be checked and maintained by filling via the ventilator position until oil escapes through the level plug hole,
 - F02, F03 and F04 These units must be fully drained and re-filled with the correct quantity of lubricant.

Lubricant Quantities (Gallons US)

Posn	F0222	F0322	F0422	F0522	F0622	F0722	F0822	F0921	F1021
1	0.21	0.34	0.34	0.55	0.92	1.66	2.83	5.02	8.98
2	0.11	0.21	0.21	0.37	0.61	0.92	1.88	3.43	5.81
3	0.11	0.29	0.29	0.37	0.61	0.90	2.32	4.49	7.40
4	0.13	0.21	0.21	0.48	0.79	1.32	1.24	3.96	7.13
5	0.29	0.32	0.32	0.74	1.19	2.11	2.56	6.34	11.36
6	0.34	0.53	0.53	0.85	1.37	2.38	4.54	6.61	11.36

Posn	F0232	F0332	F0432	F0532	F0632	F0732	F0832	F0931	F1031
1	0.21	0.32	0.32	0.55	0.92	1.66	2.75	5.02	8.98
2	0.11	0.21	0.21	0.37	0.61	0.92	1.93	3.96	6.34
3	0.11	0.29	0.29	0.37	0.61	0.90	2.43	4.49	7.40
4	0.13	0.21	0.21	0.48	0.79	1.32	1.40	4.23	7.13
5	0.29	0.32	0.32	0.74	1.19	2.11	2.56	6.34	11.36
6	0.34	0.53	0.53	0.85	1.37	2.38	4.60	6.61	11.36

4. F09 to F10 units only, fit the ventilator plug in the position appropriate to the mounting position. F02 to F08 units do **not** require a ventilator
5. Quadruple Reduction Units consist of a Series M primary unit flange mounted onto the Series F unit, see Series M lubrication data for details appropriate to the primary unit, both units should be checked for oil type and quantity.

Series F - Mounting Positions and Lubrication Fill Levels

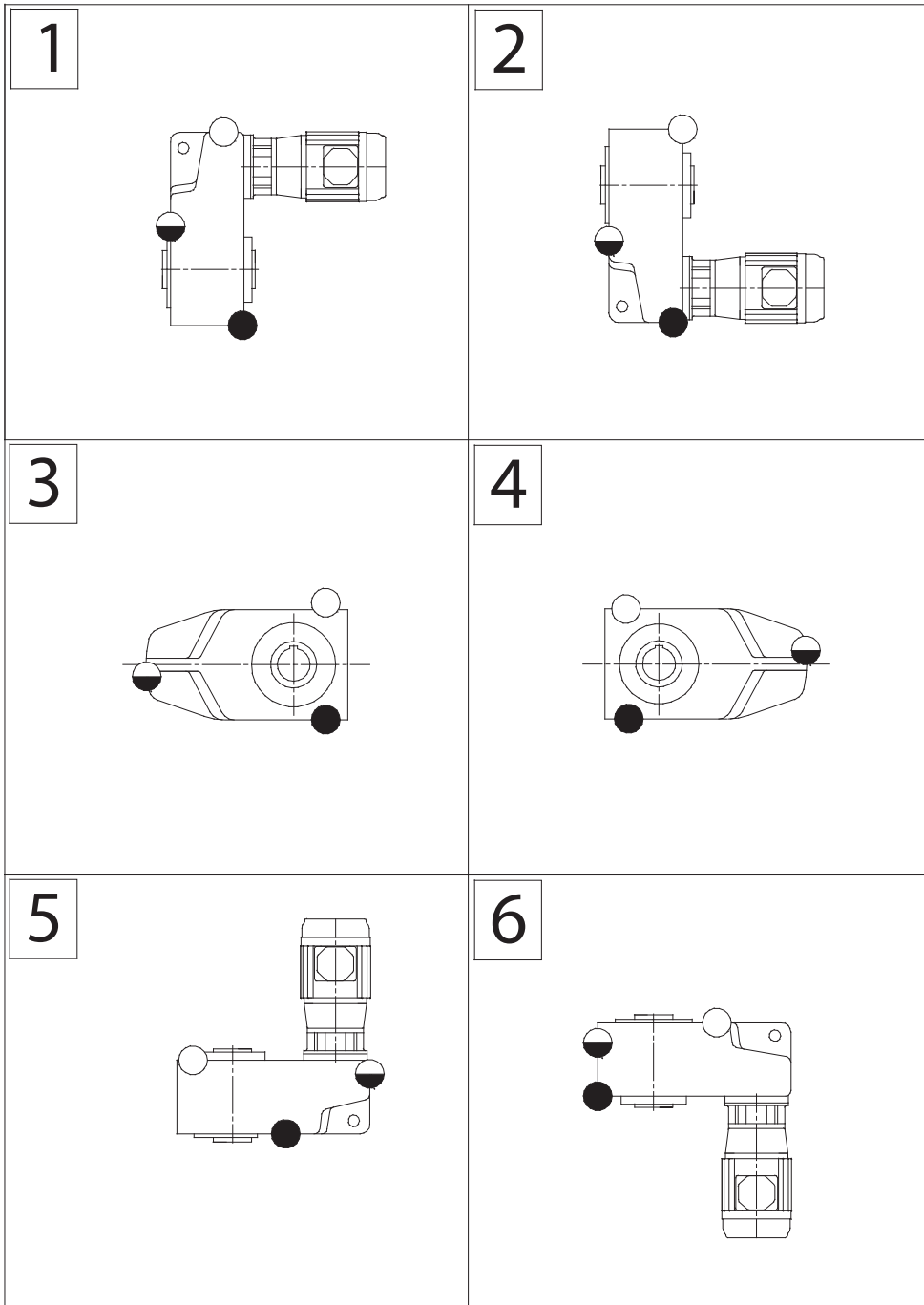

Series K Lubrication

1. K03 to K07 are supplied factory filled with a quantity of EP mineral oil (Grade 6E) appropriate to the mounting position – If the gear unit is drained for any reason it must be re-filled with the correct grade and quantity of lubricant as shown in the table below.
2. K08 to K12 are supplied without lubricant and must be filled via the ventilator position with EP mineral oil (Grade 6E) until oil escapes through the level plug hole – see table below for approximate lubricant quantity,
3. **Maintenance:**
 - Oil levels for K06 to K12 can be checked and maintained by filling via the ventilator position until oil escapes through the level plug hole,
 - K03, K04 and K05 These units must be fully drained and re-filled with the correct quantity of lubricant.

Lubricant Quantities: (Gallons US)

Posn	K0332	K0432	K0532	K0632	K0732	K0832	K0931	K1031	K1231
1	0.13	0.18	0.29	0.40	0.71	1.16	2.46	3.96	6.08
2	0.18	0.24	0.40	0.48	0.95	0.98	2.19	3.96	7.13
3	0.21	0.29	0.45	0.74	1.06	2.01	4.76	7.40	8.72
4	0.26	0.34	0.50	0.71	1.19	1.98	4.49	7.93	10.30
5	0.32	0.45	0.66	0.95	1.51	2.54	5.55	8.98	13.21
6	0.24	0.32	0.53	0.69	1.19	2.01	4.23	6.61	9.25

4. K06 to K12 units only, fit the ventilator plug in the position appropriate to the mounting position. K03 to K05 units do **not** require a ventilator.
5. Quintuple Reduction Units consist of a Series M primary unit flange mounted onto the Series K unit, see Series M lubrication data for details appropriate to the primary unit, both units should be checked for oil type and quantity.

Series K - Mounting Positions and Lubrication Fill Levels

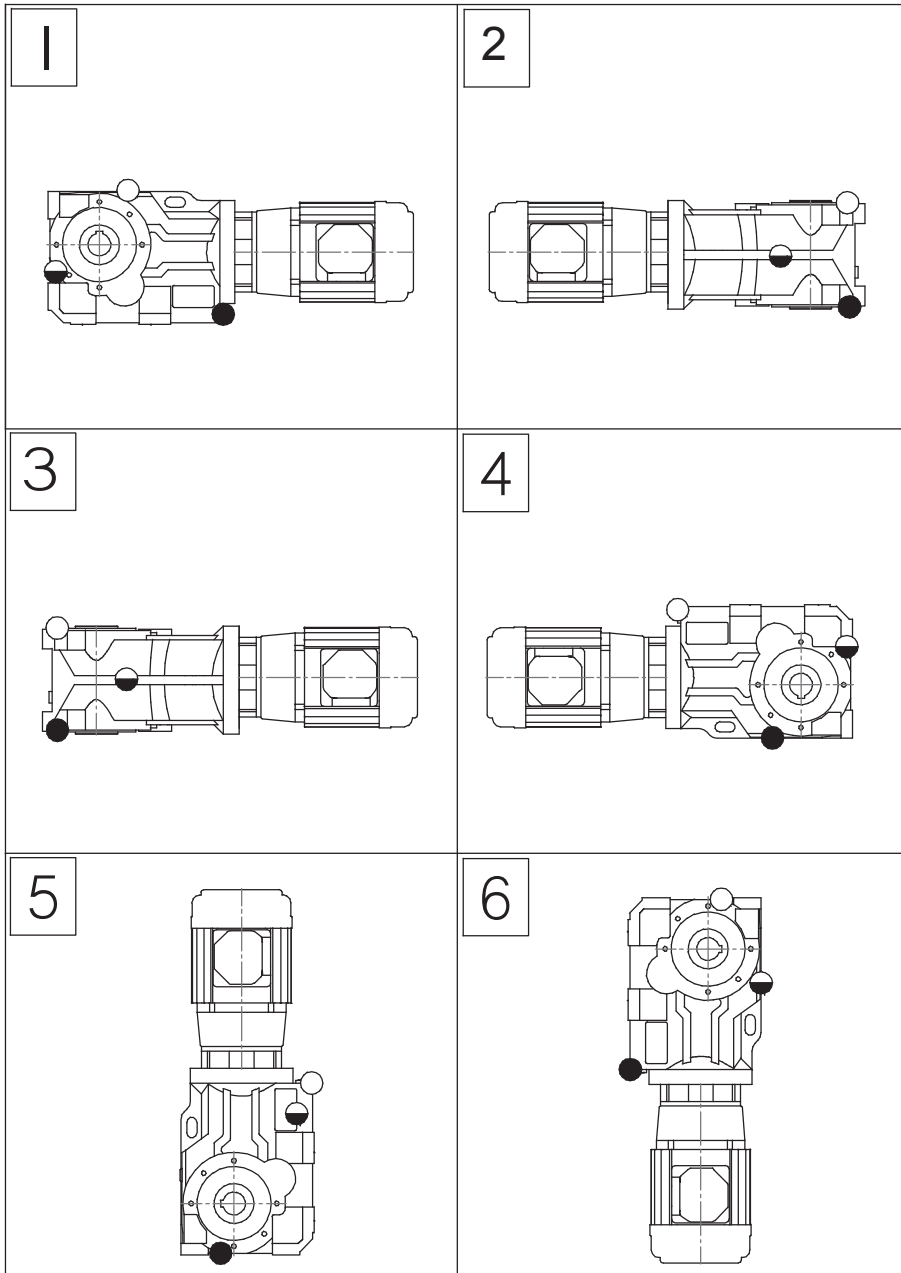

Series M Lubrication

1. M01 to M07 are supplied factory filled with a quantity of EP mineral oil (Grade 6E) appropriate to the mounting position – If the gear unit is drained for any reason it must be re-filled with the correct grade and quantity of lubricant as shown in the table below.
2. M08 to M14 are supplied without lubricant and must be filled via the ventilator position with EP mineral oil (Grade 6E) until oil escapes through the level plug hole – see table below for approximate lubricant quantity,
3. **Maintenance:**
 - Oil levels for M04 to M14 can be checked and maintained by filling via the ventilator position until oil escapes through the level plug hole,
 - These units M01, M02 and M03 must be fully drained and re-filled with the correct quantity of lubricant.

Lubricant Quantities: (Gallons US)

Posn	M0122	M0222	M0322	M0422	M0522	M0622	M0722	M0822	M0921	M1021	M1321	M1421
1	0.13	0.21	0.21	0.40	0.40	0.53	0.69	1.11	2.77	3.70	4.49	6.34
2	0.21	0.32	0.32	0.48	0.48	0.53	0.77	1.66	3.17	5.81	8.19	12.95
3	0.16	0.18	0.18	0.42	0.42	0.50	0.71	1.43	3.17	5.81	8.19	12.95
4	0.21	0.32	0.32	0.48	0.48	0.45	0.79	1.93	3.17	5.02	7.40	10.83
5	0.18	0.29	0.29	0.53	0.53	0.58	0.85	1.80	4.44	8.45	12.42	19.02
6	0.26	0.37	0.37	0.69	0.69	0.74	1.24	2.46	4.33	6.87	10.04	17.17

Posn	M0132	M0232	M0332	M0432	M0532	M0632	M0732	M0832	M0931	M1031	M1331	M1431
1	0.16	0.21	0.21	0.42	0.42	0.55	0.71	1.16	3.04	3.70	4.76	6.61
2	0.24	0.34	0.34	0.50	0.50	0.55	0.79	1.72	3.17	6.34	8.72	13.21
3	0.18	0.18	0.18	0.45	0.45	0.53	0.74	1.48	3.17	6.34	8.72	13.21
4	0.24	0.32	0.32	0.50	0.50	0.48	0.82	1.98	3.17	5.55	7.93	11.36
5	0.18	0.29	0.29	0.55	0.55	0.61	0.87	1.80	4.44	8.45	12.42	19.02
6	0.29	0.42	0.42	0.71	0.71	0.77	1.27	2.56	4.36	7.40	10.57	17.70

6. M04 to M14 units only, fit the ventilator plug in the position appropriate to the mounting position. M01 to M03 units do **not** require a ventilator.
7. Quintuple Reduction Units consist of a smaller Series M primary unit flange mounted onto the main Series M gear unit, both units should be checked for oil type and quantity.

Series M - Mounting Positions and Lubrication Fill Levels

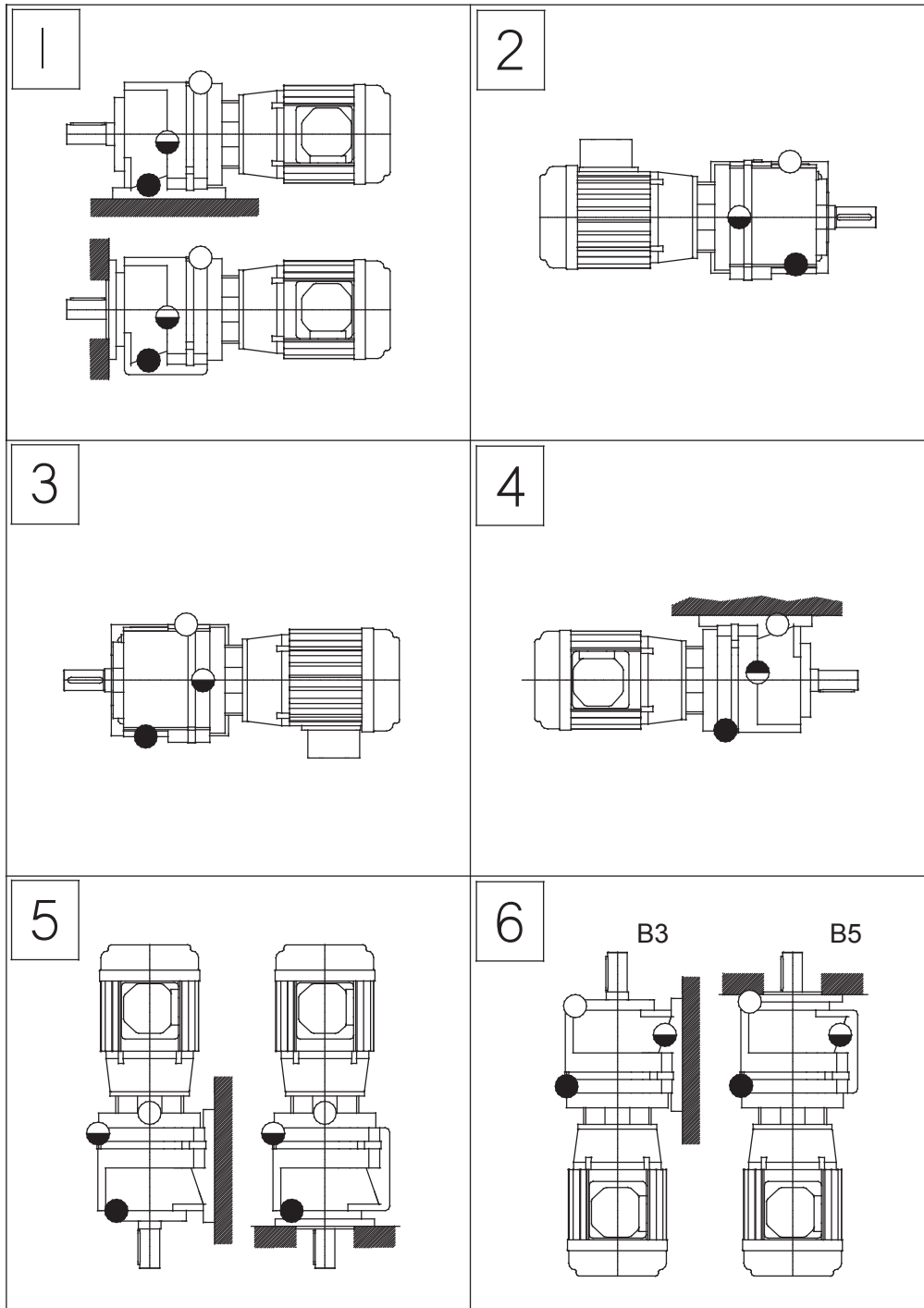

-  Drain Position
-  Level Position
-  Ventilator Position